

# Product Guide



Ignition  
Systems

Spark Plugs  
& Accessories

Gas Engine  
Control Systems

Sensor  
Systems

Air/Fuel Ratio  
Control Systems

Gas Engine  
Accessories

## GAS ENGINE TECHNOLOGY

reliable • efficient • worldwide

# Table of Contents

## 4 ■ Ignition Controllers & Harnesses

- 4 Characteristics MIC Series
- 5 Technical Data
- 6 MOST –  
MOTORTECH Output Stage Technology
- 7 MICT –  
MOTORTECH Integrated Configuration Tool
- 8 System Overview MIC3+/MIC4/MIC5
- 10 MIC3+ Series
- 12 MIC4 Series
- 14 MIC4-ZS Kits
- 15 MIC5 Series
- 17 MIC6 Series
- 22 PowerView3 – Ignition Control Visualization
- 24 MOT601 Single Cylinder Ignition System
- 26 Harnesses for Competition  
Ignition Control Systems

## 28 ■ Ignition Coils

- 28 New MOTORTECH Style
- 29 MOTORTECH Style
- 29 ALTRONIC® Style
- 30 Ignition Coils for CATERPILLAR® Gas Engines
- 32 Ignition Coil for WÄRTSILÄ® Gas Engines
- 33 Ignition Coil Conversion Kits  
for Cummins® Gas Engines
- 34 Ignition Coil Extensions
- 36 Accessories for Unshielded Ignition Coils
- 38 Flange Ignition Coils
- 42 Hardware Kit for WAUKESHA® VHP-GL Engines
- 44 Externally Mounted Ignition Coils
- 46 Integral Ignition Coils

## 50 ■ Pickups & Trigger Drives

- 50 Pickups
- 52 Special Application Pickups
- 53 Pickup Leads
- 54 Trigger Discs
- 56 Trigger Pins & Magnets
- 56 Trigger Drives
- 58 Trigger Devices
- 60 Tools & Accessories

## 62 ■ Primary Leads

- 62 Primary Leads – New Flex Style
- 65 Special Application Primary Leads
- 66 Primary Leads for AlphaRail Wiring Rails

## 68 ■ Spark Plug Leads & Extensions

- 68 Spark Plug Leads – Patented PolyMot™ Style
- 73 Spark Plug Leads for CATERPILLAR® Gas Engines
- 74 Spark Plug Leads – for common Applications  
(Non PolyMot™ Style)
- 75 Unshielded Safety Leads  
for Shielded Spark Plugs
- 78 Accessories for Unshielded Spark Plug Leads
- 82 MOT-Blues Shielded Spark Plug Leads
- 84 Conventional Shielded Spark Plug Leads
- 85 Terminal Repair Kits
- 86 Spark Plug Extensions –  
Patented PolyMot™ Style
- 88 Ignition Coil Extensions
- 89 Ignition Coil Extension Overhaul Kits
- 91 Extensions for Integral Ignition Coils
- 91 Extensions for Shielded Spark Plugs

## 94 ■ Ignition Wiring Rails & Hardware

- 94 Wiring Rail System for Ignition Control
- 100 Ignition Wiring Rail Upgrade Kits
- 102 Ignition Wiring Rail Kits for  
CATERPILLAR® Gas Engines
- 105 Ignition Kits for Unshielded Applications

## 110 ■ Ignition Tools & Test Equipment

- 110 SparkView High Voltage Indicator
- 111 SparkScan1 High Voltage Clamp
- 111 Digital Scope Meter
- 112 Ignition Coil Tester
- 113 IPS Ignition Pickup Simulator
- 114 Test Adaptor for MIC3/3+, MIC4 and  
MIC5 Series Ignition Controller
- 115 ScopeLite Timing Light
- 116 Tools & Workshop Equipment

# Table of Contents

## 120 ■ Spark Plugs & Accessories

- 120 DENSO® Spark Plugs
- 123 MOTORTECH High Performance Spark Plugs
- 124 XT-Plugs – Extended Barrel Spark Plugs
- 126 XTL-Plugs – Extended Barrel Spark Plugs
- 130 ICP Spark Plugs with Dual Thread
- 131 Spark Plug Cleaning Kit
- 132 Spark Plug Tools
- 136 Spark Plug Accessories

## 138 ■ Gas Engine Control Systems

- 138 DetConzo Detonation Control System
- 141 PowerView3 Detonation Control Visualization
- 142 AlphaRail Wiring Rail System for Detonation Control
- 146 TempScanzo Temperature Module
- 147 PowerView3 Temperature Scanner Visualization
- 148 AlphaRail Wiring Rail System for Temperature Control
- 152 Throttle Bodies with Integrated Stepper Motor
- 154 Throttle Bodies
- 156 Throttle Bodies for MAN® Gas Engines
- 158 Throttle Bodies for WAUKESHA® Gas Engines
- 160 ALL-IN-ONE Generator & CHP Control Systems
- 164 Actuator Replacement Kit for WAUKESHA® VHP Series Engines

## 166 ■ Sensor Systems

- 166 Thermocouple Rails for WAUKESHA® 12 Cylinder VHP Engines
- 168 Thermocouples
- 170 Oxygen Sensors
- 172 MAT – Manifold Air Temperature Sensors
- 172 MAP – Manifold Absolute Pressure Sensor

## 176 ■ Air/Fuel Ratio Control Systems

- 176 VariFuel Air/Gas Mixer Series
- 186 VariStep3 Stepper Motor Driver
- 187 EmCon5 Lean-Burn Emission Controller
- 190 VariSCR NO<sub>x</sub> Emission Controller

## 194 ■ Gas Engine Accessories

- 194 OLC Oil Level Controller
- 198 Coolant Filtration
- 200 Lube Oil Filtration
- 202 Ultrasonic Cleaning Equipment

## 206 ■ Technical Service & Support

## 208 ■ Index

# Ignition Controllers & Harnesses

## Characteristics MIC Series



**MIC3+**  
MOTORTECH IGNITION CONTROLLER



**MIC4**  
MOTORTECH IGNITION CONTROLLER



**MIC5**  
MOTORTECH IGNITION CONTROLLER



**MIC6**  
MOTORTECH IGNITION CONTROLLER

### General

- For 2- and 4-stroke engines
- Ignition technology pulse width modulated
- Technical restriction to 6000 rpm
- Max. trigger impulses 16+1 or 500 teeth on the flywheel

### Technical Data & Features

- Ignition timing to 0.1° crankshaft
- Triggered by magnetic, Hall effect or inductive pickup
- Multiple ignition timing control via
  - Potentiometer (except MIC3+ and MIC6 series)
  - Speed curve
  - 0 to 20 mA analog input
  - 0 to 10 V analog input
- Multiple energy control via MOST (MOTORTECH Output Stage Technology)
- Programmable firing order
- Overspeed shutdown function
- Access controlled
- Programmable spark duration
- Energy output control
- 2 programmable speed curves with max. 8 speed points (speed/ignition timing)
- Diagnostic memory
- System status display
- Error memory

### Ignition Diagnostics

- Runtime data
- Alarm and error messages
- Data logging
- Primary and secondary misfire detection
- Cylinder individual high-voltage calculation (kV)

### Interfaces

- CAN Bus 2.0b interface (CANopen/SAE J1939 protocol)
- RS485 interface (Modbus RTU)
- USB 1.1 interface

### Inputs

- Digital ignition release (start/stop)
- Configurable digital input (GPI)
- Digital input for schedule A/B

### Outputs

- Max. 2 Auxiliary Synchronization Outputs (ASO) which can support a detonation control system (e.g. DetCon) or fuel injection pump controllers (device dependend)
- Max. 3 multipurpose outputs (GPO) (device dependend)
- Go/NoGo output

### Configuration

- Using the graphic user interface MICT (MOTORTECH Integrated Configuration Tool, see page 7)

### Certifications

- CSA (Class I, Division 2, Group C, D; T4)
- ATEX (II 3G Ex uA II B T4 X) – on request
- CE

### Scope of Supply

- Configuration software MICT (MOTORTECH Integrated Configuration Tool)
- USB interlink cable
- Vibration dampers
- Ground strap
- Fastening material
- Operating manual





## Technical Data

Feature		MIC3+ Series	MIC4 Series	MIC5 Series	MIC6 Series
General	Max. number of ignition outputs	12	16	20	24
	Max. number of pickups	2	3	3	6 (2 sets with max. 3 pickups)
	Power supply	10 to 32 VDC	10 to 32 VDC	16.8 to 32 VDC	16.8 to 32 VDC
	Permitted housing surface temperature	-40 °C to + 60 °C -40 °F to +140 °F	-40 °C to + 60 °C (LD) -40 °F to +140 °F (LD)	-40 °C to + 60 °C -40 °F to +140 °F	-40 °C to + 60 °C -40 °F to +140 °F
Output	Max. primary voltage	250 VDC	250 VDC	250 VDC	250 VDC
	Max. ignition energy	300 mJ (500 mJ) boost for start phase	300 mJ (500 mJ) boost for start phase	500 mJ (600 mJ) boost for start phase	1000 mJ (1200 mJ) boost for start phase
	Max. programmable spark duration	100 to 800 µsec	100 to 1000 µsec	100 to 1500 µsec	100 to 1500 µsec
Housing	Available housing versions <sup>1)</sup>	Light Duty (LD)	Panel Mount (PM), Light Duty (LD), Heavy Duty (HD)	Heavy Duty (HD)	Heavy Duty (HD)
	Dimensions (length x width x height)	250 x 240 x 89.5 mm (LD) 9.84 x 9.45 x 3.52 in. (LD)	304 x 240 x 95.5 mm (LD) 11.97 x 9.45 x 3.76 in. (LD)	371 x 240 x 114.5 mm (HD) 14.61 x 9.45 x 4.51 in. (HD)	385 x 240 x 114.5 mm (HD) 15.16 x 9.45 x 4.51 in. (HD)
	Protection class	IP54 (LD)	IP20 (PM), IP54 (LD), IP65 (HD)	IP65 (HD)	IP65 (HD)
	Engine installation	not permitted	not permitted	not permitted	not permitted
	Number of potentiometers for manual timing adjustment	0	2 (continuous)	2 (continuous)	0
	Input connection	MIL, 35 pole, pin (standard)	terminal strip (standard)	terminal strip (standard)	MIL, 35 pole, pin (standard)
	Output connection	MIL, 17 pole, socket	MIL, 17 pole, socket	MIL, 35 pole, socket	MIL, 35 pole, socket
	Number of status LEDs	5	6	6	11

<sup>1)</sup> Consult factory for information on the availability of housing styles.

# Ignition Controllers & Harnesses

## MOST

MOTORTECH OUTPUT STAGE TECHNOLOGY

### Patented Technology for MIC3+/MIC4/MIC5/MIC6\*

Efficiency-enhanced engines, highly compressed mixtures, as well as the use of a great variety of gas types are putting greater demands on the entire ignition system, including:

- reliable ignition even with weak or fluctuating calorific values of the gas
- compliance with the strictest emission regulations
- avoidance of knocking and misfiring
- reduction of maintenance costs through longer spark plug runtimes

\*Patent No.: US 8,893,692 B2

The graphic compares the behavior of a conventional Capacitor Discharge Ignition System (CDI) and Ignition System with MOST

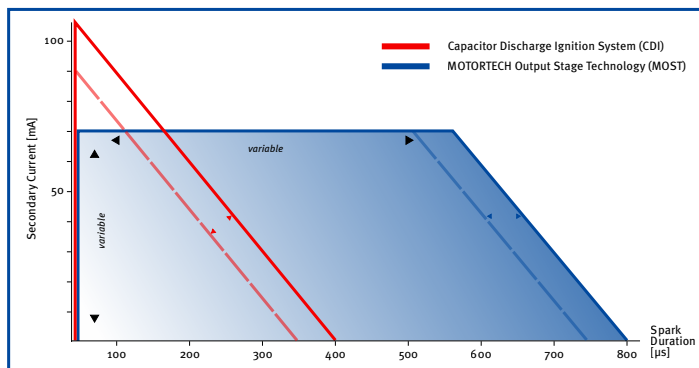

These requirements can only be met by precision ignition behavior and efficient control of the ignition spark. MOTORTECH Output Stage Technology (MOST) was developed by MOTORTECH for this.

MOST works with the following principles:

- adjustable ignition spark duration with different available ignition voltages
- constant spark intensity via adjusted ignition spark duration
- 300 to 1000 mJ of primary energy (device dependent) are available

### Capacitor Discharge Ignition System (CDI)

The red curve shows that a high peak current is reached during ignition. Afterwards, the current decreases sharply. To achieve longer spark duration, the energy supply must be increased. The result of this is a higher peak current.

### Ignition System with MOST

The blue curve shows that a lower peak current is reached during ignition with MOST. The current remains at a constant level until the energy supply ends. Thereafter, the current drops. In this case as well, more energy is supplied for a longer spark duration, however the peak current is not increased in the process.

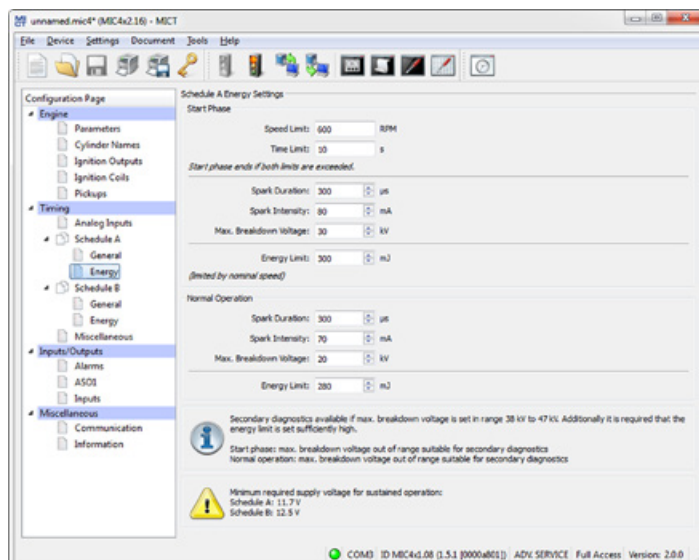

### Settings for MOST in MICT

The settings for MOST are made using the MICT configuration software. On the configuration side *Timing – Schedule A/B – Energy*, you can define different values for the spark duration, spark intensity, breakdown voltage and energy limit for the start phase and normal operation. That way starting difficulties of the engine can be caught. Different energy settings for the two schedules A and B support, for example, optimally matched two gas operation. The settings are dependent on the ignition coils that are used, among other things. They must be suitable for MOST and set correctly on the configuration side *Engine – Ignition Coils*. To optimize the energy settings for an engine, the ignition behavior must be observed and analyzed (misfiring, knock behavior, emission values, etc.). The secondary side diagnostics with MICT, among other things, can help here.

## MICT

MOTORTECH INTEGRATED CONFIGURATION TOOL

The MICT is the graphical user interface for all controllers of the MIC3+, MIC4, MIC5 and MIC6 series. With a laptop all configurations can be done and runtime data of the engine can be checked and adjusted.

- Language selectable (German/English/Chinese)
- Microsoft® Windows XP/Vista/7 compatible
- Included data base offers engine information such as firing order, firing sequence, number of ignition coils per cylinder and typical number of teeth on flywheel for easy engine configuration
- Print function of a given moment in the operation can be used for external problem analysis, etc.
- Context sensitive online help
- Different access levels to avoid accidental misconfigurations

### Sample Screens – Runtime Data



**Overview**  
In the overview schedule the most important current runtime data such as speed, ignition timing or system status can be registered at a glance.

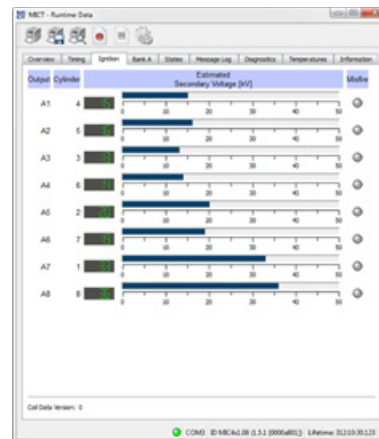

**Breakdown Voltage**  
The MICT offers a lot of real time and detailed information about the status of each individual ignition output. Important data will be visually prepared, so that any irregularities will stand out easily. For example, secondary voltage will be displayed as bar graph, and the type of misfiring carries a warning light as symbol.

### Sample Screens – Parameter Set

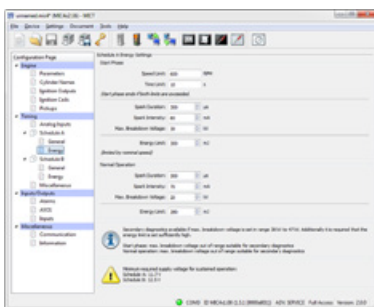

**Energy Settings**  
For start phase and normal operation of the engine, durations at different high voltage levels and ignition spark intensity can be adjusted with the advanced energy settings.

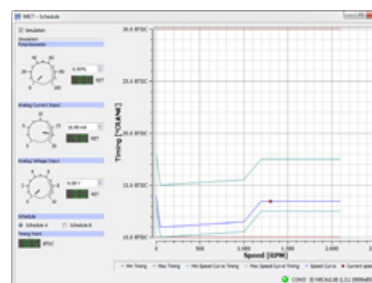

**Configuration Visualisation**  
The graphic display of the parameter set A and B offers a fast, visual control of the configured values.

# Ignition Controllers & Harnesses

## System Overview MIC3+/MIC4/MIC5

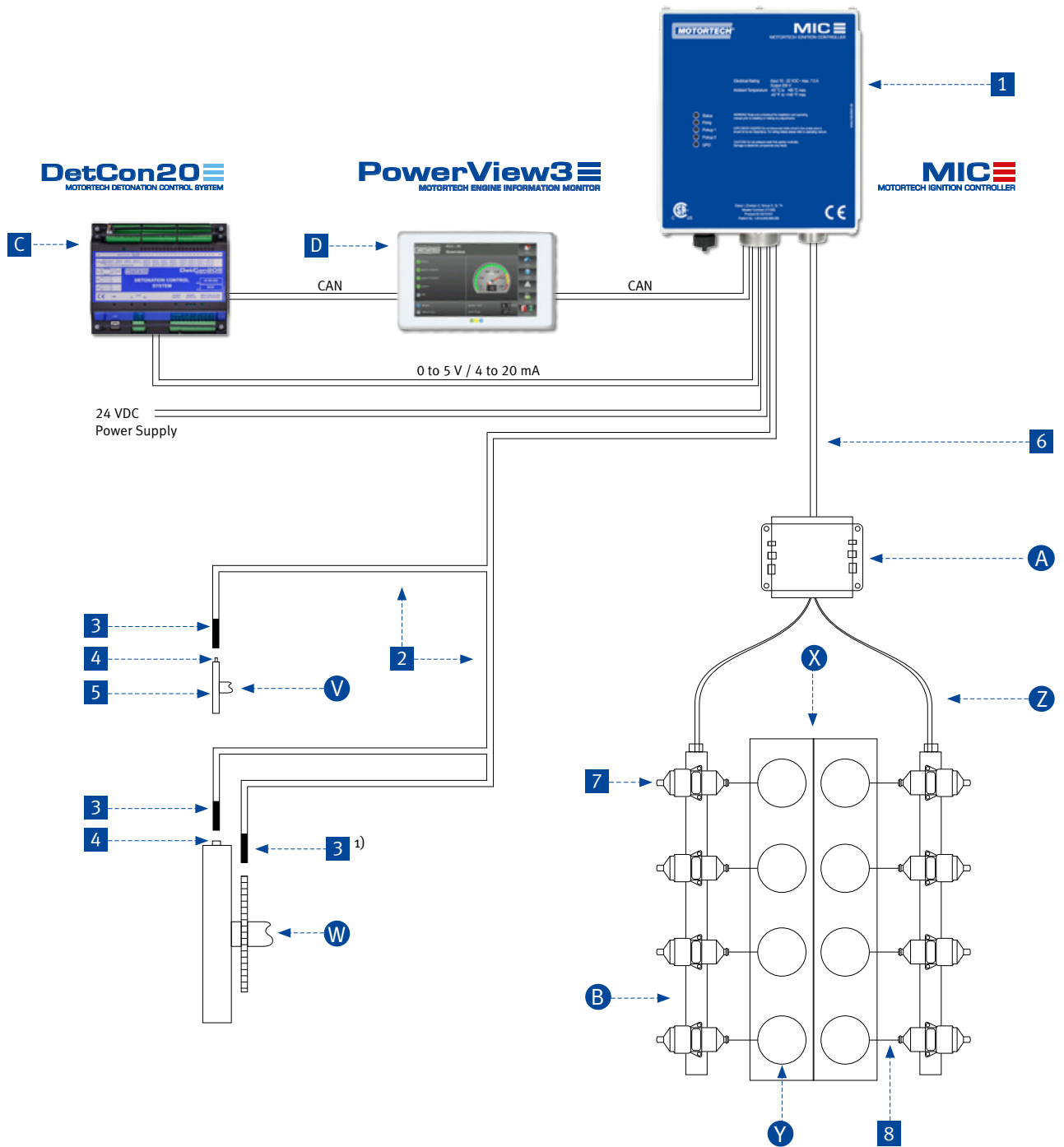

<sup>1)</sup> In combination with the MIC3+ series only one crankshaft pickup possible

## Legend

### Necessary Components

- 1 MIC ignition controller
- 2 Pickup lead\*
- 3 Pickup\*
- 4 Trigger pins/magnets

*alternative*

- 5 Trigger disc

*alternative*

Trigger drive

- 6 Output harness\*
- 7 Ignition coil\*
- 8 1 Primary lead/spark plug lead per ignition coil\*

\* Shielded and unshielded versions available.

### Accessories

- A Junction box
- B AlphaRail-/ LiteRail – ignition wiring rail

### System Enhancement

- C DetCon20 – Detonation controller
- D PowerView3 – HMI module

### Description

- V Camshaft
- W Crankshaft
- X Engine
- Y Cylinder
- Z Harness to connect the ignition wiring rails and the junction box

## Established Pickup Arrangements

### 3-Pickup Arrangement for 4-Stroke Engines

- 1) Crankshaft (Reset)  
Magnetic pickup  
(holes, pins, teeth, screws)
- 2) Crankshaft (Speed)  
Magnetic pickup  
(holes, pins, teeth, screws)
- 3) Camshaft (Reset)  
Hall effect pickup  
(magnets)

*alternative*

- 3) Camshaft (Reset)  
Inductive pickup  
(pins, screws, slots)

### 1-Pickup Arrangement for 4-Stroke Engines

- 1) Camshaft (N+1/N-1)  
Hall effect pickup  
(disc with magnets)
- alternative*
- 1) Camshaft (N+1/N-1)  
Inductive pickup  
(disc with pins, screws, slots)

### 2-Pickup Arrangement for 2-Stroke Engines

- 1) Crankshaft (Reset)  
Magnetic pickup  
(holes, pins, teeth, screws)
- 2) Crankshaft (Speed)  
Magnetic pickup  
(holes, pins, teeth, screws)

# Ignition Controllers & Harnesses



## Ignition Controllers – Light Duty – Standard

P/N	max. Outputs	Connector Style	Connectors		Pickup		Equivalent to
			Input	Output	Inputs	Voltage	
66.00.350-6	6	MIL	35 pole, pin	17 pole, socket	2	programmable via MICT	
66.00.350-12	12	MIL	35 pole, pin	17 pole, socket	2	programmable via MICT	

## Input Harnesses for Ignition Controllers – Light Duty – Standard

P/N	Description	Interfaces	Connector	Length	Pickup
06.02.034-160	Input harness for P/N 66.00.350-6/-12	CAN Bus/RS485 (4 wire)	MIL, 35 pole, socket, 180°	160 in.	1 inductive
06.02.035-160	Input harness for P/N 66.00.350-6/-12	CAN Bus/RS485 (4 wire)	MIL, 35 pole, socket, 180°	160 in.	2 inductive
06.02.036-160	Input harness for P/N 66.00.350-6/-12	CAN Bus/RS485 (4 wire)	MIL, 35 pole, socket, 180°	160 in.	1 Hall effect

## Output Harnesses for Ignition Controllers – Light Duty – Standard <sup>1)</sup>

P/N	Description	Connector	Length	Equivalent to
95.40.217-L	Output harness for P/N 66.00.350-6/-12	MIL, 17 pole, pin, 180°	"L"= 5/15/25/50 ft.	

<sup>1)</sup> For CSA applications flex conduit has to be ordered separately or supplied by customer.

## Output Adaptor Harnesses for Ignition Controllers – Light Duty – Standard – Interface to ALTRONIC®

P/N	Description	Connector	Length	Equivalent to
06.02.027	Output adaptor harness for P/N 66.00.350-6/-12, use to replace ALTRONIC® CD200 ignition controller P/N 791070-6 , 791070-8	MIL, 17 pole, pin, 180°	12 in.	
06.02.028	Output adaptor harness for P/N 66.00.350-6/-12, use to replace ALTRONIC® CD200 ignition controller P/N 791070-12	MIL, 17 pole, pin, 180°	12 in.	
77.49.029-1	Output adaptor harness for P/N 66.00.350-6/-12, use to replace ALTRONIC® CPU95 ignition controller P/N 791950-16	MIL, 17 pole, pin, 180°	1 ft.	
77.49.029-5	Output adaptor harness for P/N 66.00.350-6/-12, use to replace ALTRONIC® CPU95 ignition controller P/N 791950-16	MIL, 17 pole, pin, 180°	5 ft.	
77.49.029-7	Output adaptor harness for P/N 66.00.350-6/-12, use to replace ALTRONIC® CPU95 ignition controller P/N 791950-16	MIL, 17 pole, pin, 180°	7 ft.	
77.49.029-10	Output adaptor harness for P/N 66.00.350-6/-12, use to replace ALTRONIC® CPU95 ignition controller P/N 791950-16	MIL, 17 pole, pin, 180°	10 ft.	

## Junction Box & Accessories

P/N	Figure	Description	Equivalent to
06.05.075	<b>1</b>	Junction box	
15.07.134	<b>2</b>	Flex conduit, 3/4 in., black <sup>1)</sup>	
15.07.231	<b>3</b>	Fitting, 3/4 in., junction box to flex conduit	

<sup>1)</sup> Flex conduit needs to be ordered in m/ft. in required quantity.

## Ignition Controllers – Light Duty – Special – Retrofit for CATERPILLAR® G3300 and G3400 Series Gas Engines

P/N	max. Outputs	Connector Style	Connectors			Pickup		Equivalent to
			Input	Output	Analog Input	Inputs	Voltage	
66.00.356-8	8	MIL	6 pole, pin	10 pole, pin	10 pole, socket	1	programmable via MICT	163-6164, 06.00.513
66.00.357-12	12	MIL	6 pole, pin	19 pole, pin	10 pole, socket	1	programmable via MICT	163-6108, 06.00.514

## Ignition Controllers – Light Duty – Special – Retrofit for WAUKESHA® VGF and VHP Series Gas Engines

P/N	max. Outputs	Connector Style	Connectors			Pickup		Equivalent to
			Input	Output	Analog Input	Inputs	Voltage	
66.00.358-8	8	MIL	7 pole, pin	10 pole, pin	10 pole, socket	1	programmable via MICT	740608A, 06.00.515-6/-8
66.00.359-12	12	MIL	7 pole, pin	19 pole, pin	10 pole, socket	1	programmable via MICT	740609A, 06.00.516

## Analog Input Harness for Ignition Controllers – Light Duty – Special

P/N	Description	Connector	Length	Equivalent to
06.02.046-160	Analog input harness for P/N 66.00.356-8, 66.00.357-12, 66.00.358-8, 66.00.359-12	MIL, 10 pole, pin, 180°	160 in.	



1



2



3



# Ignition Controllers & Harnesses



## Ignition Controllers – Light Duty – Standard

P/N	max. Outputs	Connector Style	Connectors		Pickup		Equivalent to
			Input	Output	Inputs	Voltage	
66.00.410-8	8	MIL/terminal strip	terminal strip	17 pole, socket	3	programmable via MICT	
66.00.410-16	16	MIL/terminal strip	terminal strip	17 pole, socket	3	programmable via MICT	
66.00.424-8	8	MIL	35 pole, pin	17 pole, socket	2	programmable via MICT	
66.00.424-16	16	MIL	35 pole, pin	17 pole, socket	2	programmable via MICT	

## Ignition Controllers – Light Duty – Standard (II 3G Ex nA IIB T4)



P/N	max. Outputs	Connector Style	Connectors		Pickup		Equivalent to
			Input	Output	Inputs	Voltage	
93.00.410-8	8	MIL/terminal strip	terminal strip	17 pole, socket	3	programmable via MICT	
93.00.410-16	16	MIL/terminal strip	terminal strip	17 pole, socket	3	programmable via MICT	

## Ignition Controllers – Panel Mount – Standard



P/N	max. Outputs	Connector Style	Connectors		Pickup		Equivalent to
			Input	Output	Inputs	Voltage	
66.00.400-8	8	terminal strip	terminal strip	terminal strip	3	programmable via MICT	
66.00.400-16	16	terminal strip	terminal strip	terminal strip	3	programmable via MICT	

## Ignition Controllers – Panel Mount – Standard (II 3G Ex nA IIB T4 X)<sup>1)</sup>



P/N	max. Outputs	Connector Style	Connectors		Pickup		Equivalent to
			Input	Output	Inputs	Voltage	
93.00.400-8	8	terminal strip	terminal strip	terminal strip	3	programmable via MICT	
93.00.400-16	16	terminal strip	terminal strip	terminal strip	3	programmable via MICT	

<sup>1)</sup> Ignition controllers built into stainless steel enclosure.

## Ignition Controllers – Heavy Duty – Standard



P/N	max. Outputs	Connector Style	Connectors		Pickup		Equivalent to
			Input	Output	Inputs	Voltage	
66.00.440-8	8	MIL/terminal strip	terminal strip	17 pole, socket	3	programmable via MICT	
66.00.440-16	16	MIL/terminal strip	terminal strip	17 pole, socket	3	programmable via MICT	

## Input Harnesses for Ignition Controllers – Light Duty – Standard

P/N	Description	Interfaces	Connector	Length	Pickup
06.02.034-160	Input harness for P/N 66.00.424-8/-16	CAN Bus/RS485 (4 wire)	MIL, 35 pole, socket, 180°	160 in.	1 inductive
06.02.035-160	Input harness for P/N 66.00.424-8/-16	CAN Bus/RS485 (4 wire)	MIL, 35 pole, socket, 180°	160 in.	2 inductive
06.02.036-160	Input harness for P/N 66.00.424-8/-16	CAN Bus/RS485 (4 wire)	MIL, 35 pole, socket, 180°	160 in.	1 Hall effect

Light Duty (LD)



Panel Mount (PM)



Heavy Duty (HD)



back

# Ignition Controllers & Harnesses



## Output Harnesses for Ignition Controllers – Light Duty/Heavy Duty – Standard <sup>1)</sup>

P/N	Description	Connector	Length	Equivalent to
95.40.217-L	Output harness for P/N 66.00.410-8/-16, P/N 66.00.424-8/-16 and P/N 66.00.440-8/-16	MIL, 17 pole, pin, 180°	"L"= 5/15/25/50 ft.	

<sup>1)</sup> For CSA applications flex conduit has to be ordered separately or supplied by customer.

## Output Adaptor Harnesses for Ignition Controllers – Light Duty – Standard – Interface to ALTRONIC®

P/N	Description	Connector	Length	Equivalent to
06.02.027	Output adaptor harness for P/N 66.00.410-8/-16, P/N 66.00.424-8/-16 and P/N 66.00.440-8/-16, use to replace ALTRONIC® CD200 ignition controller P/N 791070-6, 791070-8	MIL, 17 pole, pin, 180°	12 in.	
06.02.028	Output adaptor harness for P/N 66.00.410-8/-16, P/N 66.00.424-8/-16 and P/N 66.00.440-8/-16, use to replace ALTRONIC® CD200 ignition controller P/N 791070-12	MIL, 17 pole, pin, 180°	12 in.	
77.49.029-1	Output adaptor harness for P/N 66.00.410-8/-16, P/N 66.00.424-8/-16 and P/N 66.00.440-8/-16, use to replace ALTRONIC® CPU95 ignition controller P/N 791950-16	MIL, 17 pole, pin, 180°	1 ft.	
77.49.029-5	Output adaptor harness for P/N 66.00.410-8/-16, P/N 66.00.424-8/-16 and P/N 66.00.440-8/-16, use to replace ALTRONIC® CPU95 ignition controller P/N 791950-16	MIL, 17 pole, pin, 180°	5 ft.	
77.49.029-7	Output adaptor harness for P/N 66.00.410-8/-16, P/N 66.00.424-8/-16 and P/N 66.00.440-8/-16, use to replace ALTRONIC® CPU95 ignition controller P/N 791950-16	MIL, 17 pole, pin, 180°	7 ft.	
77.49.029-10	Output adaptor harness for P/N 66.00.410-8/-16, P/N 66.00.424-8/-16 and P/N 66.00.440-8/-16, use to replace ALTRONIC® CPU95 ignition controller P/N 791950-16	MIL, 17 pole, pin, 180°	10 ft.	



## Junction Box & Accessories

P/N	Figure	Description	Equivalent to
06.05.075	1	Junction box	
93.05.075	1	Junction box (II 3G Ex e nA IIA T4)	
15.07.134	2	Flex conduit, 3/4 in., black <sup>1)</sup>	
15.07.231	3	Fitting, 3/4 in., junction box to flex conduit	

<sup>1)</sup> Flex conduit needs to be ordered in m/ft. in required quantity.

## Bracket Sets for Conversions

P/N	Description	Equivalent to
75.10.404	Bracket set for conversion of ALTRONIC® CPU95 ignition controller to MIC4 Light Duty/Heavy Duty	
75.30.146	Universal adaptor plate – MIC4 Light Duty/Heavy Duty	



1



2



3

## Ignition Controllers & Harnesses



Based on the MIC4 series, MOTORTECH produces a special controller version as a replacement for the TEM-ZS1 and TEM-ZS3 ignition system used on MWM®/DEUTZ® gas engines. Designed as an exchange device, the MIC4-ZS enables a quick conversion without great effort.

In addition to the MIC4-ZS ignition controller, the prepared conversion kits include the required high-performance ignition coils. Pre-chamber spark plugs or spark plug leads can be re-used, as these ignition coils have the same secondary connections as the original ones. The ignition coils – designed for MOTORTECH ignition controllers with MOST technology – guarantee the ideal performance support, especially when it comes to alternative combustibles with alternating or relatively low fuel value, e.g. biogas, mine gas, woodgas, sewage gas, landfill gas etc.



### MIC4-ZS Kits

P/N	Description	Quantity	Equivalent to
75.30.150-08	MIC4-ZS kit for MWM®/DEUTZ® 8 cylinder engines <i>Contains:</i> <ul style="list-style-type: none"> <li>• MIC4-ZS ignition controller P/N 66.00.425-16</li> <li>• High-performance ignition coil P/N 06.50.065</li> </ul>	1 pc. 8 pcs.	1229 8101 KM (TEM-ZS1) 1232 0993 KZ (TEM-ZS3)
75.30.150-12	MIC4-ZS kit for MWM®/DEUTZ® 12 cylinder engines <i>Contains:</i> <ul style="list-style-type: none"> <li>• MIC4-ZS ignition controller P/N 66.00.425-16</li> <li>• High-performance ignition coil P/N 06.50.065</li> </ul>	1 pc. 12 pcs.	1229 8101 KM (TEM-ZS1) 1232 0993 KZ (TEM-ZS3)
75.30.150-16	MIC4-ZS kit for MWM®/DEUTZ® 16 cylinder engines <i>Contains:</i> <ul style="list-style-type: none"> <li>• MIC4-ZS ignition controller P/N 66.00.425-16</li> <li>• High-performance ignition coil P/N 06.50.065</li> </ul>	1 pc. 16 pcs.	1229 8101 KM (TEM-ZS1) 1232 0993 KZ (TEM-ZS3)

### Accessories (optional)

P/N	Description	Quantity	Equivalent to
06.85.179-20	PolyMot™ spark plug lead for MWM®/DEUTZ® <ul style="list-style-type: none"> <li>• TBG620 series</li> <li>• TCG2020 series</li> </ul>	8, 12 or 16 pcs. per kit	1230 0136
06.85.310H-11	PolyMot™ spark plug lead for MWM®/DEUTZ® <ul style="list-style-type: none"> <li>• TBG616 series</li> <li>• TCG2016 series</li> </ul>	8, 12 or 16 pcs. per kit	1227 8370
GL3-3	DENSO® spark plug <ul style="list-style-type: none"> <li>• Thread M18x1.5, reach 19 mm/0.750 in.</li> <li>• Hex 20.8 mm/13/16 in.</li> <li>• Iridium/platinum alloy</li> <li>• <b>Recommended for natural gas applications</b></li> </ul>	8, 12 or 16 pcs. per kit	1242 0290, 1242 0480
GL3-5	DENSO® spark plug <ul style="list-style-type: none"> <li>• Thread M18x1.5, reach 19 mm/0.750 in.</li> <li>• Hex 20.8 mm/13/16 in.</li> <li>• Iridium/iridium alloy</li> <li>• <b>Recommended for special gas/natural gas applications</b></li> </ul>	8, 12 or 16 pcs. per kit	1242 0290, 1242 0480
alternative B8324	MOTORTECH MHP spark plug <ul style="list-style-type: none"> <li>• Thread M18x1.5, reach 19 mm/0.750 in.</li> <li>• Hex 20.8 mm/13/16 in.</li> <li>• Iridium/iridium alloy</li> <li>• <b>Recommended for special gas/natural gas applications</b></li> </ul>	8, 12 or 16 pcs. per kit	1242 0290, 1242 0480

# Ignition Controllers & Harnesses



Ignition Systems

## Ignition Controllers – Heavy Duty – Standard

P/N	max. Outputs	Connector Style	Connectors		Pickup		Equivalent to
			Input	Output	Inputs	Voltage	
66.00.540-20	20	MIL/terminal strip	terminal strip	35 pole, socket	3	programmable via MICT	
66.00.541-20	20	MIL	35 pole, pin	35 pole, socket	2	programmable via MICT	

## Input Harnesses for Ignition Controllers – Heavy Duty – Standard

P/N	Description	Interfaces	Connector	Length	Pickup
06.02.034-160	Input harness for P/N 66.00.541-20	CAN Bus/RS485 (4 wire)	MIL, 35 pole, socket, 180°	160 in.	1 inductive
06.02.035-160	Input harness for P/N 66.00.541-20	CAN Bus/RS485 (4 wire)	MIL, 35 pole, socket, 180°	160 in.	2 inductive
06.02.036-160	Input harness for P/N 66.00.541-20	CAN Bus/RS485 (4 wire)	MIL, 35 pole, socket, 180°	160 in.	1 Hall effect

## Output Harnesses for Ignition Controllers – Heavy Duty – Standard <sup>1)</sup>



P/N	Description	Connector	Length	Equivalent to
95.40.235-L	Output harness for P/N 66.00.540-20 and P/N 66.00.541-20	MIL, 35 pole, pin, 180°	"L"= 5/15/25/50 ft.	

<sup>1)</sup> For CSA applications flex conduit has to be ordered separately or supplied by customer.

## Ignition Controllers – Heavy Duty – Special



P/N	max. Outputs	Connector Style	Connectors		Pickup		Equivalent to
			Input	Output	Inputs	Voltage	
66.00.542-20	20	MIL/terminal strip	terminal strip	14/17 pole, socket	3	programmable via MICT	WOODWARD® IC9xx, MIC850 P/N 66.00.851-24/-24-D

## Ignition Controllers – Heavy Duty – Special (II 3G Ex nA IIB T4 X)



P/N	max. Outputs	Connector Style	Connectors		Pickup		Equivalent to
			Input	Output	Inputs	Voltage	
93.00.542-20	20	MIL/terminal strip	terminal strip	14/17 pole, socket	3	programmable via MICT	WOODWARD® IC9xx, MIC850 P/N 66.00.851-24/-24-D

## Output Harnesses for Ignition Controllers – Heavy Duty – Special <sup>1)</sup>



P/N	Description	Connector	Length	Equivalent to
95.40.214-L	Output harness for P/N 66.00.542-20	MIL, 14 pole, pin, 180°	"L"= 5/15/25/50 ft.	
95.40.217-L	Output harness for P/N 66.00.542-20	MIL, 17 pole, pin, 180°	"L"= 5/15/25/50 ft.	

<sup>1)</sup> For CSA applications flex conduit has to be ordered separately or supplied by customer.

# Ignition Controllers & Harnesses

## Output Adaptor Harnesses for Ignition Controllers – Heavy Duty – Standard/Special – Interface to ALTRONIC®/WOODWARD®

P/N	Description	Connector	Length	Equivalent to
77.49.006	Output adaptor harness for P/N 66.00.540-20 and P/N 66.00.541-20, use to replace WOODWARD® IC9xx ignition controller and MIC850 P/N 66.00.851-24/-24-D	MIL, 35 pole, pin, 90°	16 in.	
77.49.007-1	Output adaptor harness for P/N 66.00.540-20 and P/N 66.00.541-20, use to replace ALTRONIC® CPU95 ignition controller P/N 791950-16	MIL, 35 pole, pin, 90°	1 ft.	
77.49.007-5	Output adaptor harness for P/N 66.00.540-20 and P/N 66.00.541-20, use to replace ALTRONIC® CPU95 ignition controller P/N 791950-16	MIL, 35 pole, pin, 90°	5 ft.	
77.49.007-7	Output adaptor harness for P/N 66.00.540-20 and P/N 66.00.541-20, use to replace ALTRONIC® CPU95 ignition controller P/N 791950-16	MIL, 35 pole, pin, 90°	7 ft.	
77.49.007-10	Output adaptor harness for P/N 66.00.540-20 and P/N 66.00.541-20, use to replace ALTRONIC® CPU95 ignition controller P/N 791950-16	MIL, 35 pole, pin, 90°	10 ft.	
77.49.008	Output adaptor harness for P/N 66.00.540-20 and P/N 66.00.541-20, use to replace MIC750 ignition controller P/N 66.00.750/-D	MIL, 35 pole, pin, 90°	16 in.	

## Junction Box & Accessories



P/N	Figure	Description	Equivalent to
06.05.075	1	Junction box	
93.05.075	1	Junction box (II 3G Ex e nA IIA T4)	
15.07.134	2	Flex conduit, 3/4 in., black <sup>1)</sup>	
15.07.231	3	Fitting, 3/4 in., junction box to flex conduit	

<sup>1)</sup> Flex conduit needs to be ordered in m/ft. in required quantity.



1



2



3

## MIC6 MOTORTECH IGNITION CONTROLLER

### MIC6 Ignition Controller For Stationary and Marine Applications

MOTORTECH expands its MIC product line with the new MIC6 series. The latest development is ideally suited for medium and high speed applications and convinces with a future oriented electronical concept for more power and a significantly higher degree of efficiency.

The specially developed MIC6-Marine version meets the strict technical requirements of marine applications and certification societies and comes with extra features like a redundant pickup setup.

#### General

- For medium (900 rpm nominal) and high speed applications (1500 rpm nominal)
- 1000 mJ primary energy max.
- Adjustable spark duration and intensity
- Constant spark intensity via adjusted duration
- 6 pickup inputs for redundant pickup setup

#### Technical Data & Features

- 18 to 32 VDC supply voltage
- 24 ignition outputs
- 250 VDC primary voltage
- 1000 mJ primary energy (when firing 24 outputs at 900 rpm)  
600 mJ primary energy (when firing 24 outputs at 1500 rpm)
- 0.1° crankshaft accuracy
- 6 pickup inputs for integration of 2 redundant pickup sets
- Triggered by 1, 2 or 3 pickups per set (magnetic, Hall effect or inductive/configurable)
- Multiple ignition timing control via
  - Speed curve
  - 0 to 20 mA analog input
  - 0 to 10 V analog input
- Multiple energy control via MOST (MOTORTECH Output Stage Technology)
- Programmable firing order
- 3 multipurpose outputs (GPO)
- 2 Auxiliary Synchronization Outputs (ASO) which can support a detonation control system (e.g. DetCon) or fuel injection pump controllers
- Ignition release input
- Go/NoGo output
- Overspeed shutdown function
- Access controlled

<sup>1)</sup> Certification for MIC6 series in preparation.



- Ignition diagnostics (primary and secondary)
- More internal memory for faster signal processing and trend data for advanced diagnostics
- Integrated CANopen and RS485 (Modbus RTU) interface
- Easy access per USB port

#### Ignition Diagnostics

- Runtime data
- Alarm and error messages
- Data logging
- Primary and secondary misfire detection
- Cylinder individual high voltage calculation (kV)
- 11 LEDs provide a quick system state overview

#### Interfaces

- CAN Bus 2.0b interface (CANopen/SAE J1939 protocol)
- RS485 interface (Modbus RTU)
- USB 1.1 interface

#### Configuration

- Using the graphic user interface MICT (MOTORTECH Integrated Configuration Tool)

#### Housing/Connections

- Protection class IP65
- MIL style connectors

#### Certifications

- CSA (Class I, Division 2, Group C, D; T4) <sup>1)</sup>
- Marine type approval certification in accordance with DNV GL, Bureau Veritas, Lloyd's Register <sup>1)</sup>
- ATEX (II 3G EX nA IIB T4 X) – on request
- CE

# Ignition Controllers & Harnesses

## System Overview MIC6 Series

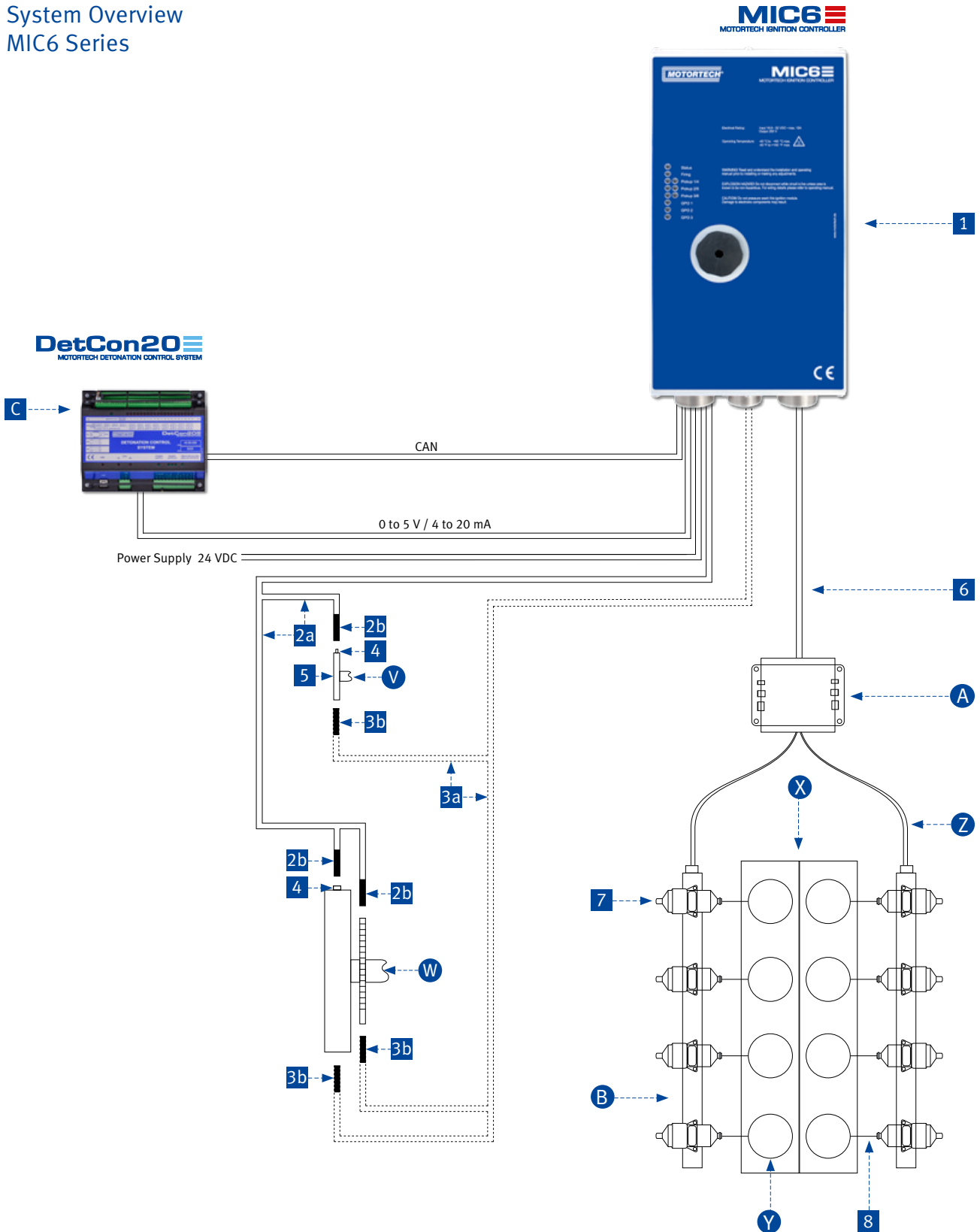



## Legend

### Necessary Components

- 1 MIC6 ignition controller
- 2 Pickup – Set 1
  - 2a Pickup lead\*
  - 2b Pickup\*
- 3 Pickup – Set 2 (for redundant purposes)
  - 3a Pickup lead\*
  - 3b Pickup\*
- 4 Trigger pins/magnets
 

*alternative*
- 5 Trigger disc
 

*alternative*

Trigger drive
- 6 Output harness\*
- 7 Ignition coil\*
- 8 1 Primary lead/spark plug lead per ignition coil\*

\* Shielded and unshielded versions available.

### Accessories

- A Junction box
- B AlphaRail-/ LiteRail – ignition wiring rail

### System Enhancement

- C DetCon20 – Detonation controller

### Description

- V Camshaft
- W Crankshaft
- X Engine
- Y Cylinder
- Z Harness to connect the ignition wiring rails and the junction box

## Established Pickup Arrangements

### 3-Pickup Arrangement for 4-Stroke Engines

- 1) Crankshaft (Reset)  
Magnetic pickup  
(holes, pins, teeth, screws)
- 2) Crankshaft (Speed)  
Magnetic pickup  
(holes, pins, teeth, screws)
- 3) Camshaft (Reset)  
Hall effect pickup  
(magnets)

*alternative*

- 3) Camshaft (Reset)  
Inductive pickup  
(pins, screws, slots)

### 1-Pickup Arrangement for 4-Stroke Engines

- 1) Camshaft (N+1/N-1)  
Hall effect pickup  
(disc with magnets)
- alternative*
- 1) Camshaft (N+1/N-1)  
Inductive pickup  
(disc with pins, screws, slots)

### 2-Pickup Arrangement for 2-Stroke Engines

- 1) Crankshaft (Reset)  
Magnetic pickup  
(holes, pins, teeth, screws)
- 2) Crankshaft (Speed)  
Magnetic pickup  
(holes, pins, teeth, screws)

# Ignition Controllers & Harnesses



MOST

## MIC6 Ignition Controller for Stationary Applications

### Ignition Controllers – Heavy Duty – Standard

P/N	max. Outputs	Connector Style	Connectors		Pickup		Equivalent to
			Input	Output	Inputs	Voltage	
66.00.645-24	24	MIL	35 pole, pin	35 pole, socket	3	programmable via MICT	
66.00.646-24	24	MIL	35/26 pole, pin	35 pole, socket	6	programmable via MICT	
66.00.647-24	24	MIL/terminal strip	terminal strip	35 pole, socket	6	programmable via MICT	

### Input Harnesses for Ignition Controllers – Heavy Duty – Standard

P/N	Description	Interfaces	Connector	Length	Pickup
06.02.048-160	Input harness for P/N 66.00.645-24 and P/N 66.00.646-24	CAN Bus (4 wire)	MIL, 35 pole, socket, 180°	160 in.	1 inductive, 2 magnetic
06.02.049-160	Input harness for P/N 66.00.646-24	CAN Bus/RS485 (4 wire)	MIL, 26 pole, socket, 180°	160 in.	1 inductive, 2 magnetic

### Output Harnesses for Ignition Controllers – Heavy Duty – Standard <sup>1)</sup>



P/N	Description	Connector	Length	Equivalent to
95.40.235-L	Output harness for P/N 66.00.645-24, P/N 66.00.646-24 and P/N 66.00.647-24	MIL, 35 pole, pin, 180°	"L"= 5/15/25/50ft.	

<sup>1)</sup> For CSA applications flex conduit has to be ordered separately or supplied by customer.

### Junction Box & Accessories



P/N	Figure	Description	Equivalent to
06.05.075	<b>1</b>	Junction box	
15.07.134	<b>2</b>	Flex conduit, 3/4 in., black <sup>1)</sup>	
15.07.231	<b>3</b>	Fitting, 3/4 in., junction box to flex conduit	

<sup>1)</sup> Flex conduit needs to be ordered in m/ft. in required quantity.



**1**



**2**



**3**

# Ignition Controllers & Harnesses



## MIC6-Marine MOTORTECH IGNITION CONTROLLER



### MIC6 Ignition Controller for Marine Applications

Ignition Controllers – **Heavy Duty** – Standard

MOST

P/N	max. Outputs	Connector Style	Connectors		Pickup		Equivalent to
			Input	Output	Inputs	Voltage	
92.00.646-24	24	MIL	35/26 pole, pin	35 pole, socket	6	programmable via MICT	

### Input Harnesses for Ignition Controllers – **Heavy Duty** – Standard

P/N	Description	Interfaces	Connector	Length	Pickup
92.02.001-160	Input harness for P/N 92.00.646-24	CAN Bus (4 wire)	MIL, 35 pole, socket, 180°	160 in.	1 inductive, 2 magnetic
92.02.002-160	Input harness for P/N 92.00.646-24	CAN Bus/RS485 (4 wire)	MIL, 26 pole, socket, 180°	160 in.	1 inductive, 2 magnetic

**NOTE:** Please consult factory for individual layout of Marine certified output harnesses.

Ignition Systems

# Ignition Controllers & Harnesses



## Ignition Control Visualization

The operating data of MIC3/3+, MIC4 and MIC5 series ignition controllers will be completely visualized via HMI module (Human Machine Interface). The overview screen shows the relevant information as engine speed, ignition timing and status of pickups, ignition outputs or active parameter set.

The PowerView3 also allows justification of various ignition parameters such as ignition timing and energy. Functions as the self-test for error diagnostics can also be executed via HMI module. The control keys guarantee simple navigation through different display pages and menus. All in all the PowerView3 HMI module is also able to provide error diagnostics on-site without requiring a laptop!

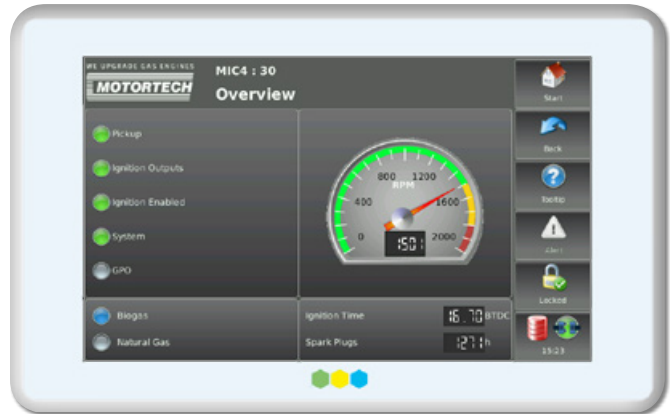

1

The PowerView3 is also available for data visualization of:

- DetCon Detonation Control
- TempScan20 Temperature Module

## General Features

- Visualization of ignition, detonation and temperature control via CAN bus
- Access control
- Display of CAN connection status
- Several display configurations (languages, date, display calibration, etc.)
- For assembly in control panels
- Day and night mode
- CSA® certified (Class I, Div. 2, Group C, D; T4)

## Ignition Control (MIC3/3+/MIC4/MIC5 series)

- Overview with status indication for
  - Pickup signals
  - Active schedule
  - Analog display of engine speed
  - Ignition timing
  - Spark plugs (operating hours)
- Display of global ignition timing dependent on
  - Base ignition timing
  - Potentiometer adjustment
  - Analog current and voltage input
  - Speed curve
- Displays the ignition of each cylinder
  - Ignition voltage
- Misfires
  - Display of misfires
    - Primary and secondary sided wiring errors
    - Type of error (no connection/short circuit)
  - Display and adjustment of energy
    - Spark duration
    - Spark intensity
  - Display and adjustment of firing angles and ignition energy
  - Self-test activation
  - Warning, alarm and error messages

## Sample Screens – MIC3/3+/MIC4/MIC5

### MIC Overview



- Status displays (pickup, ignition outputs, ignition enabled, system status, schedule)
- Displays the current engine speed
- Shows the current global ignition timing in ° crankshaft
- Displays the previous operating hours of the spark plugs

### Ignition

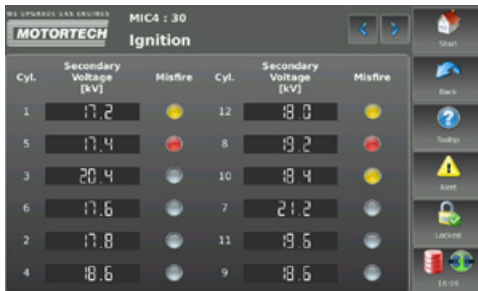

- Displays the estimated ignition voltage for each individual cylinder
- Display of current and past misfires of each individual cylinder

### Secondary Voltage

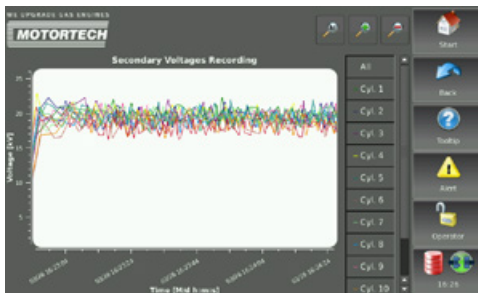

- Display of estimated secondary voltage of all selected cylinders
- Cylinders can be displayed and hidden individually
- Zoom function for detailed view of secondary voltage
- Navigation within the timeline

## PowerView3 HMI Modules & Activation Codes



P/N	Figure	Description
06.05.085	1	PowerView3 HMI module
06.05.185	2	PowerView3 HMI module, built into stainless steel enclosure
06.05.186	3	PowerView3 HMI modules (2 pcs.), built into stainless steel enclosure, incl. activation codes for visualization of MIC3/3+/MIC4/MIC5 data, for use with dual ignition controller applications
06.05.086-F		PowerView3 activation code for visualization of MIC3/3+/MIC4/MIC5 data – Activation code has to be ordered separately with each PowerView3 HMI module
06.05.086-U		PowerView3 activation code for visualization of MIC3/3+/MIC4/MIC5 data – Only available for upgrade of existing PowerView3 HMI module in the field



# Ignition Controllers & Harnesses

## MOT601 MOTORTECH SINGLE CYLINDER IGNITION SYSTEM

The self-powered MOT601 is a Capacitor Discharge (CD) Ignition System for use on spark-ignited, single cylinder engines with large flywheels. Engine mounted, very close to the flywheel, the electronic components are supplied with power by magnetic charging circuitry.

### Features

- Applicable for single cylinder applications with different flywheel sizes
- Self-powered electromagnetic system, no need for external power
- High primary energy
- Using crankshaft reference timing
- High accuracy ignition timing
- 2 separate ignition timings (startup and nominal)
- Safety shutdown input
- Supplies panel power

### Benefits

- Price effective system and parts
- Mainly maintenance-free system due to non-moving parts that wear out
- All components available as spare parts and interchangeable with competitor products
- 1 year warranty



### Mode of Operation

The charging bar **5** with three strong magnets attached to the flywheel passes the charging generator module **3** that is attached to the engine in a fixed position at every revolution of the flywheel. At every revolution the generator module charges a capacitor in the electronic ignition module **2** as a result of the magnetic field.

The trigger bar **6** with two magnets, which is likewise attached to the flywheel, passes a pickup coil **4** that is attached to the engine in a fixed position at every revolution of the engine. When the trigger bar passes the pickup coil, the energy stored in the capacitor is discharged into the attached ignition coil **7**.

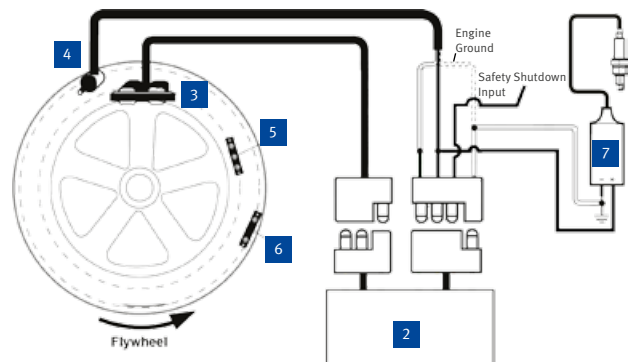

## Ignition System for Single Cylinder Engines

P/N	Figure	Description	Equivalent to
MOT601	1	MOT601 ignition system for single cylinder engines	AEI® FM601, ARROW® SFI-KIT, MURPHY® 72-70-0125

## Subcomponents

P/N	Figure	Description	Equivalent to
M-400A-8814	2	Electronic ignition module	AEI® 400A-8814, ARROW® A400A-8814, MURPHY® 72-00-0024,
M-260D-8810	3	Charging generator	AEI® 260D-8810, ARROW® A260D-8810, MURPHY® 72-00-0025
M-270A-8817	4	Magnetic pickup harness	AEI® 270A-8817, ARROW® A400A-8817, MURPHY® 72-00-0026
M-400A-8813	5	Magnetic charging bar	AEI® 400A-8813, ARROW® A400A-8813, MURPHY® 72-00-0027
M-400A-8811	6	Magnetic trigger bar	AEI® 400A-8811, ARROW® A400A-8811, MURPHY® 72-00-0028
06.50.055	7	Ignition coil	AEI® 1187, ARROW® 330-2-AI-46, MURPHY® 72-70-0235

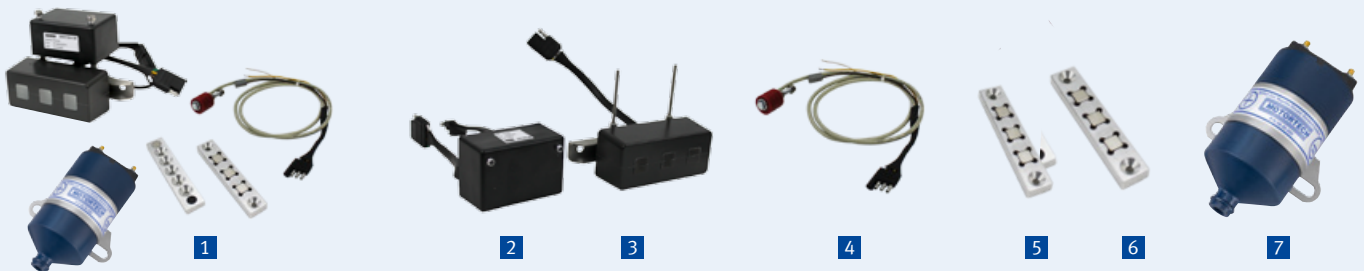



# Ignition Controllers & Harnesses

UNSHIELDED

## Harnesses for Competition Ignition Control Systems

For use with ALTRONIC® magneto ignition systems, MOTORTECH offers a special range of harnesses. Based on the reliable design and quality of MOTORTECH's standard harnesses, this series represents a suitable replacement for existing competitor harnesses in the field.

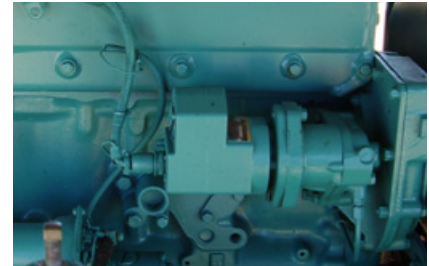

### Output Harnesses for ALTRONIC® Ignition Magnetos

P/N	Figure	Description	Connector	Length	Equivalent to
06.31.030-1	1	Output harness for ALT III ignition magneto, for unshielded applications up to 8 cylinders	MIL, 14 pole, socket, 180°	180 in.	393018-1, 2W-3742, 69703, 178622
06.31.030-2	1	Output harness for ALT III ignition magneto, for unshielded applications up to 12 cylinders	MIL, 14 pole, socket, 180°	180 in.	383018-2, 2W-3744, 269717B
06.31.032-1	1	Output harness for ALT III/III-CPU/V ignition magneto, CPU95-EVS (ignition unit to J-Box or DC-DC power supply), for unshielded applications up to 6 cylinders	MIL, 7 pole, socket, 180°	72 in.	393023-1
06.31.032-2	1	Output harness for ALT III/III-CPU/V ignition magneto, CPU95-EVS (ignition unit to J-Box or DC-DC power supply), for unshielded applications up to 6 cylinders	MIL, 7 pole, socket, 180°	180 in.	393023-2, 2W-3748, 69692B
06.77.006-72	1	Output harness for ALT V ignition magneto, for unshielded applications up to 6 cylinders	MIL, 5 pole, socket, 180°	72 in.	593041-1, 209728
06.77.006-96	1	Output harness for ALT V ignition magneto, for unshielded applications up to 6 cylinders	MIL, 5 pole, socket, 180°	96 in.	593041-2



1

## Output Harnesses for ALTRONIC® Ignition Magnets

P/N	Figure	Description	Connector	Length		Equivalent to
				Conduit	Conductor	
95.30.008-1	2	Output harness for ALT III/III-CPU ignition magneto, for shielded applications up to 8 cylinders	MIL, 14 pole, socket, 90°	48 in.	180 in.	393014-1
95.30.008-2	2	Output harness for ALT III/III-CPU ignition magneto, for shielded applications up to 12 cylinders	MIL, 14 pole, socket, 90°	48 in.	180 in.	393014-2
95.30.008-3	2	Output harness for ALT III/III-CPU ignition magneto, for shielded applications up to 8 cylinders	MIL, 14 pole, socket, 90°	20 in.	42 in.	393014-3, 178803
95.30.008-4	2	Output harness for ALT III/III-CPU ignition magneto, for shielded applications up to 12 cylinders	MIL, 14 pole, socket, 90°	48 in.	72 in.	393014-4, 4W-5466, 208502C
95.30.008-5	2	Output harness for ALT III/III-CPU ignition magneto, for shielded applications up to 8 cylinders	MIL, 14 pole, socket, 90°	120 in.	300 in.	393014-5
95.30.008-6	2	Output harness for ALT III/III-CPU ignition magneto, for shielded applications up to 12 cylinders	MIL, 14 pole, socket, 90°	120 in.	300 in.	393014-6
95.30.008-7	2	Output harness for ALT III/III-CPU ignition magneto, for shielded applications up to 8 cylinders	MIL, 14 pole, socket, 90°	48 in.	72 in.	393014-7, 4W-5468
95.30.008-8	2	Output harness for ALT III/III-CPU ignition magneto, for shielded applications up to 12 cylinders	MIL, 14 pole, socket, 90°	36 in.	60 in.	393014-8, 178804
95.30.008-9	2	Output harness for ALT III/III-CPU ignition magneto, for shielded applications up to 12 cylinders	MIL, 14 pole, socket, 90°	66 in.	96 in.	393014-9
95.30.008-10	2	Output harness for ALT III/III-CPU ignition magneto, for shielded applications up to 8 cylinders	MIL, 14 pole, socket, 90°	48 in.	60 in.	393014-10
95.30.008-11	2	Output harness for ALT III/III-CPU ignition magneto, for shielded applications up to 8 cylinders	MIL, 14 pole, socket, 90°	36 in.	60 in.	393014-11



2

# Ignition Coils

## UNSHIELDED

### New MOTORTECH Style

Ignition coils are becoming more and more important in modern, state of the art ignition systems. MOTORTECH offers a series of high performance ignition coils produced in its European facilities which are specially designed for use with newest technologies of MOTORTECH ignitions controllers:

- MOST – MOTORTECH Output Stage Technology of MOTORTECH MIC3/3+, MIC4, MIC5 and MIC6 ignition controllers
- Ideally suited for ignition of alternative fuels such as biogas



P/N	Color	Primary Termination	HV Termination	Polarity	MOST	Equivalent to
06.50.100	red	#10-32 UNF studs	M6	(-) ground	x	
06.50.102	red	#10-32 UNF studs	female	(-) ground	x	
06.50.104 <sup>1)</sup>	blue	#10-32 UNF studs	M6	(-) ground	x	
06.50.105 <sup>1)</sup>	blue	#10-32 UNF studs	female	(-) ground	x	
06.50.112	blue	#10-32 UNF studs	M6	(-) ground	x	
06.50.113	blue	#10-32 UNF studs	female	(-) ground	x	
06.50.300 <sup>2)</sup>	blue	#10-32 UNF studs	M6	(-) ground	x	
06.50.301 <sup>2)</sup>	blue	#10-32 UNF studs	female	(-) ground	x	

<sup>1)</sup> Ignition coils only available as spare parts. <sup>2)</sup> Only for use with MIC3/3+ ignition controllers.

## MOST

MOTORTECH OUTPUT STAGE TECHNOLOGY

MOST\* works with the following principles:

- adjustable ignition spark duration with different available ignition voltages
- constant spark intensity via adjusted ignition spark duration
- 300 to 1000 mJ of primary energy (device dependent) are available

\* Patented Technology US 8,893,692 B2

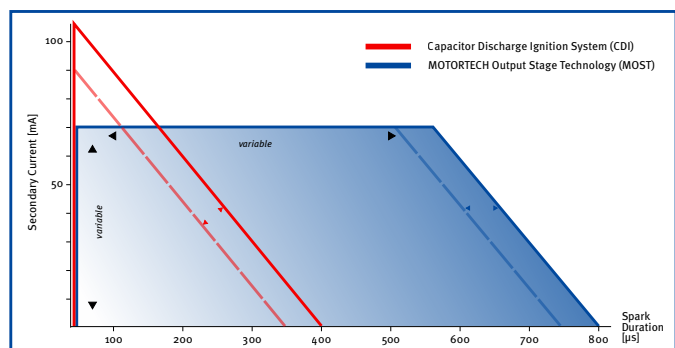

# Ignition Coils



## MOTORTECH Style

Several EPOXY ignition coils with different ignition characteristics are available for unshielded applications. These coils, commonly used with MIC500 and MIC850 or ALTRONIC® CPU95 series ignition controllers, feature a screw type high voltage termination and are designed to function with the appropriate high voltage indication systems.



Ignition Systems

P/N	Supersedes	Color	Primary Termination	HV Termination	Polarity	MOST	Equivalent to
06.50.003 <sup>1)</sup>	06.50.007	black	#10-32 UNF studs	M6	(-) ground	not applicable	118257
06.50.060 <sup>2)</sup>		black	#10-32 UNF studs	M6	(-) ground	not applicable	76.64.302

<sup>1)</sup> For use with MIC500 and MIC850 ignition controllers.

<sup>2)</sup> For use with ALTRONIC® CPU95 ignition controllers.

## ALTRONIC® Style

For existing installations with ALTRONIC® ignition coils, MOTORTECH offers a series of replacement products. The ignition coils are designed to have the same characteristics in regards of standard and extended duration as well as the electrical characteristics to function with the ALTRONIC® patented “Spark Reference” high voltage indication system. See chart below for cross reference numbers.



P/N	Color	Primary Termination	HV Termination	Polarity	MOST	Equivalent to
06.50.053	black	#10-32 UNF studs	female	(+) ground	not applicable	291001, 1215 3964
06.50.054	red	#10-32 UNF studs	female	(-) ground	not applicable	591010, Z00-17-001-00, 837/13 69694B, 4W-5439
06.50.055	blue	#10-32 UNF studs	female	(-) ground	not applicable	501061, Z00-17-000-00, 837/12, 69694, 2W-3747, 76.64.005, 1215 3965
06.50.065	black	#10-32 UNF studs	female	(-) ground	x	

Thousands of smaller gas engines (including CUMMINS®) are equipped with low cost ignition controllers like ALTRONIC® CD1 or CD200 series that use this compact coil. MOTORTECH offers an alternative.



P/N	Color	Primary Termination	HV Termination	Polarity	MOST	Equivalent to
06.50.103	black	#10-32 UNF studs	male	(-) ground	not applicable	591040, 3394578

# Ignition Coils

## UNSHIELDED

### Ignition Coils for CATERPILLAR® Gas Engines

The rising demand for specialized ignition coils has led MOTORTECH to the decision to design a new series of ignition coils, specially made for use with CATERPILLAR® gas engines.

- Compatible with original ignition coils
- Support CATERPILLAR® ignition systems
- Made in Europe



#### For CATERPILLAR® G3400/C & G3500/B/C/E/H Series Gas Engines (Non CSA Applications)

P/N	Color	Primary Termination	HV Termination	Polarity	MOST	Equivalent to
06.50.141	white	DEUTSCH® connector	female	(-) ground	not applicable	437-4049, 232-6348, 165-1591, 131-3277, 129-8802, 108-0615
06.50.145 <sup>1)</sup>	white	DEUTSCH® connector	female	(-) ground	X	437-4049, 232-6348, 165-1591, 131-3277, 129-8802, 108-0615
06.50.143	white	DEUTSCH® connector	female	(-) ground	not applicable	232-6352, 213-7443
06.50.147 <sup>1)</sup>	white	DEUTSCH® connector	female	(-) ground	X	232-6352, 213-7443
06.50.151	white	DEUTSCH® connector	female	(-) ground	not applicable	418-4861, 232-6346, 165-1589, 124-0749
06.50.155 <sup>1)</sup>	white	DEUTSCH® connector	female	(-) ground	X	418-4861, 232-6346, 165-1589, 124-0749
06.50.153	white	DEUTSCH® connector	female	(-) ground	not applicable	437-4106, 232-6350, 199-9011
06.50.157 <sup>1)</sup>	white	DEUTSCH® connector	female	(-) ground	X	437-4106, 232-6350, 199-9011
06.50.159	white	DEUTSCH® connector	female	(-) ground	not applicable	356-3701
06.50.160 <sup>1)</sup>	white	DEUTSCH® connector	female	(-) ground	X	356-3701

<sup>1)</sup> Only for use with MIC3/3+, MIC4 and MIC5 ignition controllers.

#### For CATERPILLAR® G3400/C & G3500/B Series Gas Engines (CSA Applications)

P/N	Color	Primary Termination	HV Termination	Polarity	MOST	Equivalent to
06.50.142	white	DEUTSCH® connector	female	(-) ground	not applicable	232-6349, 165-1592, 122-8070
06.50.146 <sup>1)</sup>	white	DEUTSCH® connector	female	(-) ground	X	232-6349, 165-1592, 122-8070
06.50.144	white	DEUTSCH® connector	female	(-) ground	not applicable	232-6353, 213-7444
06.50.148 <sup>1)</sup>	white	DEUTSCH® connector	female	(-) ground	X	232-6353, 213-7444
06.50.152	white	DEUTSCH® connector	female	(-) ground	not applicable	437-4047, 232-6347, 165-1590
06.50.156 <sup>1)</sup>	white	DEUTSCH® connector	female	(-) ground	X	437-4047, 232-6347, 165-1590
06.50.154	white	DEUTSCH® connector	female	(-) ground	not applicable	418-4862, 259-2078
06.50.158 <sup>1)</sup>	white	DEUTSCH® connector	female	(-) ground	X	418-4862, 259-2078

<sup>1)</sup> Only for use with MIC3/3+, MIC4 and MIC5 ignition controllers.

Please see page 34 and 88 for suitable ignition coil extensions and extension overhaul kits.



# Ignition Coils



Ignition Systems

For CATERPILLAR® G3500C/E & G3600 Series Gas Engines with Ignition Coil Extension

P/N	Figure	Supersedes	Color	Primary Termination	HV Termination	Polarity	MOST	Equivalent to
06.50.164	1	06.50.161	white	MIL, 3 pole, pin	female	(-) ground	not applicable	438-5682, 310-3180, 283-5269, 232-6351, 191-9346
06.50.165 <sup>1)</sup>	1	06.50.162	white	MIL, 3 pole, pin	female	(-) ground	X	438-5682, 310-3180, 283-5269, 232-6351, 191-9346

<sup>1)</sup> Only for use with MIC3/3+, MIC4 and MIC5 ignition controllers.

For CATERPILLAR® GCM34 Series Gas Engines with Ignition Coil Extension

P/N	Figure	Supersedes	Color	Primary Termination	HV Termination	Polarity	MOST	Equivalent to
06.50.174	2	06.50.170	white	MIL, 3 pole, pin	female	(-) ground	not applicable	193-468157, 258-4893
06.50.175 <sup>1)</sup>	2		white	MIL, 3 pole, pin	female	(-) ground	X	193-468157, 258-4893

<sup>1)</sup> Only for use with MIC3/3+, MIC4 and MIC5 ignition controllers.

For PERKINS® 4016-E61TRS Gas Engines

P/N	Figure	Supersedes	Color	Primary Termination	HV Termination	Polarity	MOST	Equivalent to
06.50.111	3		white	DEUTSCH® connector	female	(-) ground	not applicable	837/9, 10000-06176





# Ignition Coils

UNSHIELDED

Ignition Coil for WÄRTSILÄ® Gas Engines

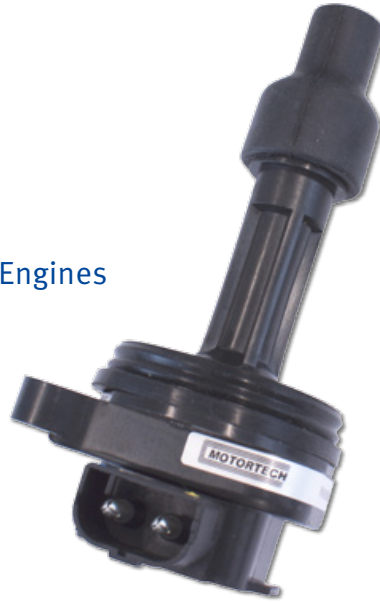

For WÄRTSILÄ® 25SG, 28SG and 220G/SG Gas Engines

P/N	Color	Primary Termination	HV Termination	Polarity	MOST	Equivalent to
06.50.059	black	2 pole, pin	female	(-) ground	not applicable	1469-008



## Ignition Coil Conversion Kits for CUMMINS® Gas Engines

For CUMMINS® gas engines series QSK60G and QSV81/91G, MOTORTECH designed special ignition coil conversion kits which allow an easy, fast and cost effective conversion to the latest MOTORTECH equipment.



- For CUMMINS® gas engines QSK60G and QSV81G/ QSV91G
- Easy and fast conversion (plug & play) of existing OEM ignition coil
- Cost effective solution
- For unshielded applications (non CSA)

### 1 Ignition Coil

- MOTORTECH ignition coil with specific flange
- Pressure proof metal housing
- Diagnostic interface (BNC connector) for easy monitoring of high voltage traces via MOTORTECH SparkView or digital oscilloscope

### 2 Adaptor Flange

### 3 Engine specific PolyMot™ Spark Plug Extension

- High quality TEFLON® for long life
- Special top thread for easy removal with MOTORTECH removal tool (P/N 44.99.912)
- Built in 5 kOhm resistor for RFI suppression
- Internal silicon seal for spark plug insulator

### 4 Fastening Material



P/N	Description	Quantity	Equivalent to
75.30.143	Ignition coil conversion kit for CUMMINS® QSK60G <i>Contains:</i> <ul style="list-style-type: none"> <li>• Flange ignition coil with diagnostic interface and integrated primary lead</li> <li>• Adaptor flange with fastening material</li> <li>• PolyMot™ spark plug extension</li> </ul>	1 pc. 1 pc. 1 pc.	2881124, 4011615
75.30.144	Ignition coil conversion kit for CUMMINS® QSV81G/QSV91G <i>Contains:</i> <ul style="list-style-type: none"> <li>• Flange ignition coil with diagnostic interface and integrated primary lead</li> <li>• Adaptor flange with fastening material</li> <li>• PolyMot™ spark plug extension</li> </ul>	1 pc. 1 pc. 1 pc.	2881124, 4011615

# Ignition Coils

## Ignition Coil Extensions

For **MOTORTECH/CATERPILLAR®** Ignition Coils – For CATERPILLAR® G3500C/E and G3600 Series Gas Engines

P/N	Figure	Description	Application	Resistance	Extension Length	Extension Diameter	Fits Ignition Coil P/N	Equivalent to
06.80.459H <sup>1)</sup>	<b>1</b>	Ignition coil extension	G3500C/E, G3600	0 kΩ	248 mm	26 mm	06.50.161, 06.50.162, 283-5270	308-1380, 283-5271, 264-5323, 150-2050
06.80.600	<b>2</b>	Ignition coil extension	G3500C/E, G3600	0 kΩ	252 mm	26 mm	06.50.164, 06.50.165	

<sup>1)</sup> Supersedes ignition coil extensions P/N 06.80.375H and 06.80.446H.

For **MOTORTECH/CATERPILLAR®** Ignition Coils – For CATERPILLAR® GCM34 Series Gas Engines

P/N	Figure	Description	Application	Resistance	Extension Length	Extension Diameter	Fits Ignition Coil P/N	Equivalent to
06.80.1013-T	<b>3</b>	Ignition coil extension	GCM34	5 kΩ	530 mm	26 mm	193-468157, 258-4893, 06.50.170	263210167, 3400.7-21.07.02-03
06.80.602	<b>4</b>	Ignition coil extension	GCM34	5 kΩ	534 mm	26 mm	06.50.174, 06.50.175	

For **WÄRTSILÄ®** 34SG and 220G/SG Gas Engines

P/N	Description	Application	Resistance	Extension Length	Extension Diameter	Fits Ignition Coil P/N	Equivalent to
06.80.460	Ignition coil extension	34SG series	5 kΩ	460 mm	26 mm		0012E002200
06.80.461	Ignition coil extension	34SG series	5 kΩ	446 mm	26 mm		0012E006500
06.80.145-1	Ignition coil extension	220G/SG series	5 kΩ	334 mm	24 mm		3340063
06.80.145-2	Ignition coil extension	220G/SG series	5 kΩ	329 mm	24 mm		3341380



## Ignition Coil Extension Overhaul Kits

Kits for **MOTORTECH** Ignition Coils – For CATERPILLAR® G3400/C and G3500/B Series Gas Engines

P/N	Figure	Supersedes	Description	Application	Extension Length	Extension Diameter	Fits Ignition Coil P/N
06.80.741	5		Extension overhaul kit	G3400 – Non CSA	95 mm	30 mm	06.50.141, 06.50.145
06.80.742	5		Extension overhaul kit	G3400 – CSA	97 mm	30 mm	06.50.142, 06.50.146
06.80.743	5		Extension overhaul kit	G3400 – Non CSA	107 mm	30 mm	06.50.143, 06.50.147
06.80.744	5		Extension overhaul kit	G3400 – CSA	109 mm	30 mm	06.50.144, 06.50.148
06.80.751	5		Extension overhaul kit	G3500 – Non CSA	118 mm	30 mm	06.50.151, 06.50.155
06.80.752	5		Extension overhaul kit	G3500 – CSA	105 mm	30 mm	06.50.152, 06.50.156
06.80.753	5		Extension overhaul kit	G3500 – Non CSA	112 mm	30 mm	06.50.153, 06.50.157
06.80.754	5		Extension overhaul kit	G3500 – CSA	105 mm	30 mm	06.50.154, 06.50.158

Kits for **CATERPILLAR**® Ignition Coils – For CATERPILLAR® G3400/C and G3500/B Series Gas Engines

P/N	Figure	Supersedes	Description	Application	Extension Length	Extension Diameter	Fits Ignition Coil P/N
06.80.419H	5		Extension overhaul kit	G3400 – Non CSA	95 mm	30 mm	232-6348, 165-1591, 131-3277, 129-8802, 108-0615
06.80.742	5	06.80.418H	Extension overhaul kit	G3400 – CSA	97 mm	30 mm	232-6349, 165-1592, 122-8070
06.80.420H	5		Extension overhaul kit	G3400 – Non CSA	107 mm	30 mm	232-6352, 213-7443
06.80.744	5	06.80.417H	Extension overhaul kit	G3400 – CSA	109 mm	30 mm	232-6353, 213-7444
06.80.515H	5	06.80.315H	Extension overhaul kit	G3500 – Non CSA	118 mm	30 mm	232-6346, 165-1589, 124-0749
06.80.752	5	06.80.415H	Extension overhaul kit	G3500 – CSA	105 mm	30 mm	232-6347, 165-1590
06.80.480	5		Extension overhaul kit	G3500 – Non CSA	112 mm	30 mm	232-6350
06.80.754	5	06.80.415H	Extension overhaul kit	G3500 – CSA	105 mm	30 mm	259-2078



5

# Ignition Coils

## Accessories for Unshielded Ignition Coils

Different ignition coil styles require different boots to seal the primary or secondary terminals. MOTORTECH boots are all made from highest grade of silicone (482 °F / 250 °C).

The boots will remain soft and flexible over a long time and protect the operator from touching any low or high voltage terminations. The boots also ensure that the critical areas stay clean and dry even in the worst environment.

### Boots for MOTORTECH Ignition Coils

P/N	Figure	Ignition Coil Side		Outlet		Ignition Coil 06.50. ...															
		Primary	Secondary	90°	180°	003	053	054	055	060	065	100	102	103	104	105	112	113	300	301	
06.80.037	1	x		x		x	x	x	x	x	x										
06.84.082	2	x		x								x	x		x	x	x	x	x	x	x
06.84.021	3	x		x										x <sup>1)</sup>							
06.80.005	4	x			x	x	x	x	x	x	x										
06.84.083	5		x	x								x			x		x			x	
06.80.006	6		x		x	x				x											
06.84.006	7		x		x		x	x	x		x		x			x		x			x

<sup>1)</sup> Two boots needed for each ignition coil.



### Boots for ALTRONIC® Ignition Coils

P/N	Figure	Ignition Coil Side		Outlet		Ignition Coil
		Primary	Secondary	90°	180°	
06.80.037	1	x		x		291001, 591010, 501061
06.80.036	2	x			x	291001, 591010, 501061
06.84.006	3		x		x	291001, 591010, 501061



## Secondary Connections

P/N	Figure	Description	Ignition Coil 06.50. ...														
			003	053	054	055	060	065	100	102	103	104	105	112	113	300	301
06.80.261		Coil terminal, 180°, requires P/N 06.80.126		x	x	x		x		x			x		x		x
06.80.091		Coil terminal, 180°, requires P/N 06.80.126								x <sup>1)</sup>		x	x <sup>1)</sup>		x <sup>1)</sup>		x <sup>1)</sup>
06.80.108		Crimp terminal base	x				x		x			x		x		x	
06.80.116		Crimp terminal, 90°, requires P/N 06.80.108	x				x										
06.80.116-180		Crimp terminal, 180°, requires P/N 06.80.108								x			x			x	
06.80.126		Crimp terminal base		x	x	x		x	x <sup>1)</sup>	x	x	x <sup>1)</sup>	x	x <sup>1)</sup>	x	x <sup>1)</sup>	x
06.84.024		Coil terminal, 90°, including terminal P/N 02.85.920										x					
06.84.025		Coil terminal, 180°, including terminal P/N 02.85.920										x					
22.80.009		Coil terminal, 90°, 1 kΩ resistor, requires P/N 06.80.126									x		x		x		x

<sup>1)</sup> When using SAE contact pin P/N 06.51.223.



## Accessories

P/N	Figure	Description	Ignition Coil 06.50. ...														
			003	053	054	055	060	065	100	102	103	104	105	112	113	300	301
06.51.223		SAE contact pin								x			x		x		x
06.90.264 <sup>1)</sup>		Accessory kit incl. fastening screws and nuts								x	x		x	x	x	x	x
02.85.1012		SAE spreading adaptor		x	x	x		x		x			x		x		x

<sup>1)</sup> Comes with each New MOTORTECH Style ignition coil.



# Ignition Coils

**SHIELDED**

## Flange Ignition Coils

MOTORTECH makes available the BLUE and RED flanged ignition coil as a replacement for the existing products sold by ALTRONIC® and the engine manufacturers.

Specially designed versions for use with newest technologies of MOTORTECH ignitions controllers are also available:

- MOST – MOTORTECH Output Stage Technology of MOTORTECH MIC3/3+, MIC4, MIC5 and MIC6 ignition controllers



### 3 Pole Primary Connector Arrangement



P/N	Color	Primary Termination	HV Termination	Polarity	MOST	Equivalent to
06.50.034	red	MIL, 3 pole, pin	female	(-) ground	not applicable	591012, 69694F, 7W-4377
06.50.035	blue	MIL, 3 pole, pin	female	(-) ground	not applicable	591018, 69694G A69694G
06.50.036	red	MIL, 3 pole, pin	female	(-) ground	x	
95.09.100	steel	MIL, 3 pole, pin	female	(-) ground	x	
95.09.133	steel	MIL, 3 pole, pin	female	(+) ground	not applicable	
95.09.134	steel	MIL, 3 pole, pin	female	(-) ground	not applicable	591012, 69694F, 7W-4377
95.09.135	steel	MIL, 3 pole, pin	female	(-) ground	not applicable	591018, 69694G A69694G

# Ignition Coils



## Flange Ignition Coils with integrated Primary Lead

Based on its known flange ignition coils, MOTORTECH offers a series with integrated primary leads. Different configurations with 90-degree and 180-degree 2 pole and 3 pole connectors are available to connect the ignition coil directly to a wiring rail or to replace OEM parts in the field.



**SHIELDED**

Ignition Systems



### 2 Pole Primary Connector Arrangement – For use with AlphaRail Wiring Rails



P/N <sup>1)</sup>	Color	Wiring Rail Connector	HV Termination	Polarity	MOST	Equivalent to
06.50.034-L-C	red	MIL, 2 pole, pin, 180°	female	(-) ground	not applicable	
06.50.034-L-D	red	MIL, 2 pole, pin, 90°	female	(-) ground	not applicable	
06.50.035-L-C	blue	MIL, 2 pole, pin, 180°	female	(-) ground	not applicable	
06.50.035-L-D	blue	MIL, 2 pole, pin, 90°	female	(-) ground	not applicable	
06.50.036-L-C	red	MIL, 2 pole, pin, 180°	female	(-) ground	X	
06.50.036-L-D	red	MIL, 2 pole, pin, 90°	female	(-) ground	X	

<sup>1)</sup> Standard primary lead lengths (“-L-”) = 12 in., 18 in., 24 in., 30 in., 36 in., 42 in. Other lengths available on request.

### For use with WAUKESHA® ESM Gas Engines



P/N	Color	Primary Lead Length	Wiring Rail Connector	HV Termination	Polarity	MOST	Equivalent to
06.50.035-30-A	blue	30 in.	3 pole, socket, 180°	female	(-) ground	not applicable	
06.50.035-36-E	blue	36 in.	MIL, 3 pole, pin, 180°	female	(-) ground	not applicable	69957, 69957A



# Ignition Coils

SHIELDED



## Flange Ignition Coils with Diagnostic Interface

These MOTORTECH ignition coils are designed for operators who want to monitor their high voltage traces in a simple way. Measuring high voltage peak (kV) and spark duration ( $\mu\text{sec}$ ) of all cylinders of an engine with flange ignition coils regularly, will allow easy maintenance of the equipment.

With a MOTORTECH SparkView or digital Scope Meter the operator can receive real time data.



### 3 Pole Primary Connector Arrangement



P/N	Color	Primary Termination	HV Termination	Polarity	MOST	Equivalent to
95.09.150 <sup>1)</sup>	steel	MIL, 3 pole, pin	female	(-) ground	X	06.50.036, 95.09.100
95.09.153 <sup>2)</sup>	steel	MIL, 3 pole, pin	female	(+) ground	not applicable	95.09.133
95.09.154 <sup>3)</sup>	steel	MIL, 3 pole, pin	female	(-) ground	not applicable	591012, 69694F, 7W-4377, 06.50.034, 95.09.134
95.09.155 <sup>4)</sup>	steel	MIL, 3 pole, pin	female	(-) ground	not applicable	591018, 69694G, A69694G, 06.50.035, 95.09.135

<sup>1)</sup> Same coil winding as P/N 06.50.036 and 95.09.100, but with diagnostic interface.

<sup>2)</sup> Same coil winding as P/N 95.09.133, but with diagnostic interface.

<sup>3)</sup> Same coil winding as P/N 06.50.034 and 95.09.134, but with diagnostic interface. Thus also equivalent to P/N 591012, 69694F and 7W-4377.

<sup>4)</sup> Same coil winding as P/N 06.50.035 and 95.09.135, but with diagnostic interface. Thus also equivalent to P/N 591018, 69694G and A69694G.



Additional BNC connector for high voltage measurement

## SparkView

MOTORTECH HIGH VOLTAGE INDICATOR

The SparkView is a handheld device developed by MOTORTECH that can monitor the high voltage required by the spark plug while the engine is running. With a measuring clamp or cable and the display for up to 40 kV, it is easy to determine the condition of the spark plugs and the time at which they need to be replaced.



See page 110.

# Ignition Coils



## Flange Ignition Coils with Diagnostic Interface and integrated Primary Lead

MOTORTECH flange ignition coils with diagnostic interface are also available with integrated primary leads. These include different connector arrangements for a direct wiring rail connection and to offer an upgrade and replacement to used OEM products.



SHIELDED

Ignition Systems



### 2 Pole Primary Connector Arrangement – For use with AlphaRail Wiring Rails



P/N <sup>1)</sup>	Color	Wiring Rail Connector	HV Termination	Polarity	MOST	Equivalent to
95.09.150-L-C	steel	MIL, 2 pole, pin, 180°	female	(-) ground	X	
95.09.150-L-D	steel	MIL, 2 pole, pin, 90°	female	(-) ground	X	
95.09.154-L-C	steel	MIL, 2 pole, pin, 180°	female	(-) ground	not applicable	
95.09.154-L-D	steel	MIL, 2 pole, pin, 90°	female	(-) ground	not applicable	
95.09.155-L-C	steel	MIL, 2 pole, pin, 180°	female	(-) ground	not applicable	
95.09.155-L-D	steel	MIL, 2 pole, pin, 90°	female	(-) ground	not applicable	

### For use with WAUKESHA® ESM Gas Engines



P/N	Color	Primary Lead Length	Wiring Rail Connector	HV Termination	Polarity	MOST	Equivalent to
95.09.155-30-A <sup>1)</sup>	steel	30 in.	3 pole, socket, 180°	female	(-) ground	not applicable	
95.09.155-36-E <sup>1)</sup>	steel	36 in.	MIL, 3 pole, pin, 180°	female	(-) ground	not applicable	6995, 69957A

<sup>1)</sup> Same coil winding as P/N 06.50.035-30-A and 06.50.035-36-E, but with diagnostic interface.

### For use with CUMMINS® QSK60G and QSV81/91G Gas Engines

P/N	Color	Primary Lead Length	Wiring Rail Connector	HV Termination	Polarity	MOST	Equivalent to
95.09.156-20-B <sup>1)</sup>	steel	20 in.	3 pole, socket, 180°	female	(-) ground	X	

<sup>1)</sup> Use of ignition coil only possible, if conversion kits P/N 75.30.143 or 75.30.144 previously were used.

# Ignition Coils

## Spark Plug Carrier and Flange Adaptor Hardware Kit for WAUKESHA® VHP-GL Engines – CSA® Conversion

- For modification of standard ignition coil to flange ignition coil arrangement
- Available as single parts
- Inventory item

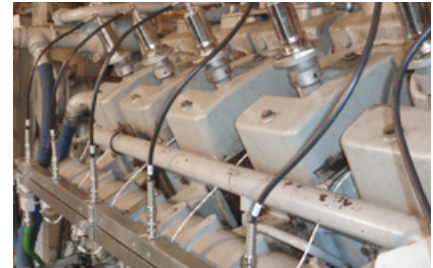
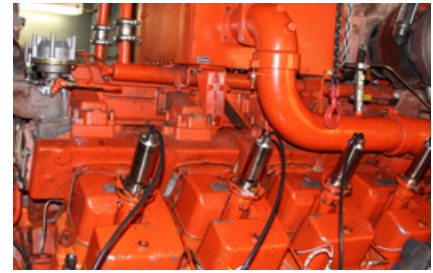

### A Primary Lead

P/N	Description	Equivalent to	Required Qty. per Cylinder
95.01.020-30	Primary lead, Conventional Style, 3 pole ignition coil connector, 1/2-14 NPT outlet box adaptor	208503K, 593027-30	1
alternative 95.01.120-30	Primary lead, New Flex Style, 3 pole ignition coil connector, 1/2-14 NPT outlet box adaptor	95.01.020-30	1

### B Flange Ignition Coil

P/N	Description	Equivalent to	Required Qty. per Cylinder
06.50.035	Flange ignition coil	A69694G, 69694G, 591018	1
alternative 95.09.155 <sup>1)</sup>	Flange ignition coil with diagnostic interface	A69694G, 69694G, 591018	1

<sup>1)</sup> Same coil winding as P/N 06.50.035, but with diagnostic interface. Thus also equivalent to P/N 591018 and 69694G, A69694G.

### C PolyMot™ Spark Plug Extension

P/N	Description	Equivalent to	Required Qty. per Cylinder
06.80.321-T	PolyMot spark plug extension	A211797H, A211797P, 211357P, 211357U, A211797R	1

### D Spark Plug

P/N	Description	Equivalent to	Required Qty. per Cylinder
FB77WPC	CHAMPION® spark plug, M18x1.5, reach 0.750 in., J-type Ir/Ir, HEX 7/8 in. (22.2 mm)	69919, 60999T	1
alternative B8324	MOTORTECH MHP spark plug, M18x1.5, reach 0.750 in., J-type Ir/Ir, HEX 13/16 in. (20.8 mm)		1
alternative GI3-3	DENSO® spark plug, M18x1.5, reach 0.750 in., J-type Ir/Pt, HEX 7/8 in. (22.2 mm)		1



**SparkView**  
MOTORTECH HIGH VOLTAGE INDICATOR

The SparkView is a handheld device developed by MOTORTECH that can monitor the high voltage required by the spark plug while the engine is running. With a measuring clamp or cable and the display for up to 40 kV, it is easy to determine the condition of the spark plugs and the time at which they need to be replaced.

# Ignition Coils

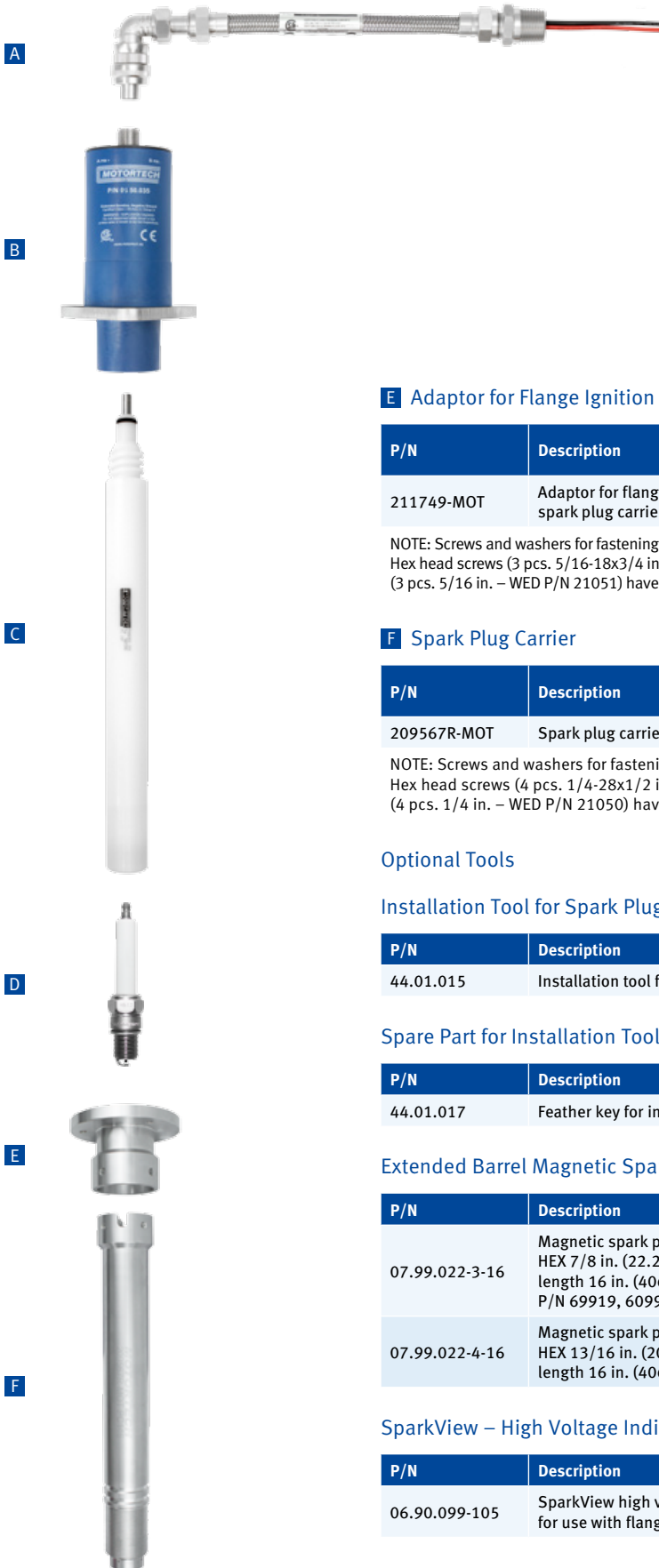

## E Adaptor for Flange Ignition Coil/Spark Plug Carrier

P/N	Description	Equivalent to	Required Qty. per Cylinder
211749-MOT	Adaptor for flange ignition coil/spark plug carrier	211749	1

NOTE: Screws and washers for fastening of flange ignition coil not included. Hex head screws (3 pcs. 5/16-18x3/4 in – WED P/N 21309) and washers (3 pcs. 5/16 in. – WED P/N 21051) have to be supplied by customer.

## F Spark Plug Carrier

P/N	Description	Equivalent to	Required Qty. per Cylinder
209567R-MOT	Spark plug carrier	209567R	1

NOTE: Screws and washers for fastening of flange adaptor not included. Hex head screws (4 pcs. 1/4-28x1/2 in – WED P/N 21296) and lock washers (4 pcs. 1/4 in. – WED P/N 21050) have to be supplied by customer.

## Optional Tools

### Installation Tool for Spark Plug Carrier

P/N	Description
44.01.015	Installation tool for spark plug carrier

### Spare Part for Installation Tool

P/N	Description
44.01.017	Feather key for installation tool

### Extended Barrel Magnetic Spark Plug Sockets

P/N	Description
07.99.022-3-16	Magnetic spark plug socket, HEX 7/8 in. (22.2 mm), 1/2 in. drive, length 16 in. (406.4 mm), for use with spark plugs P/N 69919, 60999T, FB77WPCC, G13-3
07.99.022-4-16	Magnetic spark plug socket, HEX 13/16 in. (20.8 mm), 1/2 in. drive, length 16 in. (406.4 mm), for use with spark plug P/N B8324

### SparkView – High Voltage Indicator

P/N	Description
06.90.099-105	SparkView high voltage indicator – incl. BNC cable P/N 06.90.105, for use with flange ignition coils with diagnostic interface

# Ignition Coils

## SHIELDED

### Externally Mounted Ignition Coils

Shielded – externally mounted – ignition coils are encapsulated in a steel housing with welded lids. A bracket is used to install the coils on a wiring rail or directly on the engine. This type of ignition coil is connected to the spark plug by a shielded spark plug lead with a 3/4 in. or 1 in. termination. Primary voltage connection is made by a 2 or 3 pole military style screw connector. All parts meet the CSA Class I, Division 2, Group C/D.

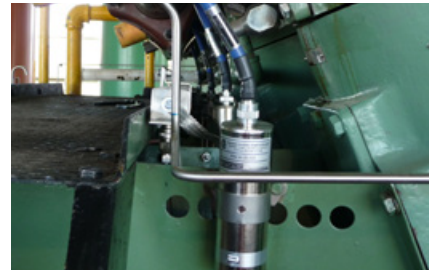

### 3 Pole Primary Connector Arrangement



P/N	Supersedes	Color	Primary Termination	HV Termination	Polarity	MOST	Equivalent to
95.09.005		steel	MIL, 3 pole, pin	3/4-20 UNEF	(-) ground	X	
95.09.053	95.09.001	steel	MIL, 3 pole, pin	3/4-20 UNEF	(+) ground	not applicable	291001-S
95.09.054	95.09.003	steel	MIL, 3 pole, pin	3/4-20 UNEF	(-) ground	not applicable	591010-S
95.09.055	95.09.002	steel	MIL, 3 pole, pin	3/4-20 UNEF	(-) ground	not applicable	501061-S, 2881178

### 2 Pole Primary Connector Arrangement



P/N	Supersedes	Color	Primary Termination	HV Termination	Polarity	MOST	Equivalent to
95.08.003	95.08.001, 95.08.002	steel	MIL, 2 pole, pin	1-20 UNEF	(-) ground	X	PPT2477AD, PPT2477ADL
95.08.005		steel	MIL, 2 pole, pin	3/4-20 UNEF	(+) ground	not applicable	10-382040-1



# Ignition Coils



**SHIELDED**

Ignition Systems

## Externally Mounted Ignition Coils with Diagnostic Interface

These MOTORTECH ignition coils are designed for operators who want to monitor their high voltage traces in a simple way. Measuring high voltage peak (kV) and spark duration (µsec) of all cylinders of an engine with externally mounted ignition coils regularly, will allow easy maintenance of the equipment.

With a MOTORTECH SparkView or digital Scope Meter the operator can receive real time data.



### 3 Pole Primary Connector Arrangement

P/N	Supersedes	Color	Primary Termination	HV Termination	Polarity	MOST	Equivalent to
95.09.070 <sup>1)</sup>		steel	MIL, 3 pole, pin	3/4-20 UNEF	(-) ground	X	95.09.005
95.09.073 <sup>2)</sup>		steel	MIL, 3 pole, pin	3/4-20 UNEF	(+) ground	not applicable	291001-S, 95.09.053
95.09.074 <sup>3)</sup>		steel	MIL, 3 pole, pin	3/4-20 UNEF	(-) ground	not applicable	591010-S, 95.09.054
95.09.075 <sup>4)</sup>		steel	MIL, 3 pole, pin	3/4-20 UNEF	(-) ground	not applicable	501061-S, 2881178, 95.09.055

<sup>1)</sup> Same coil winding as P/N 95.09.005, but with diagnostic interface.

<sup>2)</sup> Same coil winding as P/N 95.09.053, but with diagnostic interface. Thus also equivalent to P/N 291001-S.

<sup>3)</sup> Same coil winding as P/N 95.09.054, but with diagnostic interface. Thus also equivalent to P/N 591010-S.

<sup>4)</sup> Same coil winding as P/N 95.09.055, but with diagnostic interface. Thus also equivalent to P/N 501061-S and 2881178.

### 2 Pole Primary Connector Arrangement



P/N	Supersedes	Color	Primary Termination	HV Termination	Polarity	MOST	Equivalent to
95.08.070 <sup>1)</sup>		steel	MIL, 2 pole, pin	1-20 UNEF	(-) ground	X	PPT2477AD, PPT2477ADL, 95.08.003

<sup>1)</sup> Same coil winding as P/N 95.08.003, but with diagnostic interface. Thus also equivalent to P/N PPT2477AD and PPT2477ADL.

Additional BNC connector for high voltage measurement



## SparkView MOTORTECH HIGH VOLTAGE INDICATOR

The SparkView is a handheld device developed by MOTORTECH that can monitor the high voltage required by the spark plug while the engine is running. With a measuring clamp or cable and the display for up to 40 kV, it is easy to determine the condition of the spark plugs and the time at which they need to be replaced.



See page 110.

# Ignition Coils

**SHIELDED**

## Integral Ignition Coils – Slim Design

Integral ignition coils are mostly used in shielded applications and are designed to be mounted directly on a dual threaded spark plug. This design does not require a spark plug lead. The ignition coil life is affected by the temperature that is transferred into the coil by the spark plug. On occasions where the spark plug leaks, high combustion pressure enters the ignition coil and forces the base coil to blow out of its housing. MOTORTECH's design with a new top cover and a modern production process will not allow this to happen.

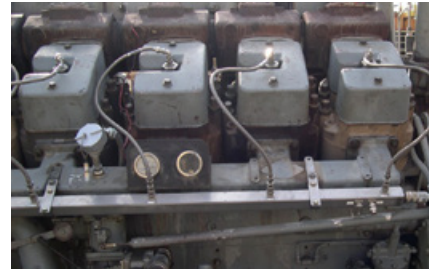

Top cover with integrated HEX for easy installation/deinstallation



### 3 Pole Primary Connector Arrangement – ALTRONIC® Compatible



P/N <sup>1)</sup>	Supersedes	Color	Length	Primary Termination	HV Termination		Polarity	MOST	Equivalent to
					Outer Thread	Inner Thread			
95.09.222-6 <sup>2)</sup>	95.09.012-6, 95.09.040-6, 95.09.022-6	steel	6.00 in.	MIL, 3 pole, pin		13/16-20 UNEF	(-) ground	not applicable	591011A, 107-2400
95.09.222-12 <sup>2)</sup>	95.09.012-12, 95.09.040-12, 95.09.022-12	steel	12.00 in.	MIL, 3 pole, pin		13/16-20 UNEF	(-) ground	not applicable	591011B, 591011C, 215-2434, 69694D
95.09.223-6 <sup>2)</sup>	95.09.010, 95.09.030, 95.09.023-6	steel	6.00 in.	MIL, 3 pole, pin	1-20 UNEF	13/16-20 UNEF	(-) ground	not applicable	591007, 4W-4959, 60615F
95.09.233-6 <sup>3)</sup>	95.09.011, 95.09.031, 95.09.033-6	steel	6.00 in.	MIL, 3 pole, pin	1-20 UNEF	13/16-20 UNEF	(+) ground	not applicable	591008

<sup>1)</sup> Ignition coils in 10 in. only available on special request.

<sup>2)</sup> For use with MIC500, ALT I, ALT III, ALT V, CD200, CD200D, DISN, CPU90, CPU95, CEC, CATERPILLAR® (163-6164, 163-610®).

<sup>3)</sup> For use with ALT II, DIS, CPU2000.

### 2 Pole Primary Connector Arrangement – FAIRBANKS MORSE® Style



P/N <sup>1)</sup>	Supersedes	Color	Length	Primary Termination	HV Termination		Polarity	MOST	Equivalent to
					Outer Thread	Inner Thread			
95.08.022-6 <sup>2)</sup>	95.08.010-6, 95.08.030-6	steel	6.00 in.	MIL, 2 pole, pin		13/16-20 UNEF	(-) ground	not applicable	PPT2477AA6
95.08.022-12 <sup>2)</sup>	95.08.010-12, 95.08.030-12	steel	12.00 in.	MIL, 2 pole, pin		13/16-20 UNEF	(-) ground	not applicable	PPT2477AA12

<sup>1)</sup> Ignition coils in 8 in. (PPT2477AA8) and 10 in. (PPT2477AA10) only available on special request.

<sup>2)</sup> For use with MIC500, MIC850.

Conversion: 1 inch = 25,4 mm / 1 foot = 0,3 m



## Integral Ignition Coils – Fat Design

For slow and mid speed engines it is favorable to have more spark energy available. MOTORTECH offers a full line of special and more powerful integral ignition coils with a proven design including different lengths and versions for use with MOTORTECH MIC3/3+, MIC4, MIC5, MIC500 and MIC850 series ignition controllers (support MOST and ASC technology) to meet the application and spark plug requirement.



Top cover with integrated HEX for easy installation/deinstallation



### 3 Pole Primary Connector Arrangement – MIC3/3+, MIC4, MIC5 Compatible – MOST



P/N <sup>1)</sup>	Supersedes	Color	Length	Primary Termination	HV Termination		Polarity	MOST	Equivalent to
					Outer Thread	Inner Thread			
95.09.142-11 <sup>2)</sup>	95.09.060-11	steel	11.00 in.	MIL, 3 pole, pin		13/16-20 UNEF	(-) ground	X	
95.09.143-6 <sup>2)</sup>	95.09.013-6, 95.09.050-6	steel	6.00 in.	MIL, 3 pole, pin	1-20 UNEF	13/16-20 UNEF	(-) ground	X	

<sup>1)</sup> Ignition coils in 12 in. and 14.5 in. only available on special request.

<sup>2)</sup> For use with MIC3/3+, MIC4, MIC5, MIC500, MIC850. P/N 95.09.142-11 for use on WAUKESHA® VHP-GSI with rain shield.

For existing installations with **ALTRONIC®** ignition controllers, MOTORTECH offers a special series of high energy integral ignition coils with 3 pole primary connector.

The ignition coils are designed to have the electrical characteristics to function with the **ALTRONIC®** patented “Spark Reference” high voltage indication system.

### 3 Pole Primary Connector Arrangement – ALTRONIC® Compatible



P/N <sup>1)</sup>	Supersedes	Color	Length	Primary Termination	HV Termination		Polarity	MOST	Equivalent to
					Outer Thread	Inner Thread			
95.09.122-11 <sup>2)</sup>	95.09.061-11	steel	11.00 in.	MIL, 3 pole, pin		13/16-20 UNEF	(-) ground	not applicable	
95.09.123-6 <sup>2)</sup>	95.09.051-6	steel	6.00 in.	MIL, 3 pole, pin	1-20 UNEF	13/16-20 UNEF	(-) ground	not applicable	

<sup>1)</sup> Ignition coils in 12 in. and 14.5 in. only available on special request.

<sup>2)</sup> For use with MIC500, ALT I, ALT III, ALT V, CD200, CD200D, DISN, CPU90, CPU95, CEC. P/N 95.09.122-11 for use on WAUKESHA® VHP-GSI with rain shield.

MOTORTECH high energy integral ignition coils are also available with 2 pole primary connector for use with MOTORTECH MIC3/3+, MIC4, MIC5, MIC500 and MIC850

(includes support of ASC and MOST feature) series ignition controllers.

### 2 Pole Primary Connector Arrangement – FAIRBANKS MORSE® Style – MOST



P/N <sup>1)</sup>	Supersedes	Color	Length	Primary Termination	HV Termination		Polarity	MOST	Equivalent to
					Outer Thread	Inner Thread			
95.08.142-11 <sup>2)</sup>	95.08.050-11	steel	11.00 in.	MIL, 2 pole, pin		13/16-20 UNEF	(-) ground	X	
95.08.143-6 <sup>2)</sup>	95.08.020-6, 95.08.040-6	steel	6.00 in.	MIL, 2 pole, pin	1-20 UNEF	13/16-20 UNEF	(-) ground	X	PPT2477AB6

<sup>1)</sup> Ignition coils in 12 in. (PPT2477AB12) and 14.5 in. only available on special request.

<sup>2)</sup> For use with MIC3/3+, MIC4, MIC5, MIC500, MIC850. P/N 95.08.142-11 for use on WAUKESHA® VHP-GSI with rain shield.

# Ignition Coils

As an additional accessory, MOTORTECH offers suitable grommets for certain applications. Made of Teflon or silicone, these grommets perfectly fit the slim and fat design integral ignition coils and protect the spark plug well against dirt and fluids.



## Grommets for Integral Ignition Coils

P/N	Figure	Description	Material	Integral Ignition Coil Type	Engine Make and Model	Equivalent to
06.84.026	1	Grommet	Silicone	Slim Design	CATERPILLAR® G342, G379, G398, G399	9Y-3987, ICG-625
06.84.116	2	Grommet	Teflon	Slim Design	CATERPILLAR® G3300 series	106-9185
06.84.117	2	Grommet	Teflon	Slim Design	CATERPILLAR® G3400 series	9Y-7361
06.84.069	2	Grommet	Teflon	Fat Design	WAUKESHA® VHP and VGF series	



1



2



# Pickups & Trigger Drives

## UNSHIELDED

### Pickups

A wide range of standard ignition pickups are available from MOTORTECH to allow service companies and operators to select what they need to do a professional installation. High quality, designed to meet the application and temperature requirements, MOTORTECH pickups will last and ensure you are not experiencing any unexpected shut downs.

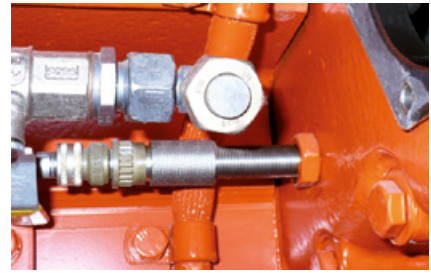

#### Magnetic Pickups – Thread Size 5/8-18 UNF <sup>1)</sup>



P/N	Figure	Supersedes	Thread Size	Thread Length	Trigger	Equivalent to
66.60.001-125	1	06.60.101	5/8-18 UNF	1.25 in.	holes, pins, teeth, screws	
66.60.001-175	1	06.60.105	5/8-18 UNF	1.75 in.	holes, pins, teeth, screws	691118-1
66.60.001-250	1	06.60.102	5/8-18 UNF	2.50 in.	holes, pins, teeth, screws	691118-2
66.60.001-400	1	06.60.103	5/8-18 UNF	4.00 in.	holes, pins, teeth, screws	691118-4
66.60.001-600	1	06.60.107	5/8-18 UNF	6.00 in.	holes, pins, teeth, screws	691118-6

<sup>1)</sup> Not for use with WAUKESHA® ESM system.

#### Hall Effect Pickups – Thread Size 5/8-18 UNF – Active Low



P/N	Figure	Supersedes	Thread Size	Thread Length	Trigger	Equivalent to
66.60.002-125	2		5/8-18 UNF	1.25 in.	magnets	
66.60.002-175	2	06.60.020	5/8-18 UNF	1.75 in.	magnets	791050-1
66.60.002-250	2	06.60.021	5/8-18 UNF	2.50 in.	magnets	791050-2
66.60.002-450	2	06.60.022	5/8-18 UNF	4.50 in.	magnets	791050-4
66.60.002-600	2		5/8-18 UNF	6.00 in.	magnets	791050-6

#### Hall Effect Pickups – Thread Size 5/8-18 UNF – Active High <sup>1)</sup>



P/N	Figure	Supersedes	Thread Size	Thread Length	Trigger	Equivalent to
66.60.012-175	2		5/8-18 UNF	1.75 in.	magnets	591014-1
66.60.012-250	2		5/8-18 UNF	2.50 in.	magnets	591014-2
66.60.012-450	2		5/8-18 UNF	4.50 in.	magnets	591014-4
66.60.012-600	2		5/8-18 UNF	6.00 in.	magnets	591014-6

<sup>1)</sup> For use with ALTRONIC® CPU90, CPU95, CPU2000 ignition controllers.

#### Inductive Pickups – Thread Size M12x1



P/N	Figure	Supersedes	Thread Size	Thread Length	Trigger	Equivalent to
66.60.003-60	3	06.60.027, 06.60.042	M12x1	60 mm	pins, screws, slots	
66.60.003-100	3	06.60.023, 06.60.040	M12x1	100 mm	pins, screws, slots	

# Pickups & Trigger Drives



SHIELDED

Ignition Systems

## Magnetic Pickups – Thread Size 5/8-18 UNF <sup>1)</sup>



P/N	Figure	Supersedes	Thread Size	Thread Length	Trigger	Equivalent to
95.70.001-125	4		5/8-18 UNF	1.25 in.	holes, pins, teeth, screws	
95.70.001-175	4		5/8-18 UNF	1.75 in.	holes, pins, teeth, screws	691118-1
95.70.001-250	4		5/8-18 UNF	2.50 in.	holes, pins, teeth, screws	691118-2
95.70.001-400	4		5/8-18 UNF	4.00 in.	holes, pins, teeth, screws	691118-4
95.70.001-600	4		5/8-18 UNF	6.00 in.	holes, pins, teeth, screws	691118-6

<sup>1)</sup> Not for use with WAUKESHA® ESM system.

## Hall Effect Pickups – Thread Size 5/8-18 UNF – Active Low



P/N	Figure	Supersedes	Thread Size	Thread Length	Trigger	Equivalent to
95.70.002-125	5		5/8-18 UNF	1.25 in.	magnets	
95.70.002-175	5		5/8-18 UNF	1.75 in.	magnets	791050-1
95.70.002-250	5		5/8-18 UNF	2.50 in.	magnets	791050-2
95.70.002-450	5		5/8-18 UNF	4.50 in.	magnets	791050-4
95.70.002-600	5		5/8-18 UNF	6.00 in.	magnets	791050-6

## Hall Effect Pickups – Thread Size 5/8-18 UNF – Active High <sup>1)</sup>



P/N	Figure	Supersedes	Thread Size	Thread Length	Trigger	Equivalent to
95.70.012-175	5		5/8-18 UNF	1.75 in.	magnets	591014-1
95.70.012-250	5		5/8-18 UNF	2.50 in.	magnets	591014-2
95.70.012-450	5		5/8-18 UNF	4.50 in.	magnets	591014-4
95.70.012-600	5		5/8-18 UNF	6.00 in.	magnets	591014-6

<sup>1)</sup> For use with ALTRONIC® CPU90, CPU95, CPU2000 ignition controllers.

## Inductive Pickups – Thread Size M12x1



P/N	Figure	Supersedes	Thread Size	Thread Length	Trigger	Equivalent to
95.70.003-60	6		M12x1	60 mm	pins, screws, slots	
95.70.003-100	6		M12x1	100 mm	pins, screws, slots	

### Legend



slots



magnets



pins



teeth



screws



holes

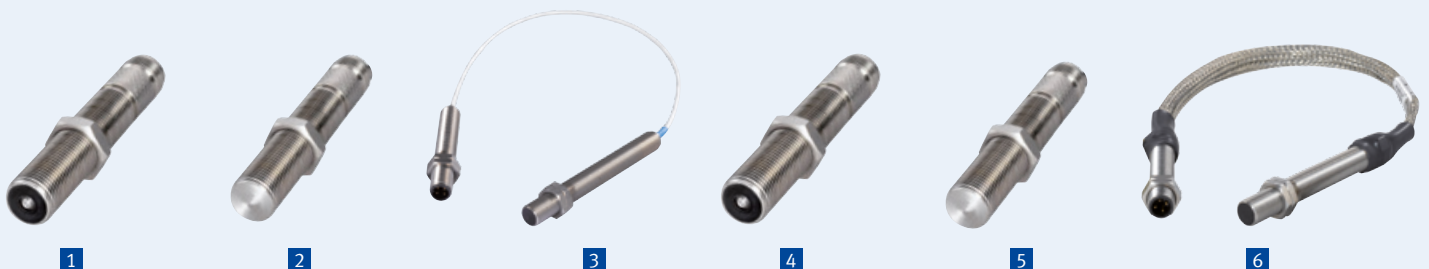

See page 60 for available pickup thread adaptors.

Conversion: 1 inch = 25,4 mm / 1 foot = 0,3 m

# Pickups & Trigger Drives

## UNSHIELDED

### Special Application Pickups

For use with competitor ignition systems, MOTORTECH offers a special series of pickups. Based on the reliable design of MOTORTECH's standard versions, this series represents a

suitable replacement for existing competitor pickups in the field.

#### Magnetic Pickups – Thread Size 3/4-16 UNF <sup>1)</sup>



P/N	Figure	Supersedes	Thread Size	Thread Length	Trigger	Equivalent to
66.60.011-180	1		3/4-16 UNF	1.80 in.	holes, pins, teeth, screws	791015-1
66.60.011-340	1		3/4-16 UNF	3.40 in.	holes, pins, teeth, screws	791016-2

<sup>1)</sup> For use with ALTRONIC® CD1, CD200, CD200D and CD200EVS ignition controllers.

#### Magnetic Pickup – Thread Size M12x1 <sup>1)</sup>



P/N	Figure	Supersedes	Thread Size	Thread Length	Trigger	Equivalent to
66.60.021-300	2		M12x1	3.00 in.	holes, pins, teeth, screws	791041-3, 10.362-1, 600-00-111-00

<sup>1)</sup> For use with ALTRONIC® CD200, CD200D and CD200EVS ignition controllers.

#### Active Pickup – Thread Size M12x1 <sup>1)</sup>



P/N	Figure	Supersedes	Thread Size	Thread Length	Trigger	Equivalent to
66.60.023-450	3		M18x1	4.50 in.	magnets	791037-4, 1229 9989

<sup>1)</sup> For use with MWM®/DEUTZ® gas engines.

#### Pickup Coil for ALTRONIC® I Magneto Ignition System

P/N	Figure	Supersedes	Connector	Lead Length	Trigger	Equivalent to
101181-MOT	4		MIL, 3 pole, socket, 180°	180.00 in. (blue 200 in.)	magnets	101181

#### Legend



slots



magnets



pins



teeth



screws



holes

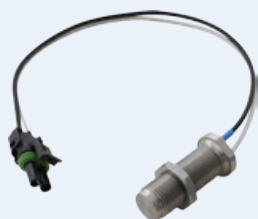

1



2



3

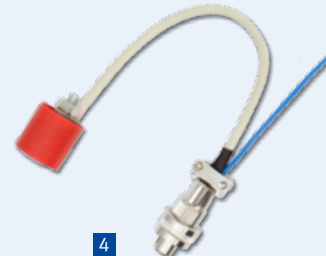

4

Conversion: 1 inch = 25,4 mm/1 foot = 0,3 m

# Pickups & Trigger Drives



UNSHIELDED

## Pickup Leads

The reliability of an electronic ignition system comes with its accessories. Every pickup needs a lead to connect to the ignition controller and ensure that the signal is transmitted without any malfunctions. MOTORTECH offers high grade

pickup leads that are all shielded against EMI interference. Preferably a 90° connector is used as it routes the wire downwards and puts less side load stress on the pickup.

Ignition Systems

### Magnetic Pickup Leads



P/N	Figure	Supersedes	Connector	Lead Length	Equivalent to
06.71.001-L	1		MIL, 2 pole, socket, 90°	"L" = 5/15/25/50 ft.	

### Hall Effect Pickup Leads



P/N	Figure	Supersedes	Connector	Lead Length	Equivalent to
06.71.002-L	2		MIL, 3 pole, socket, 90°	"L" = 5/15/25/50 ft.	

### Inductive Pickup Lead



P/N	Figure	Supersedes	Connector	Lead Length	Equivalent to
06.71.007	3		4 pole, socket, 90°	400 in.	

SHIELDED

### Magnetic Pickup Leads

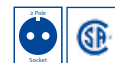

P/N <sup>1)</sup>	Figure	Supersedes	Connector	Adaptor to Outlet Box	Equivalent to
95.60.010-L	4		MIL, 2 pole, socket, 180°	1/2-14 NPT	593048-L
95.60.020-L	4		MIL, 2 pole, socket, 90°	1/2-14 NPT	593054-L

<sup>1)</sup> Standard braid lengths ("L") = 6 in., 12 in., 18 in., 24 in., 36 in., 48 in., 72 in., 96 in., 120 in., 150 in., 180 in.; other lengths available on request.

### Hall Effect Pickup Leads



P/N <sup>1)</sup>	Figure	Supersedes	Connector	Adaptor to Outlet Box	Equivalent to
95.60.030-L	5		MIL, 3 pole, socket, 180°	1/2-14 NPT	593052-L
95.60.040-L	5		MIL, 3 pole, socket, 90°	1/2-14 NPT	593057-L

<sup>1)</sup> Standard braid lengths ("L") = 6 in., 12 in., 18 in., 24 in., 36 in., 48 in., 72 in., 96 in., 120 in., 150 in., 180 in.; other lengths available on request.

### Inductive Pickup Lead



P/N	Figure	Supersedes	Connector	Lead Length	Adaptor to Outlet Box	Equivalent to
95.60.050-400	6		4 pole, socket, 90°	400 in.	M12x1.5	



Conversion: 1 inch = 25,4 mm / 1 foot = 0,3 m



## Pickups & Trigger Drives

### Trigger Discs

A large variety of different trigger discs is available to support upgrades performed by installing new electronic ignition systems on engines that used to be equipped with mechanical driven magnetos. Select between universal trigger discs with magnets, metal inlets or discs that are specially designed for particular engine models.



### Trigger Discs with Magnets

P/N	Supersedes	Description	Diameter	Events	Equivalent to
06.20.300		Trigger disc with magnet	5.00 in.	1	
06.20.301		Trigger disc with magnet	7.45 in.	1	
06.20.302		Trigger disc with magnets	5.00 in.	2+1	
06.20.303		Trigger disc with magnets	7.45 in.	2+1	
06.20.304		Trigger disc with magnets	5.00 in.	3+1	
06.20.305		Trigger disc with magnets	7.45 in.	3+1	
06.20.306		Trigger disc with magnets	5.00 in.	4+1	790114-1
06.20.307		Trigger disc with magnets	7.45 in.	4+1	790104-1
06.20.308		Trigger disc with magnets	5.00 in.	5+1	790115-1
06.20.309		Trigger disc with magnets	7.45 in.	5+1	790105-1
06.20.310		Trigger disc with magnets	3.40 in.	6+1	790165
06.20.311		Trigger disc with magnets	4.00 in.	6+1	790144
06.20.312		Trigger disc with magnets	5.00 in.	6+1	790169
06.20.313		Trigger disc with magnets	5.00 in.	6+1	790116-1
06.20.314		Trigger disc with magnets	7.45 in.	6+1	790106-1
06.20.316		Trigger disc with magnets	5.00 in.	8+1	790118-1
06.20.317		Trigger disc with magnets	7.45 in.	8+1	790150
06.20.318		Trigger disc with magnets	7.45 in.	8+1	790108-1
06.20.319		Trigger disc with magnets	7.45 in.	8+1	790022
06.20.321		Trigger disc with magnets	7.45 in.	12+1	790122-1
06.20.322		Trigger disc with magnets	7.45 in.	12+1	790151
06.20.323		Trigger disc with magnets	7.45 in.	12+1	790021

Conversion: 1 inch = 25,4 mm/1 foot = 0,3 m

## Trigger Discs with Magnets – Compatible with WAUKESHA® CEC Ignition System

P/N	Figure	Supersedes	Description	Application	Diameter	Events	Equivalent to
06.20.069-1	1		Trigger disc with magnet	WAUKESHA® VHP series	7.45 in.	1	
06.20.069-6	1		Trigger disc with magnets	WAUKESHA® VHP series – 6 cylinders	7.45 in.	6+1	305805R
06.20.069-12	1		Trigger disc with magnets	WAUKESHA® VHP series – 12 cylinders	7.45 in.	12+1	305805P
06.20.254	2		Trigger disc with magnet	WAUKESHA® VHP series	5.35 in.	1	
06.20.252	2		Trigger disc with magnets	WAUKESHA® VHP series – 16 cylinders	5.35 in.	8+1	305805N
06.20.026-1 <sup>1)</sup>	3		Trigger disc with magnet	WAUKESHA® VHP series	7.45 in.	1	
06.20.025 <sup>1)</sup>	3		Trigger disc with magnets	WAUKESHA® VHP series – 6 cylinders	7.45 in.	6+1	305805F
06.20.026 <sup>1)</sup>	3	06.20.025-1	Trigger disc with magnets	WAUKESHA® VHP series – 12 cylinders	7.45 in.	12+1	305805G
06.20.045-1	4		Trigger disc with magnet	WAUKESHA® VGF series	5.00 in.	1	
06.20.045-6	4		Trigger disc with magnets	WAUKESHA® VGF series – 6 cylinders	5.00 in.	6+1	305805
06.20.045-8	4		Trigger disc with magnets	WAUKESHA® VGF series – 8 cylinders	5.00 in.	8+1	305805A

<sup>1)</sup> Comes with lock nut.

## Accessories for Trigger Discs for WAUKESHA® VHP Series Gas Engines

P/N	Figure	Supersedes	Description	Equivalent to
06.20.070	1B		Hub for trigger discs P/N 06.20.069-X	A168368E

## Trigger Discs with Metal Inlets

P/N	Figure	Supersedes	Description	Diameter	Events	Equivalent to
06.20.400	5		Trigger disc with metal inlets	7.45 in.	2+1	790302-1
06.20.401	5		Trigger disc with metal inlets	7.45 in.	3+1	790303-1
06.20.402	5		Trigger disc with metal inlets	5.00 in.	4+1	790314-1
06.20.403	5		Trigger disc with metal inlets	5.00 in.	6+1	790316-1
06.20.404	5		Trigger disc with metal inlets	5.00 in.	8+1	790318-1

## Trigger Disc for IVECO® 5.9

P/N	Figure	Supersedes	Description	Diameter	Events	Equivalent to
06.20.251	6		Trigger disc with metal inlets	11.50 in.	3+1	



Conversion: 1 inch = 25,4 mm / 1 foot = 0,3 m

# Pickups & Trigger Drives

## Trigger Pins & Magnets

### Trigger Reluctor Pin

P/N	Figure	Supersedes	Description	Diameter	Length	Equivalent to
06.80.104	1		Trigger reluctor pin	0.25 in.	0.75 in.	

See page 58 for reluctor pin installation tool.

### Trigger Magnets

P/N	Figure	Supersedes	Description	Thread	Length	Equivalent to
06.60.900	2		Trigger magnet	1/4-20 UNC	0.65 in.	
06.60.922	2		Trigger magnet	M8x1.25	0.70 in.	720002
06.60.925	3		Trigger magnet for CATERPILLAR® G3500 series	M8x1.25	1.34 in.	260605, 260604

## Trigger Drives

### Trigger Conversion Kits for CATERPILLAR® G3300 & G3400 Series Gas Engines

P/N	Figure	Supersedes	Description	Events	Equivalent to
75.30.131-1	4	75.30.119-1, 75.30.101-1	Trigger conversion kit for CATERPILLAR® G3304/3306	1	
75.30.132 <sup>1)</sup>	4	75.30.119	Trigger conversion kit for CATERPILLAR® G3304	4+1	
75.30.131 <sup>1)</sup>	4	75.30.101	Trigger conversion kit for CATERPILLAR® G3306	6+1	
75.30.133-1	4	75.30.100-1	Trigger conversion kit for CATERPILLAR® G3406	1	
75.30.133 <sup>1)</sup>	4	75.30.100	Trigger conversion kit for CATERPILLAR® G3406	6+1	

<sup>1)</sup> Trigger conversion kits also included in ignition kits (unshielded/shielded) for CATERPILLAR® G3300 & G3400 series gas engines.

### Accessories for Trigger Conversion Kits for CATERPILLAR® G3300 & G3400 Series Gas Engines

P/N	Figure	Supersedes	Description	Engine	Equivalent to
24.95.002 <sup>1)</sup>	4a		Flange cover plate for magneto	G3300, G3400	
44.04.005 <sup>2)</sup>	4b		Fork spanner, swan-necked	G3406	

<sup>1)</sup> Flange cover plate also included in ignition kits (unshielded/shielded) for CATERPILLAR® G3300 & G3400 series gas engines.

<sup>2)</sup> Needs to be ordered separately.



1



2



3



4

# Pickups & Trigger Drives



## Trigger Conversion Kit for DOOSAN® GV222TI Gas Engine

P/N	Figure	Supersedes	Description	Events	Equivalent to
75.30.137 <sup>1)</sup>	5		Trigger conversion kit for DOOSAN® GV222TI	6+1	

<sup>1)</sup> Required pickup P/N 66.60.003-60 and lead P/N 06.71.007 have to be ordered separately. Only for use, when GILL® ignition system was installed before. Illustration shows mounted kit on camshaft gear.

## Trigger Drives for WHITE SUPERIOR® G825 & GT825 Gas Engines

P/N	Figure	Supersedes	Description	Events	Equivalent to
06.22.400-1 <sup>1)</sup>	6		Trigger drive for WHITE SUPERIOR® G825, GT825	1	
06.22.400-6 <sup>1)</sup>	6		Trigger drive for WHITE SUPERIOR® G825, GT825	6+1	
06.22.400-8 <sup>1)</sup>	6		Trigger drive for WHITE SUPERIOR® G825, GT825	8+1	

<sup>1)</sup> Required pickup P/N 66.60.003-60 and lead P/N 06.71.007 have to be ordered separately.

## Trigger Drive for MAN® E2842 E302 & DOOSAN® GV222TI Gas Engines

P/N	Figure	Supersedes	Description	Events	Equivalent to
06.23.001 <sup>1)</sup>	7		Trigger drive for MAN® E2842 E302 & DOOSAN® GV222TI	6+1	

<sup>1)</sup> Required pickup P/N 66.60.003-60 and lead P/N 06.71.007 have to be ordered separately.

## Trigger Drive for MAN® E2866 E302 Gas Engine

P/N	Figure	Supersedes	Description	Events	Equivalent to
06.23.004 <sup>1)</sup>	8		Trigger drive for MAN® E2866 E302	6+1	

<sup>1)</sup> Required pickup P/N 66.60.003-60 and lead P/N 06.71.007 have to be ordered separately.



# Pickups & Trigger Drives

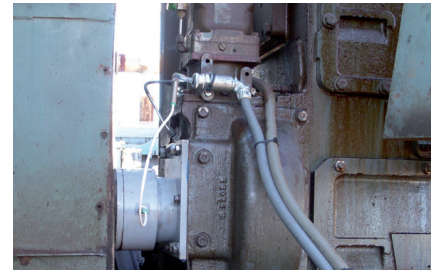

## Trigger Devices

For applications where a trigger disc cannot be mounted due to difficult camshaft access, a trigger device is available. This unit is mounted at the location where the ignition magneto was installed. A built-in trigger disc will sense the events necessary to trigger the ignition control unit. One (1) to a maximum of eight (8) trigger events are possible.

This covers most of the engines up to 16 cylinders operated in the field today. A proper mounting flange can be selected from a variety of flange designs typically used in the industry. Heavy duty bearings and a smart product design offer a long operating life cycle.

## Specification Table

Before trying to specify the correct trigger device, please make available the ignition magneto part number. For details you might even want to look up the ALTRONIC® application chart. That information will lead you to the MOTORTECH TriDev part number. If any help is required, please call your nearest MOTORTECH sales partner.

ALTRONIC III MEDIUM ENGINES, 2-16 CYLINDERS		IDENTIFICATION FORM AHJ AL 12-95
ALTRONIC III UNIT PART NO. DESIGNATION		
A Z 9 H.T. - B.E.L.		
MOUNTING		A = Vertical Flange, 1 slot BE = Base Mount, adjustable C = Horizontal Flange, 1.007 slot, 2 slots E = Base Mount, fixed G = Horizontal Flange, 2 slots H = Horizontal Flange, fine coupling GN = Horizontal Flange, gear coupling GV = Vertical Flange, 2 slots, gear coupling V = Vertical Flange, 2 slots
OPTIONS		H = High Output Option T = Electronic Timing Option
STATION WINDING		0 = 271 000 1 = 271 001 2 = 271 002 3 = 271 003 4 = 271 004 5 = 271 005 6 = 271 006
GEAR RATIO		1 = 1:1 2 = 2:1 3 = 3:1 4 = 4:1 5 = 5:1 6 = 1:10:1
FIRING PATTERN		A = Even Firing Pattern Other Letters = Odd Firing Pattern
NO. CYLINDERS		2, 3, 4, 5, 6, 7, 8, 9, 10, 12, 16

Refer to **ALTRONIC III Application List – Chapter Identification** – and choose **Gear Ratio** from **Part Number Designation** of former used magneto.

ALTRONIC III MEDIUM ENGINES, 2-16 CYLINDERS		APPLICATION LIST FORM AHJ AL 12-95			
ENGINE / MODEL NO.	DRIVE RATIO	ALTRONIC III UNIT NO.	WIRING COILS	QTY.	NOTES
<b>CATERPILLAR</b>					
3303	1:1	6A394A	303 032-1	6	S.H.
3304	1:1	6A394A	303 032-2	6	S.H.
3305	1:1	6A394A	303 032-3	6	S.H.
3306	1:1	6A394A	303 032-4	6	S.H.
3307	1:1	6A394A	303 032-5	6	S.H.
3308	1:1	6A394A	303 032-6	6	S.H.
3309	1:1	6A394A	303 032-7	6	S.H.
3310	1:1	6A394A	303 032-8	6	S.H.
3311	1:1	6A394A	303 032-9	6	S.H.
3312	1:1	6A394A	303 032-10	6	S.H.
3313	1:1	6A394A	303 032-11	6	S.H.
3314	1:1	6A394A	303 032-12	6	S.H.
3315	1:1	6A394A	303 032-13	6	S.H.
3316	1:1	6A394A	303 032-14	6	S.H.
3317	1:1	6A394A	303 032-15	6	S.H.
3318	1:1	6A394A	303 032-16	6	S.H.
3319	1:1	6A394A	303 032-17	6	S.H.
3320	1:1	6A394A	303 032-18	6	S.H.
3321	1:1	6A394A	303 032-19	6	S.H.
3322	1:1	6A394A	303 032-20	6	S.H.
3323	1:1	6A394A	303 032-21	6	S.H.
3324	1:1	6A394A	303 032-22	6	S.H.
3325	1:1	6A394A	303 032-23	6	S.H.
3326	1:1	6A394A	303 032-24	6	S.H.
3327	1:1	6A394A	303 032-25	6	S.H.
3328	1:1	6A394A	303 032-26	6	S.H.
3329	1:1	6A394A	303 032-27	6	S.H.
3330	1:1	6A394A	303 032-28	6	S.H.
3331	1:1	6A394A	303 032-29	6	S.H.
3332	1:1	6A394A	303 032-30	6	S.H.
3333	1:1	6A394A	303 032-31	6	S.H.
3334	1:1	6A394A	303 032-32	6	S.H.
3335	1:1	6A394A	303 032-33	6	S.H.
3336	1:1	6A394A	303 032-34	6	S.H.
3337	1:1	6A394A	303 032-35	6	S.H.
3338	1:1	6A394A	303 032-36	6	S.H.
3339	1:1	6A394A	303 032-37	6	S.H.
3340	1:1	6A394A	303 032-38	6	S.H.
3341	1:1	6A394A	303 032-39	6	S.H.
3342	1:1	6A394A	303 032-40	6	S.H.
3343	1:1	6A394A	303 032-41	6	S.H.
3344	1:1	6A394A	303 032-42	6	S.H.
3345	1:1	6A394A	303 032-43	6	S.H.
3346	1:1	6A394A	303 032-44	6	S.H.
3347	1:1	6A394A	303 032-45	6	S.H.
3348	1:1	6A394A	303 032-46	6	S.H.
3349	1:1	6A394A	303 032-47	6	S.H.
3350	1:1	6A394A	303 032-48	6	S.H.
3351	1:1	6A394A	303 032-49	6	S.H.
3352	1:1	6A394A	303 032-50	6	S.H.
3353	1:1	6A394A	303 032-51	6	S.H.
3354	1:1	6A394A	303 032-52	6	S.H.
3355	1:1	6A394A	303 032-53	6	S.H.
3356	1:1	6A394A	303 032-54	6	S.H.
3357	1:1	6A394A	303 032-55	6	S.H.
3358	1:1	6A394A	303 032-56	6	S.H.
3359	1:1	6A394A	303 032-57	6	S.H.
3360	1:1	6A394A	303 032-58	6	S.H.
3361	1:1	6A394A	303 032-59	6	S.H.
3362	1:1	6A394A	303 032-60	6	S.H.
3363	1:1	6A394A	303 032-61	6	S.H.
3364	1:1	6A394A	303 032-62	6	S.H.
3365	1:1	6A394A	303 032-63	6	S.H.
3366	1:1	6A394A	303 032-64	6	S.H.
3367	1:1	6A394A	303 032-65	6	S.H.
3368	1:1	6A394A	303 032-66	6	S.H.
3369	1:1	6A394A	303 032-67	6	S.H.
3370	1:1	6A394A	303 032-68	6	S.H.
3371	1:1	6A394A	303 032-69	6	S.H.
3372	1:1	6A394A	303 032-70	6	S.H.
3373	1:1	6A394A	303 032-71	6	S.H.
3374	1:1	6A394A	303 032-72	6	S.H.
3375	1:1	6A394A	303 032-73	6	S.H.
3376	1:1	6A394A	303 032-74	6	S.H.
3377	1:1	6A394A	303 032-75	6	S.H.
3378	1:1	6A394A	303 032-76	6	S.H.
3379	1:1	6A394A	303 032-77	6	S.H.
3380	1:1	6A394A	303 032-78	6	S.H.
3381	1:1	6A394A	303 032-79	6	S.H.
3382	1:1	6A394A	303 032-80	6	S.H.
3383	1:1	6A394A	303 032-81	6	S.H.
3384	1:1	6A394A	303 032-82	6	S.H.
3385	1:1	6A394A	303 032-83	6	S.H.
3386	1:1	6A394A	303 032-84	6	S.H.
3387	1:1	6A394A	303 032-85	6	S.H.
3388	1:1	6A394A	303 032-86	6	S.H.
3389	1:1	6A394A	303 032-87	6	S.H.
3390	1:1	6A394A	303 032-88	6	S.H.
3391	1:1	6A394A	303 032-89	6	S.H.
3392	1:1	6A394A	303 032-90	6	S.H.
3393	1:1	6A394A	303 032-91	6	S.H.
3394	1:1	6A394A	303 032-92	6	S.H.
3395	1:1	6A394A	303 032-93	6	S.H.
3396	1:1	6A394A	303 032-94	6	S.H.
3397	1:1	6A394A	303 032-95	6	S.H.
3398	1:1	6A394A	303 032-96	6	S.H.
3399	1:1	6A394A	303 032-97	6	S.H.
3400	1:1	6A394A	303 032-98	6	S.H.
3401	1:1	6A394A	303 032-99	6	S.H.
3402	1:1	6A394A	303 032-100	6	S.H.

Refer to **ALTRONIC III Application List** and choose **Rotation** of your engine make and model from the list.

Selection **1 to 8** for use with inductive pickups only. Requires - **E - Pickup Port Arrangement A**. Selection **9** for use with Hall effect pickups only. Requires - **E - Pickup Port Arrangement F**.

ALTRONIC III MEDIUM ENGINES, 2-16 CYLINDERS		IDENTIFICATION FORM AHJ AL 12-95
<p>Refer to <b>ALTRONIC III Application List - Chapter Identification</b> - and choose Flange option from Part Number Designation of former used magneto.</p>		
<p>Selection <b>A</b> to be used for - <b>C - Trigger Arrangement 1 to 8</b> only. Selection <b>F</b> to be used for - <b>C - Trigger Arrangement 9</b> only.</p>		

Refer to **ALTRONIC III Application List - Chapter Identification** - and choose Flange option from Part Number Designation of former used magneto.

Selection **A** to be used for - **C - Trigger Arrangement 1 to 8** only. Selection **F** to be used for - **C - Trigger Arrangement 9** only.

# Pickups & Trigger Drives

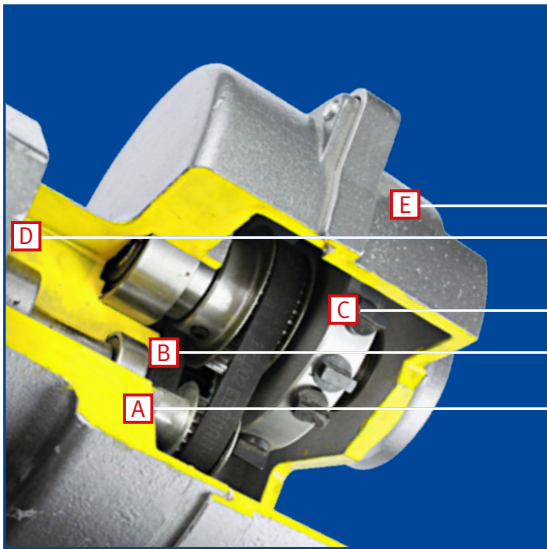

P/N 06.22. **A B C - D - E**

**A Gear Ratio**

1	1:1
2	2:1
3	3:1
6	1.5:1

**B Rotation**

1	CW (clockwise)
2	CCW (counterclockwise)

**C Trigger Arrangement**

1	1 only	Pin	Multiple pickup arrangement
2	2+1	Pin	Single pickup arrangement
3	3+1	Pin	Single pickup arrangement
4	4+1	Pin	Single pickup arrangement
6	6+1	Pin	Single pickup arrangement
8	8+1	Pin	Single pickup arrangement
9	1 only	Magnet	Multiple pickup arrangement

**D Flange**

A	Flange mount, vertical, 1 slot
B	Base mount
D	Flange mount, horizontal, 3 in. pilot, 2 slots
G	Flange mount, horizontal, 2 slots
GL	Flange mount, horizontal, flex coupling
GN	Flange mount, horizontal, gear coupling
GO	Flange mount, horizontal, 2 slots
GV	Flange mount, vertical, 2 slots
GVN	Flange mount, vertical, gear coupling
J	Flange mount, vertical, 3 slots

**E Pickup Port Arrangement**

A	M12 x 1	Pickup port for inductive pickup
F	5/8-18 UNF	Pickup port for Hall effect pickup

NOTE: Pickup and lead have to be ordered separately.

# Pickups & Trigger Drives

## Tools & Accessories

### Installation Tool for Trigger Reluctor Pin

P/N	Figure	Supersedes	Description	Equivalent to
44.99.011	1		Installation tool for trigger reluctor pin	

### Thread Adaptors

P/N	Figure	Supersedes	Description	Outer Thread	Inner Thread	Length	Equivalent to
06.60.908	2		Thread Adaptor	5/8-18 UNF	M12x1	40 mm	
06.60.926	2		Thread Adaptor	M18x1	M12x1	40 mm	
06.95.058	2		Thread Adaptor	3/4-16 UNF	M12x1	24 mm	

### Junction Boxes

P/N	Figure	Supersedes	Description	Connection	Hubs	Equivalent to
15.02.226	3		Junction box	1/2 in.	2	
15.02.326	4		Junction box	1/2 in.	3	
15.02.426	5		Junction box	1/2 in.	4	

### Drive Coupling for Magnetos and TriDev Trigger Devices

P/N	Figure	Supersedes	Description	Equivalent to
06.75.103	6	06.75.102	Drive coupling with roll pin, black	510454-P, 510454-U

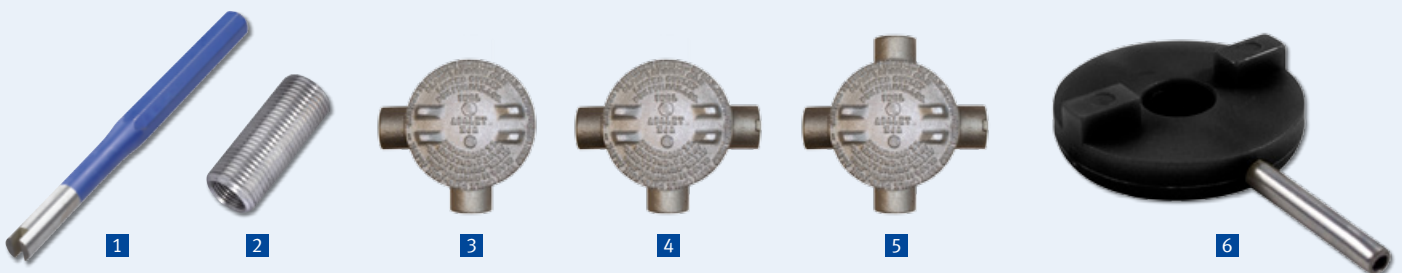





# Primary Leads

## SHIELDED

### Primary Leads – New Flex Style

In addition to its conventional primary leads, MOTORTECH offers a new type of primary lead that is produced with a special wire. The new primary leads are compliant with CSA Class I, Division 2, Group D, and they offer a significantly higher flexibility than conventional leads, shielded with braided steel, while being highly resistant to all kinds of environmental conditions.

The multi-layer design of the wire is free of entrapped air and prevents the accumulation of condensed water which can result in primary voltage flash-overs. Several different configurations with durable 90-degree and 180-degree 2-pole and 3-pole connectors are available.

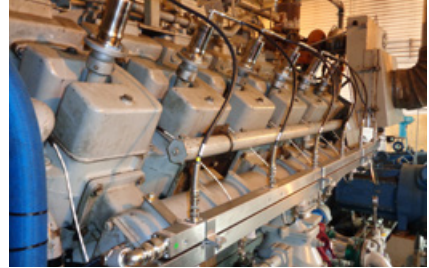

**New Flex Style**



**Conventional Style**



The oil and UV resistant multi-conductor wire is specially designed for shielded CSA certified primary leads. It consists of a multi layer design:

- Fine bare copper wire
- PVC/Nylon insulation
- Aluminum-plated foil and tinned copper braid
- PVC jacket
- Temperature range -40° C to +90° C (-40° F to +194° F)

This design ensures that no humidity can be trapped in the lead.

# Primary Leads

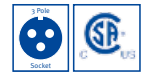

## Primary Leads – 3 Pole Ignition Coil Connection – NPT Adaptors to Outlet Box

Shielded		Unshielded	Ignition Coil Connector	Outlet Box Adaptor	Conductor	Equivalent to
New Flex Style	Conventional Style					
P/N <sup>1)</sup>						
95.01.110-L	95.01.010-L		MIL, 3 pole, socket, 180°	1/2-14 NPT, 180°	2 wire	593022-L
95.01.110-L-3	95.01.010-L-3		MIL, 3 pole, socket, 180°	3/8-18 NPT, 180°	2 wire	LT73002-L
95.01.120-L	95.01.020-L		MIL, 3 pole, socket, 90°	1/2-14 NPT, 180°	2 wire	593027-L
95.01.120-L-3	95.01.020-L-3		MIL, 3 pole, socket, 90°	3/8-18 NPT, 180°	2 wire	LT73012-L
95.01.121-L	95.01.021-L		MIL, 3 pole, socket, 90°	1/2-14 NPT, 180°	2 wire	593029-L
95.01.122-L	95.01.022-L		MIL, 3 pole, socket, 90°	1/2-14 NPT, 180°	2 wire <sup>2)</sup>	593036-L
95.01.123-L	95.01.023-L		MIL, 3 pole, socket, 180°	1/2-14 NPT, 180°	2 wire <sup>2)</sup>	593035-L

<sup>1)</sup> Standard braid lengths (“-L”) = 6 in., 9 in., 12 in., 15 in., 18 in., 24 in., 30 in., 36 in., 42 in., 48 in., 54 in., 60 in., 72 in., 84 in., 96 in., 108 in., 120 in., 135 in., 138 in., 150 in.; other lengths available on request.

<sup>2)</sup> Wire length is double of braid length.

## Repair Kits for Conventional Style Shielded Primary Leads – 3 Pole Ignition Coil Connection



P/N	Description	Lead Length	Ignition Coil Connector	Conductor	For use with Primary Lead, Length 10 to 180 in.	Equivalent to
95.01.010-42-RC	Repair kit	42 in.	MIL, 3 pole, socket, 180°	2 wire	95.01.010-L, 593022-L	583017-42
95.01.010-60-RC	Repair kit	60 in.	MIL, 3 pole, socket, 180°	2 wire	95.01.010-L, 593022-L	583017-60
95.01.010-96-RC	Repair kit	96 in.	MIL, 3 pole, socket, 180°	2 wire	95.01.010-L, 593022-L	583017-96
95.01.010-180-RC	Repair kit	180 in.	MIL, 3 pole, socket, 180°	2 wire	95.01.010-L, 593022-L	583017-180
95.01.020-42-RC	Repair kit	42 in.	MIL, 3 pole, socket, 90°	2 wire	95.01.020-L, 593027-L	583018-42
95.01.020-60-RC	Repair kit	60 in.	MIL, 3 pole, socket, 90°	2 wire	95.01.020-L, 593027-L	583018-60
95.01.020-96-RC	Repair kit	96 in.	MIL, 3 pole, socket, 90°	2 wire	95.01.020-L, 593027-L	583018-96
95.01.020-180-RC	Repair kit	180 in.	MIL, 3 pole, socket, 90°	2 wire	95.01.020-L, 593027-L	583018-180



Ignition Systems

# Primary Leads

## Primary Leads – 2 Pole Ignition Coil Connection – NPT Adaptors to Outlet Box

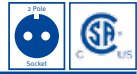

Shielded		Unshielded	Ignition Coil Connector	Outlet Box Adaptor	Conductor	Equivalent to
New Flex Style	Conventional Style					
P/N <sup>1)</sup>						
95.06.110-L	95.06.010-L		MIL, 2 pole, socket, 180°	1/2-14 NPT, 180°	2 wire	A754-L, LT2001-L
95.06.120-L	95.06.020-L		MIL, 2 pole, socket, 90°	1/2-14 NPT, 180°	2 wire	B754-L, LT2011-L
	95.06.030-L		MIL, 2 pole, socket, 180°	5/8-24 NPT, 90°	2 wire	C754-L, LT2100-L

<sup>1)</sup> Standard braid lengths (“-L”) = 6 in., 9 in., 12 in., 15 in., 18 in., 24 in., 30 in., 36 in., 42 in., 48 in., 54 in., 60 in., 72 in., 84 in., 96 in., 108 in., 120 in., 135 in., 138 in., 150 in.; other lengths available on request.

## Primary Leads – 3 Pole Ignition Coil Connection – Special



Shielded		Unshielded	Ignition Coil Connector	Electronic Box Connector	Conductor	Equivalent to
New Flex Style	Conventional Style					
P/N <sup>1)</sup>						
95.01.130-L	95.01.030-L		MIL, 3 pole, socket, 90°	MIL, 3 pole, socket, 180°	2 wire	593069-L
95.01.131-L	95.01.031-L		MIL, 3 pole, socket, 90°	MIL, 3 pole, pin, 90°	2 wire	
95.01.133-L	95.01.033-L		MIL, 3 pole, socket, 90°	MIL, 3 pole, socket, 180°	3 wire	

<sup>1)</sup> Standard braid lengths (“-L”) = 6 in., 9 in., 12 in., 15 in., 18 in., 24 in., 30 in., 36 in., 42 in., 48 in., 54 in., 60 in., 72 in., 84 in., 96 in., 108 in., 120 in., 135 in., 138 in., 150 in.; other lengths available on request.

## Primary Leads – 2 Pole Ignition Coil Connection – Special

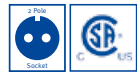

Shielded		Unshielded	Ignition Coil Connector	Electronic Box Connector	Conductor	Equivalent to
New Flex Style	Conventional Style					
P/N <sup>1)</sup>						
95.01.132-L	95.01.032-L		MIL, 2 pole, pin, 90°	MIL, 2 pole, pin, 90°	2 wire	

<sup>1)</sup> Standard braid lengths (“-L”) = 6 in., 9 in., 12 in., 15 in., 18 in., 24 in., 30 in., 36 in., 42 in., 48 in., 54 in., 60 in., 72 in., 84 in., 96 in., 108 in., 120 in., 135 in., 138 in., 150 in.; other lengths available on request.



# Primary Leads



## Cable Assemblies – NPT Adaptors to Outlet Box



Shielded		Unshielded	Ignition Coil Connector	Outlet Box Adaptor	Conductor	Equivalent to
New Flex Style	Conventional Style					
P/N <sup>1)</sup>						
95.01.111-L	95.01.011-L		MIL, 3 pole, socket, 180°	1/2-14 NPT, 180°	3 wire	
95.01.124-L	95.01.024-L		MIL, 3 pole, socket, 90°	1/2-14 NPT, 180°	3 wire	593024-L
	95.01.025-L		MIL, 4 pole, socket, 90°	1/2-14 NPT, 180°	5 wire	593025-L
	95.01.026-L		MIL, 5 pole, socket, 90°	1/2-14 NPT, 180°	6 wire	593026-L

<sup>1)</sup> Standard braid lengths (“-L”) = 6 in., 9 in., 12 in., 15 in., 18 in., 24 in., 30 in., 36 in., 42 in., 48 in., 54 in., 60 in., 72 in., 84 in., 96 in., 108 in., 120 in., 135 in., 138 in., 150 in.; other lengths available on request.

## Special Application Primary Leads

### Primary Leads for ROLLS-ROYCE® Gas Engines



Shielded		Unshielded	Ignition Coil Connector	Wiring Rail Connector	Conductor	Equivalent to
New Flex Style	Conventional Style					
P/N <sup>1)</sup>						
	95.01.012-14		MIL, 3 pole, socket, 90°	3 pole, socket, 90°	2 wire	702930, 593068-1
	95.01.013-30		MIL, 3 pole, socket, 90°	3 pole, socket, 180°	2 wire	705165, 593068-2

<sup>1)</sup> Standard braid lengths 14 in. and 30 in.; other lengths available on request.

### Primary Leads for WAUKESHA® ESM Gas Engines



Shielded		Unshielded	Ignition Coil Connector	Wiring Rail Connector	Conductor	Equivalent to
New Flex Style	Conventional Style					
P/N						
95.01.107-24 <sup>1)</sup>		A740746-MOT	MIL, 3 pole, socket, 90°	3 pole, socket, 180°	2 wire	A740746, 740746D
		740746B-MOT	2 wire, 180°	3 pole, socket, 180°	2 wire	740746B

<sup>1)</sup> Standard lead length 24 in.; other lengths available on request.

### Primary Lead for ALTRONIC® EZRAIL Ignition Rail System – Unshielded



P/N <sup>1)</sup>	Description	Ignition Coil Connector	Lead Length	Conductor	Equivalent to
06.30.111-60	Primary lead	MIL, 3 pole, socket, 180°	60 in.	2 wire	583017-60KT

<sup>1)</sup> Other lengths available on request.



Primary Leads for WAUKESHA® ESM Gas Engines

# Primary Leads



## Primary Leads for MOTORTECH AlphaRail Wiring Rails

For linking flange, integral or externally mounted ignition coils to its AlphaRail ignition wiring rails, MOTORTECH offers a special series of primary leads. Several different configurations are available to offer an individual solution for any application.

- 1 2 or 3 pole MIL style connectors as 90° or 180° type for ignition coil connection
- 2 Primary leads available for shielded applications (Conventional or New Flex Style) or unshielded applications
- 3 2 pole MIL style connector as 90° or 180° type for wiring rail connection



Shielded		Unshielded	Ignition Coil Connector	Wiring Rail Connector	Conductor	Equivalent to
New Flex Style	Conventional Style					
P/N <sup>1)</sup>						
95.01.140-L	95.01.040-L	06.01.040-L	MIL, 3 pole, socket, 180°	MIL, 2 pole, pin, 180°	2 wire	
95.01.141-L	95.01.041-L	06.01.041-L	MIL, 3 pole, socket, 90°	MIL, 2 pole, pin, 180°	2 wire	
95.01.142-L	95.01.042-L	06.01.042-L	MIL, 2 pole, socket, 180°	MIL, 2 pole, pin, 180°	2 wire	
95.01.143-L	95.01.043-L	06.01.043-L	MIL, 2 pole, socket, 90°	MIL, 2 pole, pin, 180°	2 wire	
95.01.144-L	95.01.044-L	06.01.044-L	MIL, 3 pole, socket, 180°	MIL, 2 pole, pin, 90°	2 wire	
95.01.145-L	95.01.045-L	06.01.045-L	MIL, 3 pole, socket, 90°	MIL, 2 pole, pin, 90°	2 wire	
95.01.146-L	95.01.046-L	06.01.046-L	MIL, 2 pole, socket, 180°	MIL, 2 pole, pin, 90°	2 wire	
95.01.147-L	95.01.047-L	06.01.047-L	MIL, 2 pole, socket, 90°	MIL, 2 pole, pin, 90°	2 wire	

<sup>1)</sup> Standard lead lengths ("-L") = 6 in., 9 in., 12 in., 15 in., 18 in., 24 in., 30 in., 36 in., 42 in., 48 in., 54 in., 60 in., 72 in., 84 in.; other lengths available on request. Add suffix "-X" to part number for cross wired primary leads for positive grounded ignition systems (e.g. 95.01.140-18-X).

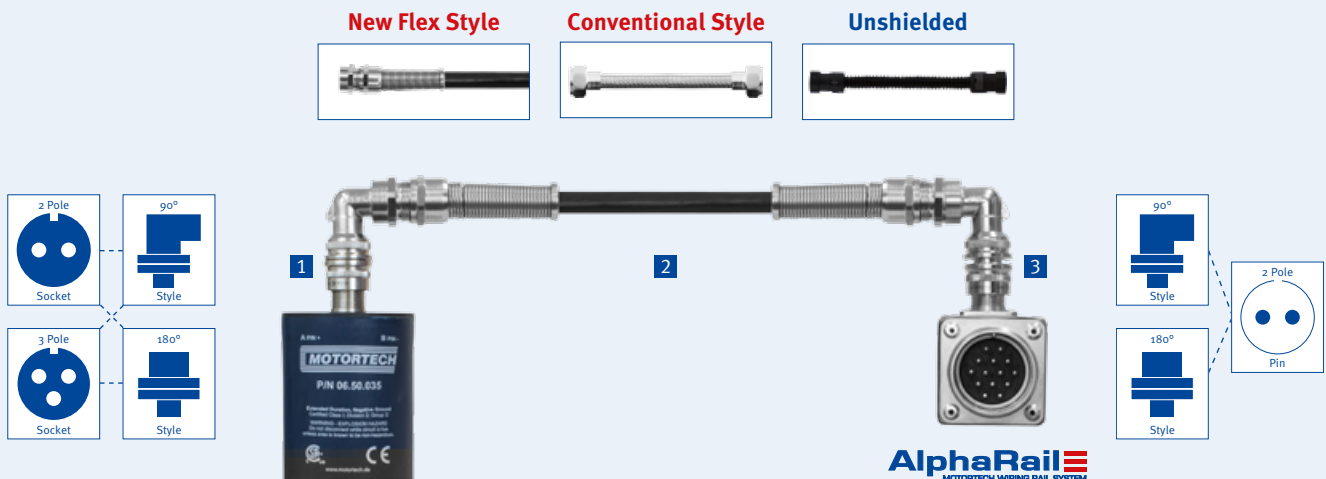





# Spark Plug Leads & Extensions

UNSHIELDED



## PolyMot™ Spark Plug Leads

MOTORTECH's PolyMot™ spark plug lead was globally patented in 1996. Since then more than one million leads were manufactured to this design. These spark plug leads are unique and offer several advantages when being compared to the OEM or aftermarket competition. With the knowledge gathered in ignition control and ignition coil research and manufacturing, a lot of the details were implemented into these products. The unique structure has achieved tremendous reliability records in the field.

### General Features

- Rigid design
- Extensions made of high quality TEFLON® and up to 36 in. length
- Ceramic insert with 5 kΩ resistor for EMI suppression (0 kΩ available on request)
- Reliable ignition coil and spark plug terminal
- Critical high voltage areas are protected with seals
- Designed to match the engine model, the spark plug type and application
- Extensions are labeled with P/N and production code for easy traceability
- Long life product

### Key Design Features

- 1 Reliable terminals to fit a large variety of different ignition coil types
- 2 The blue silicone wire is specially designed for high dielectric strength
- 3 Special silicone boots for wire output with excellent temperature and aging characteristics
- 4 Highest dielectric strength due to TEFLON® insulator
- 5 Ceramic insert with 5 kΩ resistor for EMI suppression
- 6 Integrated silicone seal rings for best flashover protection will not stick on the spark plug insulator when pulling off the extension

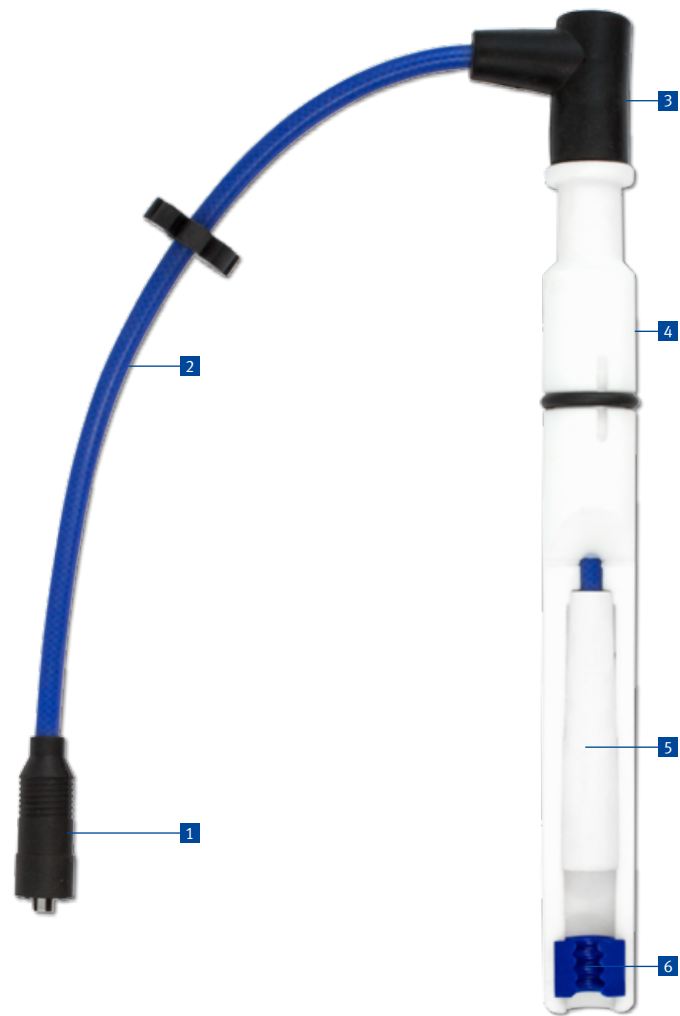
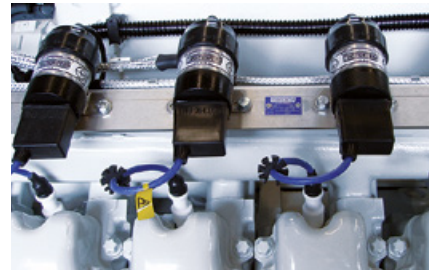

# Spark Plug Leads & Extensions



## Specification Chart

Please consult factory or your nearest MOTORTECH distributor to get the correct PolyMot™ spark plug lead, specified for your engine application.

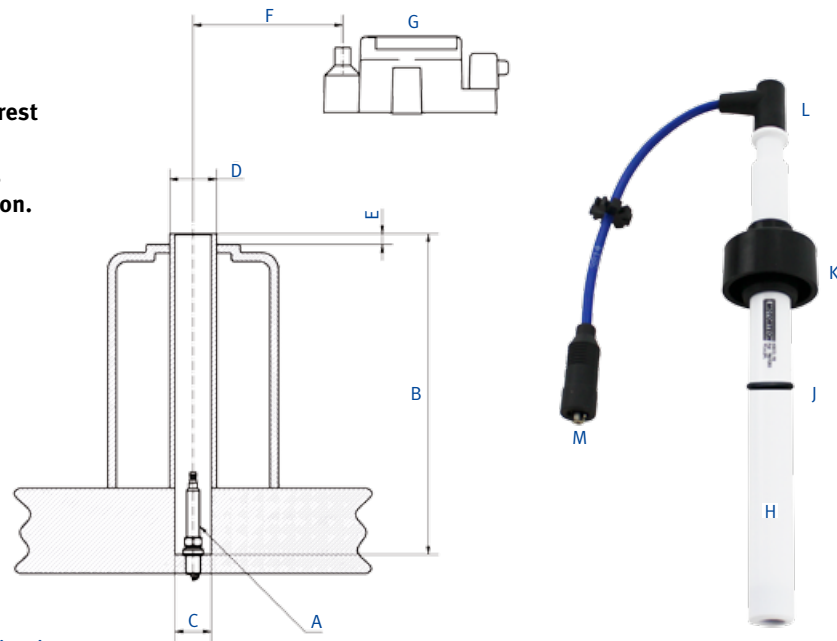

Questionnaire for PolyMot™ specification.

Engine make	
Series	
Engine model	
Spark plug make and model <b>A</b>	
Spark plug well depth <b>B</b>	
Spark plug well inner diameter <b>C</b>	
Spark plug well outer diameter <b>D</b>	
Spark plug well to cover distance <b>E</b>	
Length of wire <b>F</b>	
Ignition coil make and model <b>G</b>	
Built in 5 kΩ ceramic resistor (recommended) <b>H</b>	<input type="checkbox"/> Yes <input type="checkbox"/> No
Seal ring on Teflon insulator <b>J</b>	<input type="checkbox"/> Yes <input type="checkbox"/> No
Grommet to cover the spark plug well <b>K</b>	<input type="checkbox"/> Yes <input type="checkbox"/> No
Lead output from Teflon insulator <b>L</b>	<input type="checkbox"/> 90° <input type="checkbox"/> 180°
Terminal to ignition coil (preferred) <b>M</b>	<input type="checkbox"/> 90° <input type="checkbox"/> 180°

# Spark Plug Leads & Extensions

## UNSHIELDED

### PolyMot™ Spark Plug Leads – for common Applications

P/N	Engine Make	Model	Spark Plug	P/N Silicone Seal Ring	Extension Length	Resistance <sup>1)</sup>	Lead Output from Extension	Wire Length <sup>2)</sup>	Ignition Coil Connection
06.85.908-22	AJAX®	2802	3076	06.84.059	6 in.	6 kΩ	180°	17 in.	6
06.85.1047-24	AJAX®	DPC2802	W80N	06.84.040	5 in.	5 kΩ	180°	19 in.	5A
06.85.751-18	CATERPILLAR®	G3400 series	GE3-5/RN79G	06.84.059	13 in.	5 kΩ	90°	18 in.	1
06.85.1054-18	CATERPILLAR®	G3400 series	B4321	06.84.044	13 in.	5 kΩ	90°	18 in.	1
06.85.1019-16	CATERPILLAR®	G3400 series	GE3-5/RN79G	06.84.059	13 in.	6 kΩ	90°	18 in.	6
06.85.594-22	CATERPILLAR®	G3500 series	GI3-3/FB77WPCC	06.84.040	15 in.	5 kΩ	90°	16 in.	1
06.85.954-16	CATERPILLAR®	G3500 series	GI3-3/FB77WPCC	06.84.040	15 in.	6 kΩ	90°	16 in.	6
06.85.966-35	CLARK®	TCV-16	GK3-5/RC78PYP	06.84.044	11 in.	5 kΩ	180°	24 in.	5A
06.85.1020-24	CLARK®	TCVD12	RW80N	06.84.040	7 in.	5 kΩ	90°	24 in.	5A
06.85.505-18	CLARK®	TLA-6	RW80N	06.84.040	11 in.	5 kΩ	90°	18 in.	5A
06.85.670-16	COOPER®	GMV-8	RW77PP	06.84.040	11 in.	5 kΩ	90°	12 in.	5A
06.85.1047-24	COOPER®	GMV-8	W80N	06.84.040	5 in.	5 kΩ	180°	19 in.	5A
06.85.910-18	COOPER®	LSV-16 (Centre Spark Plug)	RW80PP	06.84.040	22 in.	5 kΩ	90°	18 in.	1
06.85.958-16	COOPER®	LSV-16 (Centre Spark Plug)	RW80PP	06.84.040	22 in.	5 kΩ	90°	16 in.	5A
06.85.909-24	COOPER®	LSV-16 (Side Spark Plug)	RW80PP	06.84.040	14 in.	5 kΩ	90°	24 in.	1
06.85.957-22	COOPER®	LSV-16 (Side Spark Plug)	RW80PP	06.84.040	14 in.	5 kΩ	90°	22 in.	5A
06.85.083-22	CUMMINS®	5.9 / GTA 8.3	GK3-5/RC78PYP	06.84.033	6 in.	5 kΩ	180°	16 in.	4
06.85.683-18	CUMMINS®	G855	GK3-5/RC78PYP	06.84.044	12 in.	5 kΩ	90°	18 in.	1
06.85.1014-12	CUMMINS®	KTA19GC	GE3-5/RN79G	06.84.059	14 in.	5 kΩ	90°	12 in.	1
06.85.1066-12	CUMMINS®	KTA19GC	GE3-5/RN79G	06.84.059	14 in.	5 kΩ	90°	12 in.	8
06.85.1068-18	DOOSAN®	GV222TIC	GK3-5/RC78PYP	06.84.033	6 in.	5 kΩ	180°	12 in.	1
06.85.835-18	DOOSAN®	GV222TIC	GK3-5/RC78PYP	06.84.033	6 in.	5 kΩ	180°	12 in.	6
06.85.528-14	GUASCOR®	SFGLD series	GI3-1/FB77WPCC	06.84.040	11 in.	5 kΩ	180°	14 in.	1
06.85.586-14	GUASCOR®	SFGLD series	GI3-1/FB77WPCC	06.84.040	11 in.	5 kΩ	180°	14 in.	2
06.85.864-26	GUASCOR®	SFGLD series	GI3-1/FB77WPCC	06.84.040	11 in.	5 kΩ	180°	14 in.	7
06.85.926-20	IVECO®	GE8291SRG75	GK3-5/RC78PYP	06.84.044	10 in.	5 kΩ	90°	20 in.	1
06.85.487-18	LIEBHERR®	G924 / G926	GK3-5/RC78PYP	06.84.033	6 in.	5 kΩ	180°	12 in.	2
06.85.873-18	LIEBHERR®	G926TI	GK3-5/RC78PYP	06.84.033	6 in.	5 kΩ	180°	12 in.	7
06.85.709H-18	MAN®	E0834E/LE / E0836E	GK3-5/RC78PYP	06.84.044	6 in.	5 kΩ	180°	10 in.	1
06.85.577H-16	MAN®	E0834E/LE / E0836E	GK3-5/RC78PYP	06.84.044	6 in.	5 kΩ	180°	10 in.	2
06.85.717H-24	MAN®	E0834E/LE / E0836E	GK3-5/RC78PYP	06.84.044	6 in.	6 kΩ	180°	18 in.	6
06.85.1037-16	MAN®	E0834E/LE / E0836E	B4321	06.84.044	6 in.	5 kΩ	180°	10 in.	7
06.85.839H-16	MAN®	E0834E/LE / E0836E	GK3-5/RC78PYP	06.84.044	6 in.	5 kΩ	180°	10 in.	7
06.85.988-18	MAN®	E0834E/LE / E0836E	GK3-5/RC78PYP	06.84.044	6 in.	5 kΩ	180°	10 in.	1A

<sup>1)</sup> For 0 kΩ resistance, please add “-0” to part number (e.g. 06.85.908-22-0).

<sup>2)</sup> Other lengths in 2 in. increments available on request. For loose connector and 36 in. length add “-K” to part number (e.g. 06.85.908-K)

# Spark Plug Leads & Extensions



## PolyMot™ Spark Plug Leads – for common Applications

P/N	Engine Make	Model	Spark Plug	P/N Silicone Seal Ring	Extension Length	Resistance <sup>1)</sup>	Lead Output from Extension	Wire Length <sup>2)</sup>	Ignition Coil Connection
06.85.1030-16	MAN®	E0836LE / E28 series	B4321	06.84.044	6 in.	5 kΩ	180°	10 in.	1
06.85.580H-18	MAN®	E0836LE / E28 series	GE3-5/RN79G	06.84.059	6 in.	5 kΩ	180°	12 in.	1
06.85.415H-16	MAN®	E0836LE / E28 series	GE3-5/RN79G	06.84.059	6 in.	5 kΩ	180°	10 in.	2
06.85.1049-16	MAN®	E0836LE / E28 series	B4321	06.84.044	5 in.	5 kΩ	180°	11 in.	2
06.85.1031-16	MAN®	E0836LE / E28 series	B4321	06.84.044	6 in.	5 kΩ	180°	10 in.	7
06.85.836H-16	MAN®	E0836LE / E28 series	GE3-5/RN79G	06.84.059	6 in.	5 kΩ	180°	10 in.	7
06.85.989-18	MAN®	E0836LE / E28 series	GE3-5/RN79G	06.84.059	6 in.	5 kΩ	180°	10 in.	1A
06.85.1038-20	MAN®	E26 series	B4321	06.84.044	11 in.	5 kΩ	180°	10 in.	7
06.85.929-20	MAN®	E26 series	GK3-5/RC78PYP	06.84.044	11 in.	5 kΩ	180°	10 in.	7
06.85.1005-24	MAN®	E28 series	GL3-5	06.84.040	7 in.	5 kΩ	180°	17 in.	1A
06.85.1050-18	MAN®	E32 series	B4321	06.84.044	8 in.	5 kΩ	180°	10 in.	1
06.85.1058-18	MAN®	E32 series	GE3-5/RN79G	06.84.059	8 in.	5 kΩ	180°	10 in.	2
06.85.1023-18	MAN®	E32 series	B4321	06.84.044	10 in.	5 kΩ	180°	13 in.	7
06.85.959-18	MAN®	E32 series	GE3-5/RN79G	06.84.059	10 in.	5 kΩ	180°	13 in.	7
06.85.1042-18	MAN®	E32 series	GL3-5	06.84.040	10 in.	5 kΩ	180°	10 in.	7
06.85.320H-18	MWM® / DEUTZ®	234 series	GE3-5/RN79G	06.84.059	6 in.	5 kΩ	90°	18 in.	1
06.85.310H-11	MWM® / DEUTZ®	616 series	GL3-3/RB75WPCC	06.84.040	9 in.	5 kΩ	90°	11 in.	1
06.85.179-20	MWM® / DEUTZ®	620 series	GL3-3/RB75WPCC	06.84.040	10 in.	5 kΩ	90°	20 in.	1
06.85.178-20	MWM® / DEUTZ®	620 series	GL3-3/RB75WPCC	06.84.040	10 in.	5 kΩ	90°	20 in.	2
06.85.998-20	MWM® / DEUTZ®	620 series	GL3-3/RB75WPCC	06.84.040	10 in.	5 kΩ	90°	20 in.	7
06.85.479	PERKINS®	4000 series	GI3-3/FB77WPCC	06.84.040	12 in.	5 kΩ	180°	13 in.	1
06.85.1052-24	SCANIA®	DC12	GK3-5/RC78PYP	06.84.121	11 in.	5 kΩ	90°	24 in.	7
06.85.271	WÄRTSILÄ®	25SG series	GE3-5/RN79G	06.84.059	17 in.	5 kΩ	90°	14 in.	4
06.85.272	WÄRTSILÄ®	25SG series	GI3-3/FB77WPCC	06.84.040	17 in.	5 kΩ	90°	14 in.	4

<sup>1)</sup> For 0 kΩ resistance, please add "-0" to part number (e.g. 06.85.908-22-0).

<sup>2)</sup> Other lengths in 2 in. increments available on request. For loose connector and 36 in. length add "-K" to part number (e.g. 06.85.908-K)



5A = ALTRONIC® style; 5B = BENDIX® style; 5C = MOTORTECH

# Spark Plug Leads & Extensions

## UNSHIELDED

PolyMot™ Spark Plug Leads – for common Applications

P/N	Engine Make	Model	Spark Plug	P/N Silicone Seal Ring	Extension Length	Resistance <sup>1)</sup>	Lead Output from Extension	Wire Length <sup>2)</sup>	Ignition Coil Connection
06.85.312	WÄRTSILÄ®	25SG series	GI3-3/FB77WPCC	06.84.040	16 in.	5 kΩ	90°	14 in.	4
06.85.281	WÄRTSILÄ®	28SG series	GI3-3/FB77WPCC	06.84.040	21 in.	5 kΩ	180°	14 in.	4
06.85.306-18	WAUKESHA®	VGf series	GI3-3/FB77WPCC	06.84.040	12 in.	5 kΩ	90°	18 in.	1
06.85.326-16	WAUKESHA®	VGf series	GI3-3/FB77WPCC	06.84.040	10 in.	5 kΩ	180°	6 in.	1
06.85.429-14	WAUKESHA®	VGf series	GI3-3/FB77WPCC	06.84.040	11 in.	5 kΩ	90°	14 in.	1
06.85.357-26	WAUKESHA®	VGf series	GI3-3/FB77WPCC	06.84.040	12 in.	5 kΩ	180°	14 in.	2
06.85.423-16	WAUKESHA®	VHP GL series	GT3-1/RM77N	06.84.040	11 in.	5 kΩ	90°	16 in.	1
06.85.739-16	WAUKESHA®	VHP GL series	GT3-1/RM77N	06.84.040	9 in.	5 kΩ	90°	16 in.	1
06.85.945-16	WAUKESHA®	VHP GL series	GT3-1/RM77N	06.84.040	9 in.	6 kΩ	90°	16 in.	6
06.85.649-16	WAUKESHA®	VHP GL series	GT3-1/RM77N	06.84.040	11 in.	5 kΩ	90°	24 in.	5A
06.85.422-16	WAUKESHA®	VHP GU series	GT3-1/RM77N	06.84.040	13 in.	5 kΩ	90°	16 in.	1
06.85.688-16	WAUKESHA®	VHP GU series	GI3-1/FB77WPCC	06.84.040	11 in.	5 kΩ	90°	16 in.	1
06.85.993-24	WAUKESHA®	VHP GU series	D14/D14N	06.84.077	13 in.	5 kΩ	90°	24 in.	1
06.85.699-16	WAUKESHA®	VHP GU/GSI series	M82N	06.84.040	12 in.	5 kΩ	90°	16 in.	1
06.85.705-16	WAUKESHA®	VHP GU/GSI series	GT3-1/RM77N	06.84.040	12 in.	5 kΩ	90°	16 in.	1
06.85.720-18	WAUKESHA®	VHP GU/GSI series	GT3-1/RM77N	06.84.040	12 in.	5 kΩ	90°	18 in.	1
06.85.894-18	WAUKESHA®	VHP GU/GSI series	GT3-1/RM77N	06.84.040	14 in.	6 kΩ	90°	18 in.	6
06.85.672H-22	WAUKESHA®	VHP GU/GSI series	GI3-3/FB77WPCC	06.84.040	14 in.	5 kΩ	90°	22 in.	5A
06.85.714-24	WAUKESHA®	VHP/AT series	GI3-3/FB77WPCC	06.84.040	18 in.	5 kΩ	90°	24 in.	1
06.85.678-24	WAUKESHA®	VSG series	GE3-5/RN79G	06.84.059	5 in.	5 kΩ	180°	18 in.	1
06.85.667-26	WHITESUPERIOR®	G825 series	GT3-1/RM77N	06.84.040	8 in.	5 kΩ	90°	24 in.	1
06.85.723-24	WHITESUPERIOR®	GTLB825	D16	06.81.005	6 in.	5 kΩ	90°	24 in.	1
06.85.999-14	WORTHINGTON®	MLV (Centre Spark Plug)	RW80N	06.84.040	15 in.	5 kΩ	90°	14 in.	5A
06.85.1000-14	WORTHINGTON®	MLV (Side Spark Plug)	RW80N	06.84.040	22 in.	5 kΩ	90°	14 in.	5A
06.85.913-30	WORTHINGTON®	MLV10 (Centre Spark Plug)	RW82P	06.84.040	20 in.	5 kΩ	90°	30 in.	5A
06.85.912-24	WORTHINGTON®	MLV10 (Side Spark Plug)	GK3-5/RC78PYP	06.84.044	17 in.	5 kΩ	90°	24 in.	5A
06.85.1063-14	WORTHINGTON®	MLV14	RW80N	06.84.040	18 in.	5 kΩ	90°	14 in.	5A

<sup>1)</sup> For 0 kΩ resistance, please add „-0“ to part number (e.g. 06.85.908-22-0).

<sup>2)</sup> Other lengths in 2 in. increments available on request. For loose connector and 36 in. length add „-K“ to part number (e.g. 06.85.908-K).

### Ignition Coil Connections



5A = ALTRONIC® style; 5B = BENDIX® style; 5C = MOTORTECH

# Spark Plug Leads & Extensions



## Silicone Seal Rings for PolyMot™ Spark Plug Leads <sup>1)</sup>

P/N	Description	Fits Spark Plug <sup>2)</sup>	Dimensions	Quantity	Equivalent to
06.84.033-100	Silicone seal ring	GK3-5, RC78PYP, B4321	10.0 x 5.0 mm	100 pcs.	
06.84.034-100	Silicone seal ring	GI3-1, FB77WPCC, B8324	12.0 x 4.0 mm	100 pcs.	
06.84.038-100	Silicone seal ring	RW80N	14.4 x 2.8 mm	100 pcs.	
06.84.040-100	Silicone seal ring	GI3-1, FB77WPCC, B8324	14.6 x 2.7 mm	100 pcs.	
06.84.044-100	Silicone seal ring	GK3-5, RC78PYP, B4321	10.0 x 5.0 mm	100 pcs.	
06.84.059-100	Silicone seal ring	GE3-5, RN79G	11.0 x 4.0 mm	100 pcs.	
06.84.077-100	Silicone seal ring	D14, D14N	13.5 x 4.0 mm	100 pcs.	
06.84.121-100	Silicone seal ring	GK3-5, RC78PYP, B4321	10.0 x 3.0 mm	100 pcs.	

<sup>1)</sup> Silicone seal rings require replacement every 3000 running hours. See MOTORTECH homepage for appropriate instruction for replacing silicone seal rings.

<sup>2)</sup> Information provided only for comparison purposes.

## Installation Tool for WAUKESHA® Grommet

P/N	Description	Equivalent to
07.99.016	Installation tool for WAUKESHA® VHP grommet	



## Flange Kit for Spark Plug Leads for WAUKESHA® VHP/AT and CATERPILLAR® G3500 Series Gas Engines

P/N	Description	Equivalent to
06.51.248	Flange kit for use with P/N 06.85.714-L, P/N 06.85.594-L and P/N 06.85.954-L	



## Spark Plug Leads for CATERPILLAR® G3300 & G3400 Series Gas Engines

P/N	Supersedes	Engine Make	Model	Spark Plug	P/N Silicone Seal Ring	Extension Length	Resistance <sup>1)</sup>	Lead Output from Extension	Wire Length <sup>2)</sup>	Ignition Coil Connection
06.88.009-16 <sup>3)</sup>		CATERPILLAR®	G3300 series	GE3-5/RN79G	06.84.059	3.75 in.	1 kΩ	180°	12 in.	1
06.88.010-16		CATERPILLAR®	G3300 series	GE3-5/RN79G	06.84.059	4.25 in.	0 kΩ	180°	12 in.	2
06.85.751-18 <sup>4)</sup>	06.88.003-L/-K, 06.85.687-L	CATERPILLAR®	G3400 series	GE3-5/RN79G	06.84.059	13.00 in.	6 kΩ	90°	18 in.	1
06.85.1054-18		CATERPILLAR®	G3400 series	B4321	06.84.044	13.00 in.	5 kΩ	90°	18 in.	1
06.85.1019-16		CATERPILLAR®	G3400 series	GE3-5/RN79G	06.84.059	13 in.	6 kΩ	90°	18 in.	6
06.85.939-18		CATERPILLAR®	G3400 series	GE3-5/RN79G	06.84.059	13.00 in.	5 kΩ	90°	18 in.	5A

<sup>1)</sup> For 0 kΩ resistance, please add „-0“ to part number (e.g. 06.85.939-18-0).

<sup>2)</sup> Other lengths in 2 in. increments available on request. For loose connector and 36 in. length add „-K“ to part number (e.g. 06.85.751-K).

<sup>3)</sup> P/N 06.88.009-16 equivalent to P/N 7W-2479.

<sup>4)</sup> P/N 06.85.751-18 equivalent to P/N 7W-8542, 262-4855, 250-2149.

# Spark Plug Leads & Extensions

## UNSHIELDED

Spark Plug Leads – for common Applications (Non PolyMot™ Style)

P/N	Engine Make	Model	Spark Plug	P/N Silicone Seal Ring	Extension Length	Resistance <sup>1)</sup>	Lead Output from Extension	Wire Length <sup>2)</sup>	Ignition Coil Connection
06.85.773-15	AJAX®	230	GT3-1/RM77N	06.84.034	5 in.	0 kΩ	90°	15 in.	5A
06.85.719-16	AJAX®	230	W18	06.81.017	5 in.	1 kΩ	90°	16 in.	1
06.85.697-20	AJAX®	230	GT3-1/RM77N	06.84.040	5 in.	1 kΩ	90°	20 in.	1
06.85.698-30	AJAX®	230	GT3-1/RM77N	06.84.040	5 in.	0 kΩ	90°	30 in.	5A
06.85.860-16	ARROW®	VRG176/VRG220/ VRG330	J6C / J8C	06.84.059	5 in.	1 kΩ	90°	14 in.	6
06.85.514-16	CLARK®	TLA-6	RW80N	06.84.038	8 in.	0 kΩ	90°	16 in.	5A
06.85.1046-16 <sup>4)</sup>	CUMMINS®	G/GTA 5.9	GK3-5/RC78PYP		4 in.	0 kΩ	180°	12 in.	8
06.85.903-22 <sup>3)</sup>	CUMMINS®	GTA 8.3	GK3-5/RC78PYP		5 in.	5 kΩ	180°	17 in.	8
06.85.1062-16	CUMMINS®	ISL G280	GK3-5/RC78PYP	06.84.121	6 in.	5 kΩ	180°	10 in.	7
06.85.949-10	DEUTZ®	2015 series	B4321/14GZ6-77-2	06.84.033	9 in.	6 kΩ	90°	10 in.	6
06.88.015-48	INGERSOLL RAND®	KVSR12	RW80N	06.84.040	4 in.	0 kΩ	180°	14 in.	5A
06.85.1044-27	INGERSOLL RAND®	TVR10	RW83F	06.84.040	4 in.	0 kΩ	180°	23 in.	5A
06.85.964-20	LIEBHERR®	G9408	GK3-5/RC78PYP	06.81.071	6 in.	5 kΩ	180°	14 in.	2
06.85.697-20	WAUKESHA®	F1197G	GT3-1/RM77N	06.84.040	5 in.	1 kΩ	90°	20 in.	1
06.85.690-24	WHITE SUPERIOR®	G825 series	GK3-5/RC78PYP	06.84.044	8 in.	1 kΩ	90°	24 in.	1
06.85.695-24	WHITE SUPERIOR®	G825 series	D14N	06.84.040	8 in.	0 kΩ	90°	24 in.	5A
06.85.689-24	WHITE SUPERIOR®	G825 series (Lean Burn)	GK3-5/RC78PYP	06.84.044	4 in.	1 kΩ	90°	24 in.	1

<sup>1)</sup> For 0 kΩ resistance, please add „-0“ to part number (e.g. 06.85.949-10-0).

<sup>2)</sup> Other lengths in 2 in. increments available on request. For loose connector and 36 in. length add „-K“ to part number (e.g. 06.85.697-K).

<sup>3)</sup> P/N 06.85.903-22 equivalent to P/N 4989132.

<sup>4)</sup> P/N 06.85.1046-16 equivalent to P/N 4090567 and P/N 26354.

## Spark Plug Lead Kits

P/N	Engine Make	Model	Spark Plug	Number of included Leads	Extension Length	Resistance <sup>1)</sup>	Lead Output from Extension	Ignition Coil Connection
06.85.1006	ARROW®	VR330CF	GE3-5/RN79G	6	5 in.	5 kΩ	180°	6
06.85.952 <sup>1)</sup>	GM®	V8	GK3-5/RC78PYP	8	4 in.	0 kΩ	180°	4
06.85.379 <sup>2)</sup>	MAN®	E2866E302	GE3-5/RN79G	6	5 in.	5 kΩ	180°	6
06.85.380 <sup>2)</sup>	MAN®	E2842E302	GE3-5/RN79G	12	5 in.	5 kΩ	180°	6

<sup>1)</sup> Spark plug lead kit includes connecting leads from ignition coil to distributor.

<sup>2)</sup> Spark plug lead kits include distributor caps and connecting leads from ignition coil to distributor

## Ignition Coil Connections



5A = ALTRONIC® style; 5B = BENDIX® style; 5C = MOTORTECH



# Spark Plug Leads & Extensions



## Unshielded Safety Leads for Shielded Spark Plugs

P/N <sup>1)</sup>	SP Termination Well Depth	Spark Plug End	Ignition Coil End	Inductive Pickup Spacer	5 kΩ Resistor	Ignition Coil	Equivalent to
09.02.1000-L	2.125 in.	180°	180°			291001-S, 501061-S, 591010-S	USL2A-“L”A / AWH81-“L”
09.02.1001-L	2.125 in.	90°	180°			291001-S, 501061-S, 591010-S	USL2LA-“L”A
09.02.1010-L	2.125 in.	180°	90°			291001-S, 501061-S, 591010-S	USL2AL-“L”A
09.02.1011-L	2.125 in.	90°	90°			291001-S, 501061-S, 591010-S	USL2LAL-“L”A
09.02.1100-L	2.125 in.	180°	180°	x		291001-S, 501061-S, 591010-S	USL2A-“L”AIPS
09.02.1101-L	2.125 in.	90°	180°	x		291001-S, 501061-S, 591010-S	USL2LA-“L”AIPS
09.02.1110-L	2.125 in.	180°	90°	x		291001-S, 501061-S, 591010-S	USL2AL-“L”AIPS
09.02.1111-L	2.125 in.	90°	90°	x		291001-S, 501061-S, 591010-S	USL2LAL-“L”AIPS
09.02.1200-L	2.125 in.	180°	180°		x	291001-S, 501061-S, 591010-S	RSL2A-“L”A
09.02.1201-L	2.125 in.	90°	180°		x	291001-S, 501061-S, 591010-S	RSL2LA-“L”A
09.02.1210-L	2.125 in.	180°	90°		x	291001-S, 501061-S, 591010-S	RSL2AL-“L”A
09.02.1211-L	2.125 in.	90°	90°		x	291001-S, 501061-S, 591010-S	RSL2LAL-“L”A
09.02.1300-L	2.125 in.	180°	180°	x	x	291001-S, 501061-S, 591010-S	RSL2A-“L”AIPS
09.02.1301-L	2.125 in.	90°	180°	x	x	291001-S, 501061-S, 591010-S	RSL2LA-“L”AIPS
09.02.1310-L	2.125 in.	180°	90°	x	x	291001-S, 501061-S, 591010-S	RSL2AL-“L”AIPS
09.02.1311-L	2.125 in.	90°	90°	x	x	291001-S, 501061-S, 591010-S	RSL2LAL-“L”AIPS
09.02.2000-L	2.125 in.	180°	180°			10-320790-1, 10-382040-1	USL2B-“L”A / AWH22-“L”
09.02.2001-L	2.125 in.	90°	180°			10-320790-1, 10-382040-1	USL2LB-“L”A
09.02.2010-L	2.125 in.	180°	90°			10-320790-1, 10-382040-1	USL2BL-“L”A
09.02.2011-L	2.125 in.	90°	90°			10-320790-1, 10-382040-1	USL2LBL-“L”A
09.02.2100-L	2.125 in.	180°	180°	x		10-320790-1, 10-382040-1	USL2B-“L”AIPS
09.02.2101-L	2.125 in.	90°	180°	x		10-320790-1, 10-382040-1	USL2LB-“L”AIPS
09.02.2110-L	2.125 in.	180°	90°	x		10-320790-1, 10-382040-1	USL2BL-“L”AIPS
09.02.2111-L	2.125 in.	90°	90°	x		10-320790-1, 10-382040-1	USL2LBL-“L”AIPS
09.02.2200-L	2.125 in.	180°	180°		x	10-320790-1, 10-382040-1	RSL2B-“L”A
09.02.2201-L	2.125 in.	90°	180°		x	10-320790-1, 10-382040-1	RSL2LB-“L”A
09.02.2210-L	2.125 in.	180°	90°		x	10-320790-1, 10-382040-1	RSL2BL-“L”A
09.02.2211-L	2.125 in.	90°	90°		x	10-320790-1, 10-382040-1	RSL2LBL-“L”A
09.02.2300-L	2.125 in.	180°	180°	x	x	10-320790-1, 10-382040-1	RSL2B-“L”AIPS
09.02.2301-L	2.125 in.	90°	180°	x	x	10-320790-1, 10-382040-1	RSL2LB-“L”AIPS
09.02.2310-L	2.125 in.	90°	90°	x	x	10-320790-1, 10-382040-1	RSL2LBL-“L”AIPS
09.02.2311-L	2.125 in.	180°	90°	x	x	10-320790-1, 10-382040-1	RSL2BL-“L”AIPS
09.02.3000-L	2.125 in.	180°	180°			PPT2477AD, PPT2477AD-L	USL2C-“L”A / AWH42-“L”

<sup>1)</sup> „-L“ can be any lead length from 8 in. to 36 in. in 2 in. increments. Consult factory for other configurations.

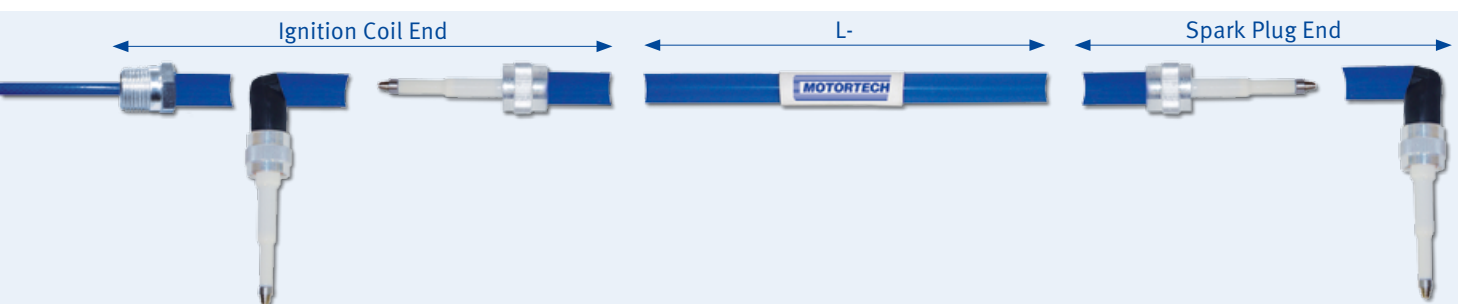

# ■ Spark Plug Leads & Extensions

## Unshielded Safety Leads for Shielded Spark Plugs

P/N <sup>1)</sup>	SP Termination Well Depth	Spark Plug End	Ignition Coil End	Inductive Pickup Spacer	5 kΩ Resistor	Ignition Coil	Equivalent to
09.02.3010-L	2.125 in.	180°	90°			PPT2477AD, PPT2477AD-L	USL2CL-“L“A
09.02.3011-L	2.125 in.	90°	90°			PPT2477AD, PPT2477AD-L	USL2LCL-“L“A
09.02.3100-L	2.125 in.	180°	180°	x		PPT2477AD, PPT2477AD-L	USL2C-“L“AIPS
09.02.3101-L	2.125 in.	90°	180°	x		PPT2477AD, PPT2477AD-L	USL2LC-“L“AIPS
09.02.3110-L	2.125 in.	180°	90°	x		PPT2477AD, PPT2477AD-L	USL2CL-“L“AIPS
09.02.3111-L	2.125 in.	90°	90°	x		PPT2477AD, PPT2477AD-L	USL2LCL-“L“AIPS
09.02.3200-L	2.125 in.	180°	180°		x	PPT2477AD, PPT2477AD-L	RSL2C-“L“A
09.02.3201-L	2.125 in.	90°	180°		x	PPT2477AD, PPT2477AD-L	RSL2LC-“L“A
09.02.3210-L	2.125 in.	180°	90°		x	PPT2477AD, PPT2477AD-L	RSL2CL-“L“A
09.02.3211-L	2.125 in.	90°	90°		x	PPT2477AD, PPT2477AD-L	RSL2LCL-“L“A
09.02.3300-L	2.125 in.	180°	180°	x	x	PPT2477AD, PPT2477AD-L	RSL2C-“L“AIPS
09.02.3301-L	2.125 in.	90°	180°	x	x	PPT2477AD, PPT2477AD-L	RSL2LC-“L“AIPS
09.02.3310-L	2.125 in.	180°	90°	x	x	PPT2477AD, PPT2477AD-L	RSL2CL-“L“AIPS
09.02.3311-L	2.125 in.	90°	90°	x	x	PPT2477AD, PPT2477AD-L	RSL2LCL-“L“AIPS
09.02.4000-L	2.125 in.	180°	180°			291001, 501061, 591010	USL2E-“L“A / AWH72-“L“
09.02.4001-L	2.125 in.	90°	180°			291001, 501061, 591010	USL2LE-“L“A
09.02.4100-L	2.125 in.	180°	180°	x		291001, 501061, 591010	USL2E-“L“AIPS
09.02.4101-L	2.125 in.	90°	180°	x		291001, 501061, 591010	USL2LE-“L“AIPS
09.02.4110-L	2.125 in.	180°	180°	x		291001, 501061, 591010	USL2E-“L“A w. 06.80.030
09.02.4200-L	2.125 in.	180°	180°		x	291001, 501061, 591010	RSL2E-“L“A
09.02.4201-L	2.125 in.	90°	180°		x	291001, 501061, 591010	RSL2LE-“L“A
09.02.4300-L	2.125 in.	180°	180°	x	x	291001, 501061, 591010	RSL2E-“L“AIPS
09.02.4301-L	2.125 in.	90°	180°	x	x	291001, 501061, 591010	RSL2LE-“L“AIPS
09.02.5000-L	2.125 in.	180°	180°			PPT2477P, PPT2477L	USL2F-“L“A / AWH82-“L“
09.02.5001-L	2.125 in.	90°	180°			PPT2477P, PPT2477L	USL2LF-“L“A
09.02.5100-L	2.125 in.	180°	180°	x		PPT2477P, PPT2477L	USL2F-“L“AIPS
09.02.5101-L	2.125 in.	90°	180°	x		PPT2477P, PPT2477L	USL2LF-“L“AIPS
09.02.5200-L	2.125 in.	180°	180°		x	PPT2477P, PPT2477L	RSL2F-“L“A
09.02.5201-L	2.125 in.	90°	180°		x	PPT2477P, PPT2477L	RSL2LF-“L“A
09.02.5300-L	2.125 in.	180°	180°	x	x	PPT2477P, PPT2477L	RSL2F-“L“AIPS
09.02.5301-L	2.125 in.	90°	180°	x	x	PPT2477P, PPT2477L	RSL2LF-“L“AIPS
09.02.7000-L	2.125 in.	180°	180°			Unshielded in Coil Box inst.	USL2G-“L“A / AWH62-“L“
09.02.7001-L	2.125 in.	90°	180°			Unshielded in Coil Box inst.	USL2LG-“L“A
09.02.7100-L	2.125 in.	180°	180°	x		Unshielded in Coil Box inst.	USL2G-“L“AIPS
09.02.7101-L	2.125 in.	90°	180°	x		Unshielded in Coil Box inst.	USL2LG-“L“AIPS
09.02.7200-L	2.125 in.	180°	180°		x	Unshielded in Coil Box inst.	RSL2G-“L“A
09.02.7201-L	2.125 in.	90°	180°		x	Unshielded in Coil Box inst.	RSL2LG-“L“A
09.02.7300-L	2.125 in.	180°	180°	x	x	Unshielded in Coil Box inst.	RSL2G-“L“AIPS
09.02.7301-L	2.125 in.	90°	180°	x	x	Unshielded in Coil Box inst.	RSL2LG-“L“AIPS

<sup>1)</sup> „L“ can be any lead length from 8 in. to 36 in. in 2 in. increments. Consult factory for other configurations.

# Spark Plug Leads & Extensions



## Unshielded Safety Leads for Conventional Spark Plugs

P/N <sup>1)</sup>	Fits max. Ceramic Diameter	Spark Plug End	Ignition Coil End	Inductive Pickup Spacer	5 kΩ Resistor	Ignition Coil	Equivalent to
09.03.1000-L	0.485 in.	180°	180°			291001-S, 501061-S, 591010-S	USLA14SPB-"L"A
09.03.4000-L	0.485 in.	180°	180°			291001, 501061, 591010	USLE14SPB-"L"A
09.04.1000-L	0.560 in.	180°	180°			291001-S, 501061-S, 591010-S	USLA18SPB-"L"A
09.04.4000-L	0.560 in.	180°	180°			291001, 501061, 591010	USLE18SPB-"L"A
09.05.1000-L	0.485 in.	180°	180°			291001-S, 501061-S, 591010-S	USLA35SPB-"L"A
09.05.4000-L	0.485 in.	180°	180°			291001, 501061, 591010	USLE35SPB-"L"A
09.06.1000-L	0.545 in.	180°	180°			291001-S, 501061-S, 591010-S	USLA36SPB-"L"A
09.06.4000-L	0.545 in.	180°	180°			291001, 501061, 591010	USLE36SPB-"L"A
09.07.1000-L	0.385 in.	180°	180°			291001-S, 501061-S, 591010-S	USLA45SPB-"L"A
09.07.4000-L	0.385 in.	180°	180°			291001, 501061, 591010	USLE45SPB-"L"A
09.08.1000-L	0.470 in.	180°	180°			291001-S, 501061-S, 591010-S	USLA51SPB-"L"A
09.08.4000-L	0.470 in.	180°	180°			291001, 501061, 591010	USLE51SPB-"L"A
09.09.1000-L	0.580 in.	180°	180°			291001-S, 501061-S, 591010-S	USLA78SPB-"L"A
09.09.2000-L	0.580 in.	180°	180°			10-320790-1, 10-382040-1	USLB78SPB-"L"A
09.09.4000-L	0.580 in.	180°	180°			291001, 501061, 591010	USLE78SPB-"L"A
09.10.1000-L	Silicone Boot	180°	180°			291001-S, 501061-S, 591010-S	USLASB180-"L"A
09.10.2000-L	Silicone Boot	180°	180°			10-320790-1, 10-382040-1	USLBSB180-"L"A
09.10.3000-L	Silicone Boot	180°	180°			PPT2477AD, PPT2477ADL	USLCSB180-"L"A
09.10.4000-L	Silicone Boot	180°	180°			291001, 501061, 591010	USLESB180-"L"A
09.11.1000-L	Silicone Boot	90°	180°			291001-S, 501061-S, 591010-S	USLASL90-"L"A
09.11.2000-L	Silicone Boot	90°	180°			10-320790-1, 10-382040-1	USLBSL90-"L"A
09.11.3000-L	Silicone Boot	90°	180°			PPT2477AD, PPT2477ADL	USLCSL90-"L"A
09.11.4000-L	Silicone Boot	90°	180°			291001, 501061, 591010	USLESL90-"L"A
09.12.1000-L	Terminal	90°	180°			291001-S, 501061-S, 591010-S	USLA18T22-"L"A
09.12.2000-L	Terminal	90°	180°			10-320790-1, 10-382040-1	USLB18T22-"L"A
09.12.3000-L	Terminal	90°	180°			PPT2477AD, PPT2477ADL	USLC18T22-"L"A
09.12.4000-L	Terminal	90°	180°			291001, 501061, 591010	USLE18T22-"L"A
09.13.1000-L	Terminal	180°	180°			291001-S, 501061-S, 591010-S	USLA18T33-"L"A
09.13.2000-L	Terminal	180°	180°			10-320790-1, 10-382040-1	USLB18T33-"L"A
09.13.3000-L	Terminal	180°	180°			PPT2477AD, PPT2477ADL	USLC18T33-"L"A
09.13.4000-L	Terminal	180°	180°			291001, 501061, 591010	USLE18T33-"L"A

<sup>1)</sup> „L“ can be any lead length from 8 in. to 36 in. in 2 in. increments.  
Consult factory for other configurations.

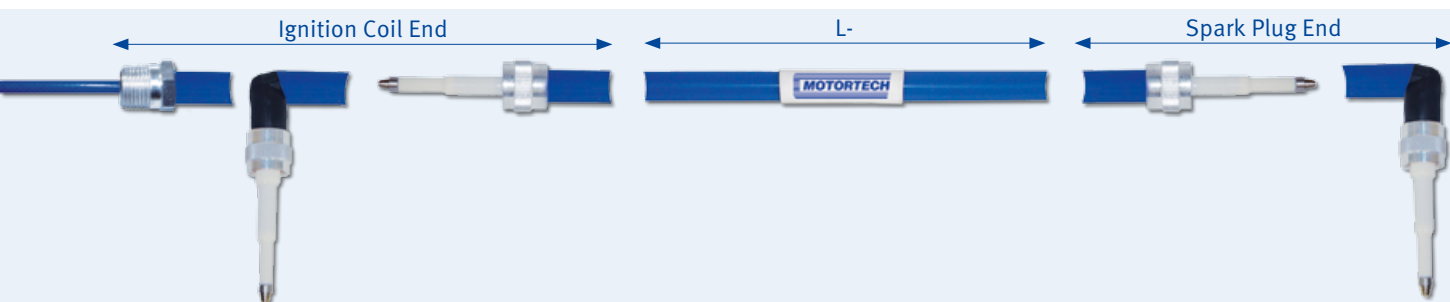

Conversion: 1 inch = 25,4 mm / 1 foot = 0,3 m

Ignition Systems

# ■ Spark Plug Leads & Extensions

## Accessories for Unshielded Spark Plug Leads

### Ignition Cables – Nickel Plated Copper Wire

P/N	Figure	Description	Color	Equivalent to
02.85.757	1	Ignition cable, 7 mm silicone, 17-19 stends, 100 ft. spool	blue	5419-100
02.85.758 <sup>1)</sup>	2	Ignition cable, 7 mm silicone, 17-19 stends, 100 ft. spool	orange	757, 5419-151

<sup>1)</sup>Ignition cable with stainless steel wire available on special request.

### Silicone Hoses

P/N	Figure	Description	Outer Diameter	Color	Equivalent to
02.85.965-82	3	Silicone hose, 8x2 mm, 82 ft. spool	12 mm	blue	21606
02.85.865-82	3	Silicone hose, 8x2 mm, 82 ft. spool	12 mm	orange	
02.85.914-82	3	Silicone hose, 12x1.5 mm, 82 ft. spool	15 mm	blue	SO-5
02.85.814-82	3	Silicone hose, 12x1.5 mm, 82 ft. spool	15 mm	orange	

### Inductive Pickup Spacer

P/N	Figure	Description	Position	Quantity	Equivalent to
06.84.010-100	4	Inductive pickup spacer	end of lead	100 pcs.	
06.84.043-100	5	Inductive pickup spacer	middle of lead	100 pcs.	

### Spark Plug Connectors (for 14 mm Spark Plugs only)

P/N	Figure	Description	Quantity	Equivalent to
06.84.024-100	6	Spark plug connector, 90°, silicone, for use with 7 mm ignition cable, including terminal P/N 02.85.920	100 pcs.	ST-22XL
06.84.025-100	7	Spark plug connector, 180°, silicone, for use with 7 mm ignition cable, including terminal P/N 02.85.920	100 pcs.	ST-33XL



Conversion: 1 inch = 25,4 mm / 1 foot = 0,3 m

# Spark Plug Leads & Extensions



Ignition Systems

## Spark Plug Boots

P/N	Figure	Description	Quantity	Equivalent to
06.84.008-100	8	Spark plug boot, 90°, silicone, for use with 7 mm ignition cable and terminal P/N 22.85.803	100 pcs.	
06.84.009-100	9	Spark plug boot, 180°, silicone, for use with 7 mm ignition cable and terminal P/N 22.85.802	100 pcs.	W54883

## Terminals for Spark Plug Boots

P/N	Figure	Description	Quantity	Equivalent to
02.85.920-100	10	Terminal, for use with spark plug boot P/N 06.84.024 and P/N 06.84.025	100 pcs.	D-199
22.85.802-100	11	Terminal, for use with spark plug boot P/N 06.84.009	100 pcs.	
22.85.803-100	12	Terminal, for use with spark plug boot P/N 06.84.008	100 pcs.	5419-150

## Silicone Boot

P/N	Figure	Description	Quantity	Equivalent to
02.99.004-100	13	Silicone boot, 90°	100 pcs.	

## Spark Plug Connectors

P/N	Figure	Description	Quantity	Equivalent to
02.85.924-100	14	Spark plug connector, 90°, for use with 7 mm ignition cable	100 pcs.	T-22, 21459
02.85.925-100	15	Spark plug connector, 180°, for use with 7 mm ignition cable	100 pcs.	T-33, 21418

## Ignition Coil Connectors

P/N	Figure	Description	Quantity	Equivalent to
06.80.261-100	16	Ignition coil connector, 180°, 0 kΩ resistance, requires crimp terminal P/N 06.80.126	100 pcs.	
22.80.009-100	17	Ignition coil connector, 90°, 1 kΩ resistance, requires crimp terminal P/N 06.80.126	100 pcs.	
06.80.091-100 <sup>1)</sup>	18	Ignition coil connector, 180°, 0 kΩ resistance, requires crimp terminal P/N 06.80.126	100 pcs.	

<sup>1)</sup> For ignition coils with positive secondary termination.



# ■ Spark Plug Leads & Extensions

## Crimp Terminals

P/N	Figure	Description	Quantity	Equivalent to
06.80.012-100	1	Crimp terminal, 180°, for use with spreading adaptor P/N 02.85.1012	100 pcs.	
06.80.116-100	2	Crimp terminal, 90°, for use with MOTORTECH Style ignition coils	100 pcs.	
06.80.116-180-100	3	Crimp terminal, 180°, for use with New MOTORTECH Style ignition coils	100 pcs.	
06.80.108-100	4	Crimp terminal base, for use with crimp terminals P/N 06.80.116-100 and P/N 06.80.116-180-100	100 pcs.	
06.80.126-100	5	Crimp terminal base, for use ignition coil terminals P/N 06.80.261 and P/N 22.80.009	100 pcs.	

## Spreading Adaptor

P/N	Figure	Supersedes	Description	Quantity	Equivalent to
02.85.1012-100	6	02.85.1004-100	Spreading adaptor for ALTRONIC® Style ignition coils	100 pcs.	

## Distance Collars

P/N	Figure	Description	Quantity	Equivalent to
06.86.001-100	7	Distance collar, for use with 7 mm ignition cable	100 pcs.	
06.86.002-100	8	Distance collar, for use with 7 mm ignition cable	100 pcs.	
06.86.003-100	9	Distance collar, for use with 7 mm ignition cable	100 pcs.	
06.86.005-100	10	Distance collar, for use with 7 mm ignition cable	100 pcs.	



1



2



3



4



5



6

# Spark Plug Leads & Extensions



Ignition Systems

## Silicone Seal Rings for Spark Plug Leads<sup>1)</sup>

P/N	Figure	Description	Dimensions	Quantity	Equivalent to
06.84.033-100	11	Silicone seal ring	10.0 x 5.0 mm	100 pcs.	
06.84.034-100	11	Silicone seal ring	12.0 x 4.0 mm	100 pcs.	
06.84.038-100	11	Silicone seal ring	14.4 x 2.8 mm	100 pcs.	
06.84.040-100	11	Silicone seal ring	14.6 x 2.7 mm	100 pcs.	
06.84.044-100	11	Silicone seal ring	10.0 x 5.0 mm	100 pcs.	
06.84.059-100	11	Silicone seal ring	11.0 x 4.0 mm	100 pcs.	
06.84.077-100	11	Silicone seal ring	13.5 x 4.0 mm	100 pcs.	

<sup>1)</sup> Silicone seal rings require replacement every 3000 running hours. See MOTORTECH homepage for appropriate instruction for replacing silicone seal rings.

## Grommets for CUMMINS® Ignition Coils

P/N	Figure	Description	Color	Quantity	Equivalent to
06.84.048-100	12	Grommet, for use with CUMMINS® ignition coil P/N 3930027	orange	100 pcs.	3938860
06.84.053-100	13	Grommet, for use with CUMMINS® 8.3 ignition coil	black	100 pcs.	3973945

## Silicone Seals for ALTRONIC®, BG®, CUMMINS® and WAUKESHA® Spark Plug Extensions

P/N	Figure	Description	Color	Quantity	Equivalent to
06.84.047-100	14	Silicone seal, for 14 mm spark plug extension	orange	100 pcs.	
06.84.049-100	15	Silicone seal, for 18 mm spark plug extension	blue	100 pcs.	740011





# ■ Spark Plug Leads & Extensions

SHIELDED

## MOT-Blues

SHIELDED SPARK PLUG LEADS

### MOT-Blues Shielded Spark Plug Leads for Externally Mounted Ignition Coils

There is an alternative to the commonly failing conventional shielded spark plug leads. MOTORTECH has designed a CSA approved shielded spark plug lead for Class I, Division 2, Group D that will perform better than the industry standard. There is no need to convert to unshielded when you cannot keep the engine running with the conventional leads.

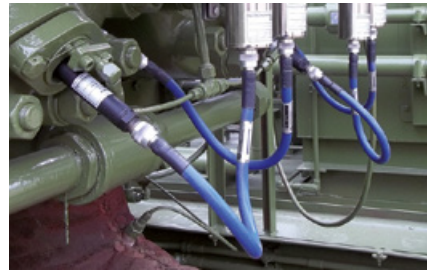

New Flex Style



Conventional Style



The MOT-Blues wire is specially designed for shielded CSA certified spark plug leads. It consists of a multi layer design:

- Nickel plated copper core
- 2 layers of silicone
- Stainless steel braid
- Silicone jacket

This design ensures that no humidity can be trapped in the lead.

# Spark Plug Leads & Extensions



## MOTORTECH Style – 1-20 UNEF Ignition Coil Termination

P/N <sup>1)</sup>	Description	Spark Plug Terminal Well Depth <sup>2)</sup>	Spark Plug Termination	Ignition Coil Termination	Equivalent to
95.91.020-L	MOT-Blues shielded spark plug lead	1 in.	3/4-20 UNEF, 180°	1-20 UNEF, 180°	A755-L, HT1400-L
95.91.030-L	MOT-Blues shielded spark plug lead	2 in.	3/4-20 UNEF, 180°	1-20 UNEF, 180°	A755-L-2, HT2400-L

<sup>1)</sup> Standard lead lengths = „L“ = 10 in., 13 in., 16 in., 18 in., 20 in., 21 in., 22 in., 24 in., 30 in., 35 in.; other lengths available on request.

<sup>2)</sup> Spark plug leads with 1 in. spark plug terminal well depth only available on special request.

All terminals made of ceramic. HEX-nut on spark plug side.



## ALTRONIC® Style – 3/4-20 UNEF Ignition Coil Termination

P/N <sup>1)</sup>	Description	Spark Plug Terminal Well Depth <sup>2)</sup>	Spark Plug Termination	Ignition Coil Termination	Equivalent to
95.90.020-L	MOT-Blues shielded spark plug lead	1 in.	3/4-20 UNEF, 180°	3/4-20 UNEF, 180°	593020-L, HT1300-L
95.90.030-L	MOT-Blues shielded spark plug lead	2 in.	3/4-20 UNEF, 180°	3/4-20 UNEF, 180°	593030-L, HT2300-L

<sup>1)</sup> Standard lead lengths = „L“ = 10 in., 13 in., 16 in., 18 in., 20 in., 21 in., 22 in., 24 in., 30 in., 35 in.; other lengths available on request.

<sup>2)</sup> Spark plug leads with 1 in. spark plug terminal well depth only available on special request.

All terminals made of ceramic. HEX-nut on spark plug side.



Ignition  
Systems

# ■ Spark Plug Leads & Extensions

## SHIELDED

### Conventional Shielded Spark Plug Leads for Externally Mounted Ignition Coils

#### MOTORTECH Style – 1-20 UNEF Ignition Coil Termination



P/N <sup>1)</sup>	Description	Spark Plug Terminal Well Depth <sup>2)</sup>	Spark Plug Termination	Ignition Coil Termination	Equivalent to
95.85.020-L	Shielded spark plug lead	1 in.	3/4-20 UNEF, 180°	1-20 UNEF, 180°	A755-L, HT1400-L
95.85.030-L	Shielded spark plug lead	2 in.	3/4-20 UNEF, 180°	1-20 UNEF, 180°	A755-L-2, HT2400-L

<sup>1)</sup> Standard lead lengths = „L“ = 10 in., 13 in., 16 in., 18 in., 20 in., 21 in., 22 in., 24 in., 30 in., 35 in.; other lengths available on request.

<sup>2)</sup> Spark plug leads with 1 in. spark plug terminal well depth only available on special request.

All terminals made of ceramic. HEX-nut on both sides.

#### ALTRONIC® Style – 3/4-20 UNEF Ignition Coil Termination



P/N <sup>1)</sup>	Description	Spark Plug Terminal Well Depth <sup>2)</sup>	Spark Plug Termination	Ignition Coil Termination	Equivalent to
95.80.020-L	Shielded spark plug lead	1 in.	3/4-20 UNEF, 180°	3/4-20 UNEF, 180°	593020-L, HT1300-L
95.80.030-L	Shielded spark plug lead	2 in.	3/4-20 UNEF, 180°	3/4-20 UNEF, 180°	593030-L, HT2300-L

<sup>1)</sup> Standard lead lengths = „L“ = 10 in., 13 in., 16 in., 18 in., 20 in., 21 in., 22 in., 24 in., 30 in., 35 in.; other lengths available on request.

<sup>2)</sup> Spark plug leads with 1 in. spark plug terminal well depth only available on special request.

All terminals made of ceramic. HEX-nut on both sides.

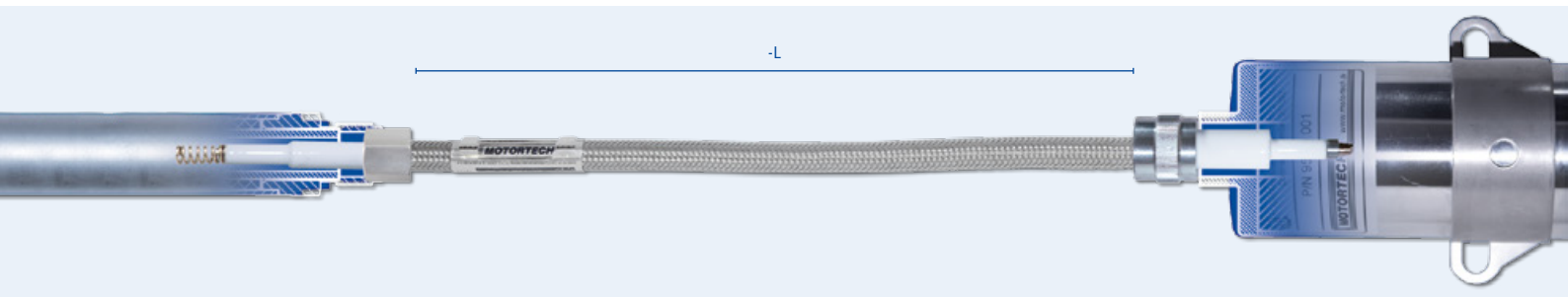

# Spark Plug Leads & Extensions



## Terminal Repair Kits for Shielded and Unshielded Spark Plug Leads

### Kits for MOT-Blues **Shielded** Spark Plug Leads

P/N	Description	Stud Thread Size	Adaptor	Equivalent to
02.85.1006	Terminal kit, spark plug sided	M3	3/4-20 UNEF, 2 in. terminal well depth <sup>1)</sup>	
02.85.1007	Terminal kit, ignition coil sided	M3	3/4-20 UNEF, ALTRONIC® Style	
02.85.1008	Terminal kit, ignition coil sided	M3	1-20 UNEF, MOTORTECH Style	

<sup>1)</sup> Consult factory for terminal kits to fit spark plugs with 3/4-20 UNEF thread and 1 in. terminal well depth.

### Kits for Conventional **Shielded** Spark Plug Leads

P/N	Description	Stud Thread Size	Adaptor	Equivalent to
02.85.991	Terminal kit, spark plug sided	M3	3/4-20 UNEF, 1 in. terminal well depth	
02.85.991-2	Terminal kit, spark plug sided	3/48 UNC	3/4-20 UNEF, 1 in. terminal well depth	SC1K, 504205
02.85.992	Terminal kit, spark plug sided	M3	3/4-20 UNEF, 2 in. terminal well depth	
02.85.992-2	Terminal kit, spark plug sided	3/48 UNC	3/4-20 UNEF, 2 in. terminal well depth	SC2K, 504137
02.85.979	Terminal kit, spark plug sided	3/48 UNC	3/4-20 UNEF, 1 in. terminal well depth	
02.85.992-1	Terminal kit, ignition coil sided	M3	3/4-20 UNEF, BENDIX® Style	
02.85.992-3	Terminal kit, ignition coil sided	3/48 UNC	3/4-20 UNEF, BENDIX® Style	
02.85.996	Terminal kit, ignition coil sided	M3	3/4-20 UNEF, ALTRONIC® Style	
02.85.996-2	Terminal kit, ignition coil sided	3/48 UNC	3/4-20 UNEF, ALTRONIC® Style	ALTSS-2
02.85.997	Terminal kit, ignition coil sided	M3	1-20 UNEF, MOTORTECH Style	
02.85.997-2	Terminal kit, ignition coil sided	3/48 UNC	1-20 UNEF, MOTORTECH Style	

### Kits for **Unshielded** Spark Plug Leads

P/N	Description	Stud Thread Size	Adaptor	Equivalent to
02.85.993	Terminal kit, ignition coil sided	M3	3/4-20 UNEF, ALTRONIC® Style	
02.85.993-2	Terminal kit, ignition coil sided	3/48 UNC	3/4-20 UNEF, ALTRONIC® Style	ALTOS-1, 510480
02.85.994	Terminal kit, ignition coil sided	M3	3/4-20 UNEF, BENDIX® Style	
02.85.994-2	Terminal kit, ignition coil sided	3/48 UNC	3/4-20 UNEF, BENDIX® Style	BENDOS-1
02.85.995	Terminal kit, ignition coil sided	M3	1-20 UNEF, MOTORTECH Style	
02.85.995-2	Terminal kit, ignition coil sided	3/48 UNC	1-20 UNEF, MOTORTECH Style	FMOS-1



# ■ Spark Plug Leads & Extensions

UNSHIELDED



## PolyMot™ Spark Plug Extensions

Besides all the successful spark plug leads, MOTORTECH has also designed a large number of spark plug extensions under the PolyMot™ design. These extensions are unique and offer several advantages when being compared to the OEM or aftermarket competition. With the knowledge gathered in ignition control and ignition coil research and manufacturing, a lot of the details were implemented into these products. The unique structure has achieved tremendous reliability records in the field.

### General Features

- Rigid design
- Extensions made of high quality TEFLON® and up to 36 in. length
- Ceramic insert with 5 kΩ resistor for EMI suppression (0 kΩ available on request)
- Reliable ignition coil and spark plug terminal
- Critical high voltage areas are protected with seals
- Designed to match the engine model, the spark plug type and application
- Extensions are labeled with P/N and production code for easy traceability
- Top thread for easy removal with special tool
- Long life product

### Key Design Features

- 1 Spring-loaded secondary terminal rod to ignition coil
- 2 Special O-ring made of VITON® with excellent temperature and aging characteristics for best protection of ignition coil secondary terminal
- 3 Large thread on top end for easy removal with special tool P/N 44.99.912
- 4 Highest dielectric strength due to TEFLON® insulator
- 5 Ceramic insert with 5 kΩ resistor for EMI suppression
- 6 Integrated silicone spark plug seal for best flashover protection will not stick on the spark plug insulator when pulling off the extension

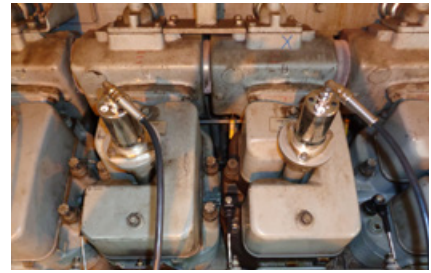

# Spark Plug Leads & Extensions



## PolyMot™ Spark Plug Extensions – for common Applications

P/N <sup>1)</sup>	Supersedes	Engine Make	Model	Extension Length	Resistance	Spark Plug	P/N Silicone Seal Ring	Thread on Top End	Equivalent to
06.80.320-T	06.80.320, 06.80.320H, 06.80.320H-T, 06.80.381H, 06.80.381H-T	CATERPILLAR®	G3500 series	11 in.	5 kΩ	GI3-3/ FB77WPCC/ B8324	06.84.040	x	123-4710, 25080-04, 5419-806
06.80.319-T	06.80.319, 06.80.319H, 06.80.319H-T	CATERPILLAR®	G3600 series	11 in.	5 kΩ	GI3-3/ FB77WPCC/ B8324	06.84.040	x	123-8641, 25080-03, 5419-805
06.80.202-T	06.80.202	COOPER®	2400G series	9 in.	5 kΩ	GI3-3/ FB77WPCC/ B8324	06.84.040		656-701-003, 25080-02, 5419-801
06.80.755-T <sup>2)</sup>		CUMMINS®	QSK60G	13 in.	5 kΩ	GI3-3/ FB77WPCC/ B8324	06.84.040	x	
06.80.756-T <sup>2)</sup>		CUMMINS®	QSV81/91G	15 in.	5 kΩ	GI3-3/ FB77WPCC/ B8324	06.84.040	x	
06.80.471-T		WAUKESHA®	275GL+ series	15 in.	5 kΩ	GI3-3/ FB77WPCC/ B8324	06.84.040	x	A296064J, A296064K, 26400-10, 26510-10
06.80.469-T		WAUKESHA®	APG series	10 in.	5 kΩ	GI3-3/ FB77WPCC/ B8324	06.84.040	x	A211797M, A211797T, 25080-10, 26400-08, 26510-08
06.80.206-T	06.80.206	WAUKESHA®	AT25GL series	15 in.	5 kΩ	GT3-1/ RM77N/ B8124	06.84.040	x	A211357L, A211357N, A211357T, A211357Y, A296805A, 26400-02, 26510-02, 5419-802
06.80.330-T	06.80.330	WAUKESHA®	AT25GL-LR series	15 in.	5 kΩ	GI3-3/ FB77WPCC/ B8324	06.84.040	x	A211357R, A211357V, A211357Z, A296805, 25080-08, 26400-04, 26510-04, 5419-808
06.80.213-T	06.80.213	WAUKESHA®	AT27GL series	15 in.	5 kΩ	GT3-1/ RM77N/ B8124	06.84.040	x	296064B, 296064C, A296064C, A296064E, A296064G, 25080-11, 26400-03, 26510-03
06.80.310-T	06.80.310	WAUKESHA®	AT27GL-LR series	14 in.	5 kΩ	GI3-3/ FB77WPCC/ B8324	06.84.040	x	296064D, 296064F, 296064H, A296064D, A296064F, A296064H, A296064L, 25080-07, 26400-05, 26510-05, 5419-804
06.80.309-T	06.80.309	WAUKESHA®	VGF series	9 in.	5 kΩ	GI3-3/ FB77WPCC/ B8324	06.84.040	x	A211357X, A211797J, A211797K, A211797S, 25080-01, 26400-07, 26510-07, 5419-803
06.80.340-T	06.80.340	WAUKESHA®	VHP-4 series	13 in.	5 kΩ	GI3-3/ FB77WPCC/ B8324	06.84.040	x	211797A, A211797G, 25080-06, 26510-06, 5419-735
06.80.321-T	06.80.321, 06.80.321H, 06.80.321H-T	WAUKESHA®	VHP-GL series	13 in.	5 kΩ	GI3-3/ FB77WPCC/ B8324	06.84.040	x	211357P, 211357U, A211797H, A211797R, A211797R, 25080-05, 25080-12, 26400-01, 26510-01, 5419-807

<sup>1)</sup> For 0 kΩ resistance, please add “-0” to part number (e.g. 06.80.320-T-0).

<sup>2)</sup> Fits application only, if conversion kits P/N 75.30.143 or 75.30.144 previously were used.

### Removal Tool for Spark Plug Extensions with Thread on Top End

P/N	Supersedes	Description	Equivalent to
44.99.912		Spark plug extension removal tool	



# ■ Spark Plug Leads & Extensions

## Ignition Coil Extensions

For **MOTORTECH/CATERPILLAR®** Ignition Coils – For CATERPILLAR® G3520C/E and G3600 Series Gas Engines

P/N	Figure	Description	Application	Resistance	Extension Length	Extension Diameter	Fits Ignition Coil P/N	Equivalent to
06.80.459H <sup>1)</sup>	1	Ignition coil extension	G3520C/E, G3600	0 kΩ	248 mm	26 mm	06.50.161, 06.50.162, 283-5270	308-1380, 283-5271, 264-5323, 150-2050
06.80.600	2	Ignition coil extension	G3520C/E, G3600	0 kΩ	252 mm	26 mm	06.50.164, 06.50.165	

<sup>1)</sup> Supersedes ignition coil extensions P/N 06.80.375H and 06.80.446H.

For **MOTORTECH/CATERPILLAR®** Ignition Coils – For CATERPILLAR® GCM34 Series Gas Engines

P/N	Figure	Description	Application	Resistance	Extension Length	Extension Diameter	Fits Ignition Coil P/N	Equivalent to
06.80.1013-T	3	Ignition coil extension	GCM34	5 kΩ	530 mm	26 mm	193-468157, 258-4893, 06.50.170	263210167, 3400.7-21.07.02-03
06.80.602	4	Ignition coil extension	GCM34	5 kΩ	534 mm	26 mm	06.50.174, 06.50.175	

For CATERPILLAR® Ignition Coils

P/N	Figure	Description	Extension Length	Extension Diameter	Equivalent to
06.80.356H	5	Ignition coil extension	118 mm	25 mm	133-5078
06.80.360H	5	Ignition coil extension	118 mm	30 mm	169-4295

For WÄRTSILÄ® 34SG and 220G/SG Gas Engines

P/N	Description	Application	Resistance	Extension Length	Extension Diameter	Fits Ignition Coil P/N	Equivalent to
06.80.460	Ignition coil extension	34SG series	5 kΩ	460 mm	26 mm		0012E002200
06.80.461	Ignition coil extension	34SG series	5 kΩ	446 mm	26 mm		0012E006500
06.80.145-1	Ignition coil extension	220G/SG series	5 kΩ	334 mm	24 mm		3340063
06.80.145-2	Ignition coil extension	220G/SG series	5 kΩ	329 mm	24 mm		3341380





# Spark Plug Leads & Extensions



## Ignition Coil Extension Overhaul Kits

For MOTORTECH Ignition Coils – For CATERPILLAR® G3400 and G3500 Series Gas Engines

P/N	Figure	Supersedes	Description	Application	Extension Length	Extension Diameter	Fits Ignition Coil P/N
06.80.741	6		Extension overhaul kit	G3400 – Non CSA	95 mm	30 mm	06.50.141, 06.50.145
06.80.742	6		Extension overhaul kit	G3400 – CSA	97 mm	30 mm	06.50.142, 06.50.146
06.80.743	6		Extension overhaul kit	G3400 – Non CSA	107 mm	30 mm	06.50.143, 06.50.147
06.80.744	6		Extension overhaul kit	G3400 – CSA	109 mm	30 mm	06.50.144, 06.50.148
06.80.751	6		Extension overhaul kit	G3500 – Non CSA	118 mm	30 mm	06.50.151, 06.50.155
06.80.752	6		Extension overhaul kit	G3500 – CSA	105 mm	30 mm	06.50.152, 06.50.156
06.80.753	6		Extension overhaul kit	G3500 – Non CSA	112 mm	30 mm	06.50.153, 06.50.157
06.80.754	6		Extension overhaul kit	G3500 – CSA	105 mm	30 mm	06.50.154, 06.50.158

Above Overhaul Kits contain following Subcomponents

P/N	P/N Extension including Seal	P/N included Spark Plug Seal	P/N included Extension Seal	P/N Lip Seal	P/N Secondary Terminal
06.80.741	06.80.741-2	06.84.059		06.81.051	02.85.881
06.80.742	06.80.742-2	06.84.059	06.81.084	06.81.051	06.51.134
06.80.743	06.80.743-2	06.84.059		06.81.051	06.51.136
06.80.744	06.80.744-2	06.84.059	06.81.084	06.81.051	06.51.133
06.80.751	06.80.751-2	06.84.040		06.81.051	02.85.881
06.80.752	06.80.752-2	06.84.040	06.81.084	06.81.051	02.85.870
06.80.753	06.80.753-2	06.84.040		06.81.051	02.85.881
06.80.754	06.80.754-2	06.84.040	06.81.084	06.81.051	02.85.870



6

# ■ Spark Plug Leads & Extensions

For CATERPILLAR® Ignition Coils – For CATERPILLAR® G3400 and G3500 Series Gas Engines

P/N	Figure	Supersedes	Description	Application	Extension Length	Extension Diameter	Fits Ignition Coil P/N
06.80.419H	1		Extension overhaul kit	G3400 – Non CSA	95 mm	30 mm	232-6348, 165-1591, 131-3277, 129-8802, 108-0615
06.80.742	1	06.80.418H	Extension overhaul kit	G3400 – CSA	97 mm	30 mm	232-6349, 165-1592, 122-8070
06.80.420H	1		Extension overhaul kit	G3400 – Non CSA	107 mm	30 mm	232-6352, 213-7443
06.80.744	1	06.80.417H	Extension overhaul kit	G3400 – CSA	109 mm	30 mm	232-6353, 213-7444
06.80.515H	1	06.80.315H	Extension overhaul kit	G3500 – Non CSA	118 mm	30 mm	232-6346, 165-1589, 124-0749
06.80.752	1	06.80.415H	Extension overhaul kit	G3500 – CSA	105 mm	30 mm	232-6347, 165-1590
06.80.480	1		Extension overhaul kit	G3500 – Non CSA	112 mm	30 mm	232-6350
06.80.754	1	06.80.415H	Extension overhaul kit	G3500 – CSA	105 mm	30 mm	259-2078

Above Overhaul Kits contain following Subcomponents

P/N	P/N Extension including Seal	P/N included Spark Plug Seal	P/N included Extension Seal	P/N Lip Seal	P/N Secondary Terminal
06.80.419H	06.80.279H	06.84.059		06.81.051	02.85.881
06.80.742	06.80.742-2	06.84.059	06.81.084	06.81.051	06.51.134
06.80.420H	06.80.280H	06.84.059		06.81.051	06.51.136
06.80.744	06.80.744-2	06.84.059	06.81.084	06.81.051	06.51.133
06.80.515H	06.80.335H-1	06.84.040		06.81.051	02.85.881
06.80.752	06.80.752-2	06.84.040	06.81.084	06.81.051	02.85.870
06.80.480	06.80.481	06.84.040		06.81.051	02.85.881
06.80.754	06.80.754-2	06.84.040	06.81.084	06.81.051	02.85.870

Extension Rods – Low Cost Style <sup>1)</sup>

P/N <sup>2)</sup>	Description	Primary Connection	Secondary Connection	Equivalent to
06.80.349-L	Teflon covered extension rod	SAE	snap-on attachment	TCRC-“L”
06.80.376-L	Teflon covered extension rod	SAE	#8-32 screw-on attachment	TCR-“L”
06.80.376-10	Teflon covered extension rod	SAE	#8-32 screw-on attachment	TCR-10WM / 207927A

<sup>1)</sup> We recommend using PolyMot™ spark plug leads.

<sup>2)</sup> Standard lengths („-L“) = 3 in., 4 in., 5 in., 6 in., 8 in., 10 in., 12 in., 14 in., 16 in., 18 in., 20 in., 24 in.; other lengths available on request.

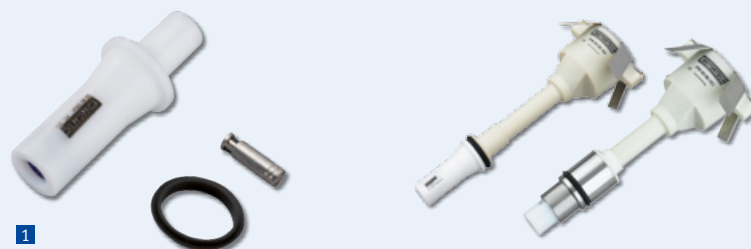

1

# Spark Plug Leads & Extensions



SHIELDED

## Extensions for Integral Ignition Coils to Shielded Spark Plugs



P/N <sup>1)</sup>	Figure	Description	Spark Plug Connection	Terminal Well Depth	Ignition Coil Connection	Terminal Well Depth	Equivalent to
95.07.010-L	1	Integral ignition coil extension	5/8-24 UNEF	1 in.	1-20 UNEF	2 in.	BG E Series
95.07.011-L	1	Integral ignition coil extension	3/4-20 UNEF	1 in.	1-20 UNEF	2 in.	593120-L, M"L"-2C
95.07.012-L	1	Integral ignition coil extension	3/4-20 UNEF	2 in.	1-20 UNEF	2 in.	593130-L, M"L"-1C
95.07.013-L	1	Integral ignition coil extension	13/16-20 UNEF	2 in.	1-20 UNEF	2 in.	593140-L

<sup>1)</sup> Standard lengths („-L“) = 1.5 in., 3 in., 6 in., 9 in., 11 in., 19 in.; other lengths available on request.

Ignition Systems

## Extensions for Shielded Spark Plugs to Shielded Secondary Leads



P/N <sup>1)</sup>	Figure	Description	Spark Plug Connection	Terminal Well Depth	Spark Plug Lead Connection	Terminal Well Depth	Equivalent to
95.07.020-L	2	Shielded spark plug extension	5/8-24 UNEF	1 in.	5/8-24 UNEF	1 in.	
95.07.021-L	2	Shielded spark plug extension	3/4-20 UNEF	1 in.	3/4-20 UNEF	1 in.	M"L"-2S
95.07.022-L	2	Shielded spark plug extension	3/4-20 UNEF	2 in.	3/4-20 UNEF	2 in.	M"L"-2E
95.07.023-L	2	Shielded spark plug extension	5/8-24 UNEF	1 in.	3/4-20 UNEF	2 in.	
95.07.024-L	2	Shielded spark plug extension	3/4-20 UNEF	1 in.	3/4-20 UNEF	2 in.	

<sup>1)</sup> Standard lengths („-L“) = 4 in., 5 in., 6 in., 8 in., 10 in., 12 in., 18 in.; other lengths available on request.



1



2



## ■ Spark Plug Leads & Extensions



A series of horizontal blue lines spanning the width of the page, providing a space for writing or notes.

# Ignition Wiring Rails & Hardware

SHIELDED

## AlphaRail

MOTORTECH WIRING RAIL SYSTEM

### Wiring Rail System for Ignition Control

MOTORTECH stainless steel, vibration resistant rail assembly will withstand any harsh environment commonly found in the oil & gas industry. The proven design is made for engine manufacturers and the global aftermarket.

Do not go Low-Tech and take the risk of engine down time because of equipment being under repair. Eliminate the need for constant rewiring, connector exchanges or straightening out weak and bent aluminum wiring rails.

- Made of stainless steel
- Rigid military style connectors
- Rails are filled with special foam to ensure that all wires are separated from ground and will not vibrate
- Water proof design – built to last in uncovered environment
- Repairable by MOTORTECH's assigned distributors in the event of mechanically damage
- Ignition rails can be used for shielded and unshielded applications.
- Due to base rail structure easy for stocking
- Quick service access with quick-disconnect connections

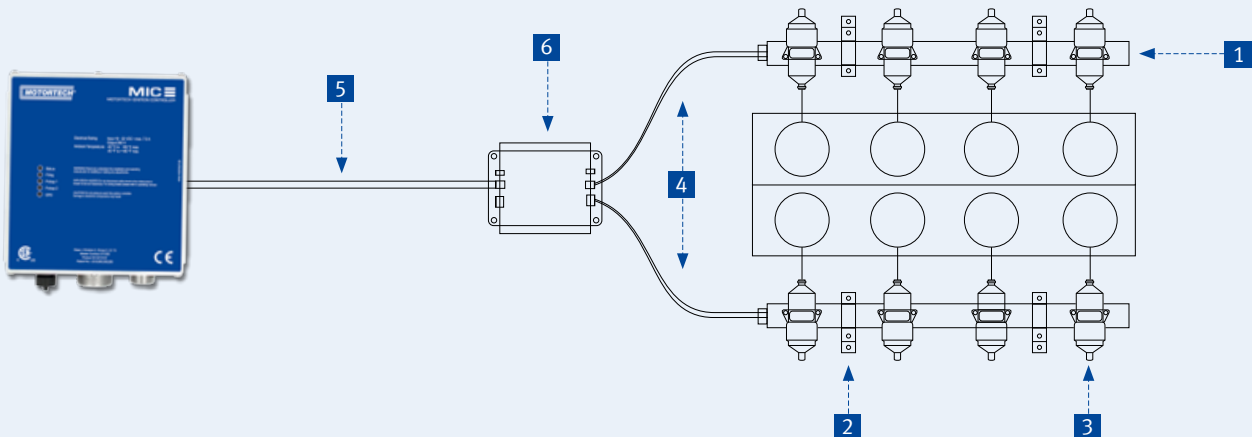
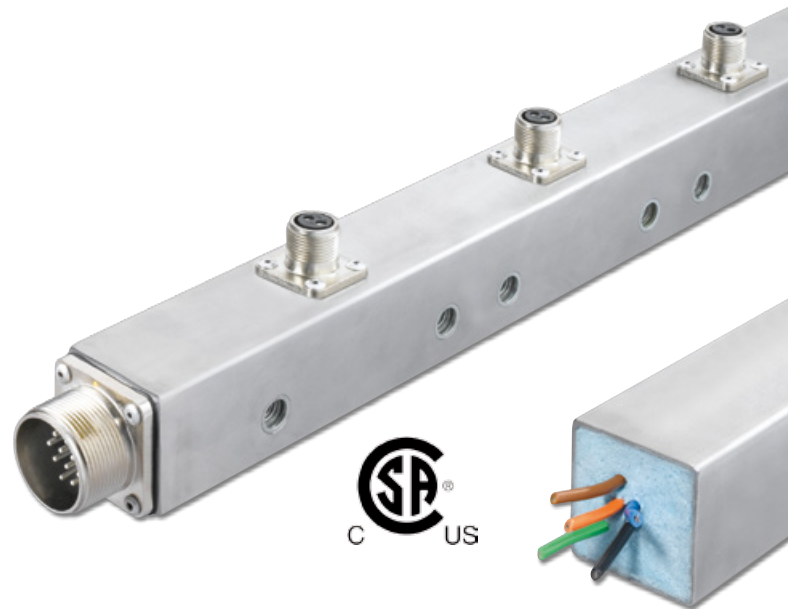
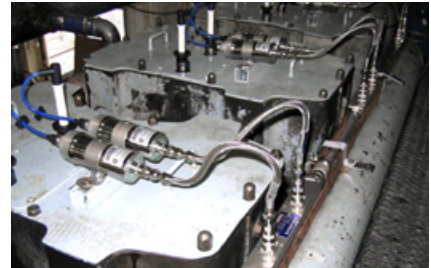

# Ignition Wiring Rails & Hardware



## 1 AlphaRail for Ignition Control – Specification Table

P/N 95.8 **A** **B** **C** **D** **E** **F** **G** **H** **J**

Ignition Systems

A	Ignition Coils per Cylinder
6	Engine with one ignition coil per cylinder
7	Engine with two ignition coils per cylinder <sup>1)</sup>

<sup>1)</sup> See “HJ” for distance between two ignition coils.

B	Number of Cylinders per Bank		
1	Special version	5	5 cylinders
2	2 cylinders	6	6 cylinders
3	3 cylinders	8	8 cylinders
4	4 cylinders	0	10 cylinders

CD	Distance between the Cylinders		
04	4 in.	12	12 in.
06	6 in.	13	13 in.
07	7 in.	14	14 in.
08	8 in.	16	16 in.
10	10 in.	27	27 in.
11	11 in.	33	33 in.

E	Ignition Coil Mounting
N	STANDARD – NO ignition coil mounted

F	Double Rail <sup>1)</sup> – Length of Flex Conduit		
A	NO Double Rail	E	24 in.
B	12 in.	F	32 in.
C	16 in.	G	40 in.
D	20 in.	H	52 in.

<sup>1)</sup> Two ignition wiring rails connected by flex conduit.

G	Specification of Ignition Coil
N	STANDARD – NO ignition coil mounted <sup>1)</sup>

<sup>1)</sup> Ignition coils have to be ordered separately (see page 28 – Ignition Coils)

HJ	Distance between two Ignition Coils – Only for two Ignition Coils per Cylinder		
04	4 in.	16	16 in.
06	6 in.	18	18 in.
08	8 in.	20	20 in.
10	10 in.	22	22 in.
12	12 in.	24	24 in.
14	14 in.		



# Ignition Wiring Rails & Hardware

## 1 AlphaRail for Ignition Control – Wiring Rails for common Applications <sup>1)</sup>

P/N	Description	Engine Make	Model	Required Quantity per Engine
95.86.406-NAN	AlphaRail wiring rail	CATERPILLAR®	G3304	1
95.86.606-NAN	AlphaRail wiring rail	CATERPILLAR®	G3306	1
95.86.607-NAN	AlphaRail wiring rail	CATERPILLAR®	G3406	1
95.86.407-NAN	AlphaRail wiring rail	CATERPILLAR®	G3408	2
95.86.607-NAN	AlphaRail wiring rail	CATERPILLAR®	G3412	2
95.86.411-NAN	AlphaRail wiring rail	CATERPILLAR®	G3508	2
95.86.611-NAN	AlphaRail wiring rail	CATERPILLAR®	G3512	2
95.86.811-NAN	AlphaRail wiring rail	CATERPILLAR®	G3516	2
95.87.631-NGN-08	AlphaRail wiring rail	CLARK®	HBA-6T	1
95.87.531-NAN-08	AlphaRail wiring rail	CLARK®	HBA-10T	2
95.87.637-NAN	AlphaRail wiring rail	CLARK®	TCVD-12	2
95.87.631-NGN-10	AlphaRail wiring rail	CLARK®	TLA-6T	1
95.87.544-NGN-06	AlphaRail wiring rail	COOPER®	GMVH-10	2
95.87.541-NGN-10	AlphaRail wiring rail	COOPER®	GMW-10	2
95.87.340-NAN	AlphaRail wiring rail	COOPER®	GMWC-6	2
95.87.822-NGN-06	AlphaRail wiring rail	COOPER®	LSV-16	2
95.87.633-NFN-22	AlphaRail wiring rail	INGERSOLL RAND®	KVR-412	2
95.87.344-NAN-04	AlphaRail wiring rail	INGERSOLL RAND®	KVS-6	2
95.86.427-NDN	AlphaRail wiring rail	INGERSOLL RAND®	PKVG-8	2
95.86.627-NDN	AlphaRail wiring rail	INGERSOLL RAND®	PKVG-12	2
95.86.627-NFN	AlphaRail wiring rail	INGERSOLL RAND®	PKVGR-12	2
95.86.437-NAN	AlphaRail wiring rail	INGERSOLL RAND®	XVG-8	2
95.86.606-NAN	AlphaRail wiring rail	WAUKESHA®	F817	1
95.86.614-NAN	AlphaRail wiring rail	WAUKESHA®	F1197GL/GU	1
95.86.608-NAN	AlphaRail wiring rail	WAUKESHA® VGF	F18	1
95.86.808-NAN	AlphaRail wiring rail	WAUKESHA® VGF	H24	1
95.86.609-NAN	AlphaRail wiring rail	WAUKESHA® VGF	L36	2
95.86.809-NAN	AlphaRail wiring rail	WAUKESHA® VGF	P48	2
95.86.614-NAN	AlphaRail wiring rail	WAUKESHA® VHP	F2895GL/GSI	1
95.86.614-NAN	AlphaRail wiring rail	WAUKESHA® VHP	F3521GSI	1
95.86.614-NAN	AlphaRail wiring rail	WAUKESHA® VHP	L5790GSI	2
95.86.614-NAN	AlphaRail wiring rail	WAUKESHA® VHP	L7042G/GL/GU/GSI	2
95.86.614-NAN	AlphaRail wiring rail	WAUKESHA® VHP	L7044GL/GSI	2
95.86.814-NFN	AlphaRail wiring rail	WAUKESHA® VHP	P9390GL/GSI	2
95.86.815-NAN	AlphaRail wiring rail	WAUKESHA®	8L-AT27GL	1
95.86.618-NAN	AlphaRail wiring rail	WAUKESHA®	12V-AT27GL	2
95.86.818-NAN	AlphaRail wiring rail	WAUKESHA®	16V-AT27GL	2
95.86.814-NAN	AlphaRail wiring rail	WHITE SUPERIOR®	2408G	1
95.86.613-NAN	AlphaRail wiring rail	WHITE SUPERIOR®	6G/GT/GTL825	1
95.86.813-NAN	AlphaRail wiring rail	WHITE SUPERIOR®	8G/GTL825	1
95.86.613-NAN	AlphaRail wiring rail	WHITE SUPERIOR®	12GTLA825	2
95.86.616-NAN	AlphaRail wiring rail	WHITE SUPERIOR®	12SGT	2
95.86.816-NAN	AlphaRail wiring rail	WHITE SUPERIOR®	16GT/GTLB825	2
95.86.816-NAN	AlphaRail wiring rail	WHITE SUPERIOR®	16SGT	2
95.87.531-NAN-08	AlphaRail wiring rail	WORTHINGTON®	UTC-10	2

<sup>1)</sup> NOTE: Applications may vary due to different variants or attachments, which could affect the installation of mentioned wiring rails. Consult factory for details and final confirmation.

# Ignition Wiring Rails & Hardware



## 2 Bracket Configuration

P/N <sup>1)</sup>	Figure	Description
75.10.303	2A	Bracket, 40x40 mm (Standard)
75.10.097	2B	Flat bar, 180° (Standard)
75.10.120	2C	Flat bar, 150°
75.10.280	2D	Flat bar, 90°

<sup>1)</sup> For packs of ten please add suffix "-10" to part number.

## 3 Primary Lead Kits for Ignition Coils – Unshielded <sup>1)</sup>

P/N	Figure	Description	For use with Ignition Coil P/N
06.99.200-1	3A	Primary lead kit incl. fastening material for ignition coil	06.50.003, 06.50.053, 06.50.054, 06.50.055, 06.50.060, 06.50.065
06.99.200-2	3B	Primary lead kit incl. fastening material for ignition coil	06.50.100, 06.50.102, 06.50.104, 06.50.105, 06.50.112, 06.50.113, 06.50.300, 06.50.301
06.99.200-3	3C	Primary lead kit incl. fastening material for ignition coil	06.50.103

<sup>1)</sup> Primary lead kits have to be ordered separately in required quantity.

## 3 Primary Lead Kits for Ignition Coils – Shielded <sup>1)</sup>

P/N	Figure	Description	For use with Ignition Coil P/N
95.99.200-1	3D	Primary lead kit incl. fastening material	95.08.003, 95.08.070
95.99.200-2	3E	Primary lead kit incl. fastening material	95.09.005, 95.09.054, 95.09.055, 95.09.070, 95.09.074, 95.09.075
95.99.200-2-X	3E	Primary lead kit incl. fastening material	95.09.053, 95.09.073

<sup>1)</sup> Primary lead kits have to be ordered separately in required quantity. See page 66 for primary leads for use with flange or integral ignition coils.

## 4 Harnesses to connect Wiring Rail and Junction Box <sup>1)</sup>

P/N	Figure	Description	Connector	Length
95.40.114-L	4A	Harness	MIL, 14 pole, socket, 180°	L= 5/15/25/50 ft.
95.40.314-L	4B	Harness	MIL, 14 pole, socket, 90°	L= 5/15/25/50 ft.

<sup>1)</sup> For CSA applications flex conduit has to be ordered separately or supplied by customer.



# Ignition Wiring Rails & Hardware

## 5 Harnesses to connect Ignition Controller and Junction Box – Specification Table

P/N 95.4 **A** . **B** **C** **D** - **E**

A	Harness
0	Standard harness (with adaptor for 1/2 in. or 3/4 in. flex conduit)

B	Connector Arrangement
1	socket 180°
2	pin 180°
3	socket 90°
4	pin 90°

CD	Number of Sockets/Pins in Connector
05	5 pole, with adaptor for 1/2 in. flex conduit
07	7 pole, with adaptor for 1/2 in. flex conduit
10	10 pole, with adaptor for 1/2 in. flex conduit
14	14 pole, with adaptor for 1/2 in. flex conduit
17	17 pole, with adaptor for 3/4 in. flex conduit
19	19 pole, with adaptor for 3/4 in. flex conduit
35	35 pole, with adaptor for 3/4 in. flex conduit

E	Length of Harness
5	5 ft.
15	15 ft.
25	25 ft.
50	50 ft.



Specification Charts:  
[www.motortech.de](http://www.motortech.de)

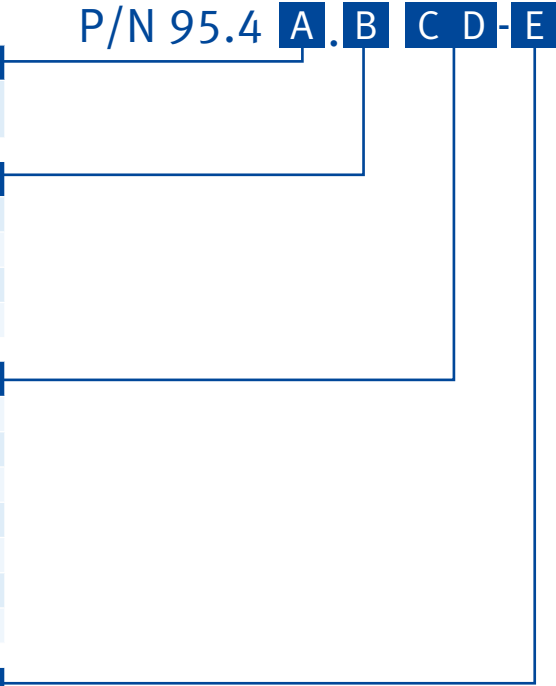

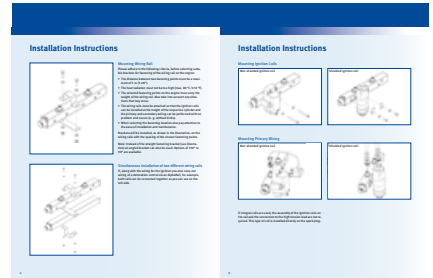
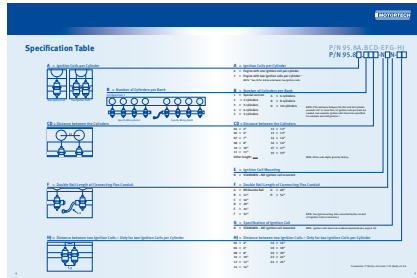
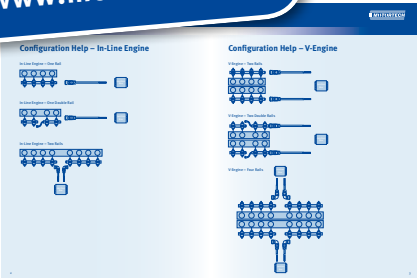
## 6 Accessories

P/N	Figure	Description
06.05.075	6A	Junction box
15.07.112	6B	Flex conduit, 1/2 in., black <sup>1)</sup>
15.07.221	6C	Fitting, 1/2 in., junction box to flex conduit
15.07.134	6B	Flex conduit, 3/4 in., black <sup>1)</sup>
15.07.231	6C	Fitting, 3/4 in., junction box to flex conduit

<sup>1)</sup> Flex conduit needs to be ordered in m/ft. in required quantity.



6A



6B



6C

# Ignition Wiring Rails & Hardware

SHIELDED

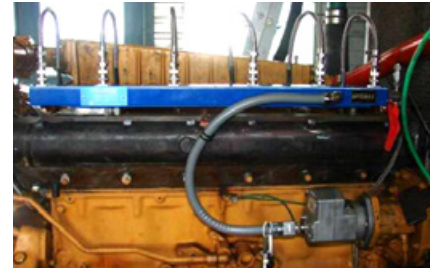

## Ignition Wiring Rail Upgrade Kits

Wiring Rail Kits for CATERPILLAR® G3300 and G3400 Series Gas Engines – **Shielded Applications with Magneto**



P/N	Description	Equivalent to
95.75.025-1-B	<b>Ignition wiring rail kit without ignition control unit for CATERPILLAR® G3304</b> <ul style="list-style-type: none"> <li>• Incl. harness to ALTRONIC® magneto</li> <li>• Mounting bracket welded to the rail</li> <li>• G-lead connector</li> <li>• <b>New Flex Style</b> shielded primary leads to fit 3 pole integral ignition coils <sup>1)</sup></li> <li>• Timing adaptor</li> </ul>	251-2052
95.75.025-1	<b>Ignition wiring rail kit without ignition control unit for CATERPILLAR® G3304</b> <ul style="list-style-type: none"> <li>• Incl. harness to ALTRONIC® magneto</li> <li>• Mounting bracket welded to the rail</li> <li>• G-lead connector</li> <li>• <b>Conventional Style</b> shielded primary leads to fit 3 pole integral ignition coils <sup>1)</sup></li> <li>• Timing adaptor</li> </ul>	251-2052
95.75.024-1-B	<b>Ignition wiring rail kit without ignition control unit for CATERPILLAR® G3306</b> <ul style="list-style-type: none"> <li>• Incl. harness to ALTRONIC® magneto</li> <li>• Mounting bracket welded to the rail</li> <li>• G-lead connector</li> <li>• <b>New Flex Style</b> shielded primary leads to fit 3 pole integral ignition coils <sup>1)</sup></li> <li>• Timing adaptor</li> </ul>	251-2053
95.75.024-1	<b>Ignition wiring rail kit without ignition control unit for CATERPILLAR® G3306</b> <ul style="list-style-type: none"> <li>• Incl. harness to ALTRONIC® magneto</li> <li>• Mounting bracket welded to the rail</li> <li>• G-lead connector</li> <li>• <b>Conventional Style</b> shielded primary leads to fit 3 pole integral ignition coils <sup>1)</sup></li> <li>• Timing adaptor</li> </ul>	251-2053
95.75.067-1-B	<b>Ignition wiring rail kit without ignition control unit for CATERPILLAR® G3406</b> <ul style="list-style-type: none"> <li>• Incl. harness to ALTRONIC® ignition control unit</li> <li>• Mounting bracket welded to the rail</li> <li>• G-lead connector</li> <li>• <b>New Flex Style</b> shielded primary leads to fit 3 pole integral ignition coils <sup>1)</sup></li> <li>• Timing adaptor</li> </ul>	291-5862 (wiring rail) 290-7079 (harness)
95.75.067-1	<b>Ignition wiring rail kit without ignition control unit for CATERPILLAR® G3406</b> <ul style="list-style-type: none"> <li>• Incl. harness to ALTRONIC® ignition control unit</li> <li>• Mounting bracket welded to the rail</li> <li>• G-lead connector</li> <li>• <b>Conventional Style</b> shielded primary leads to fit 3 pole integral ignition coils <sup>1)</sup></li> <li>• Timing adaptor</li> </ul>	291-5862 (wiring rail) 290-7079 (harness)

<sup>1)</sup> Integral ignition coils need to be ordered separately. See page 46.

### Options available on included Primary Leads

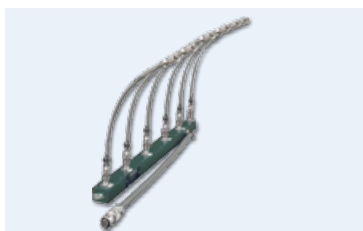

Ignition Wiring Rail

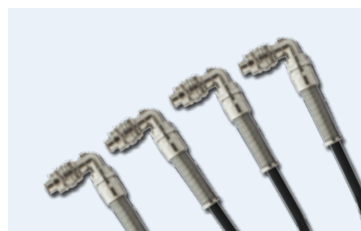

**New Flex Style** Primary Leads

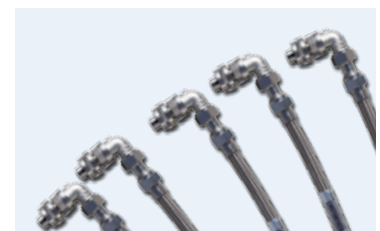

**Conventional Style** Primary Leads

# Ignition Wiring Rails & Hardware



UNSHIELDED

Ignition Upgrade Kits for CATERPILLAR® G3300 and G3400 Series Gas Engines to replace Magneto Ignition Systems  
**Unshielded Applications**

P/N	Supersedes	Description	Equivalent to
75.00.536	75.00.338	<b>Ignition upgrade kit for CATERPILLAR® G3304</b> <ul style="list-style-type: none"> <li>• Incl. MIC3+ ignition controller</li> <li>• Input and output harnesses</li> <li>• AlphaRail wiring rail with high energy ignition coils and brackets</li> <li>• Spark plug leads</li> <li>• Mechanical trigger kit with disc (4+1), adapter ring, gaskets and inductive pickup</li> <li>• Magneto drive cover kit</li> </ul>	
75.00.537	75.00.337	<b>Ignition upgrade kit for CATERPILLAR® G3306</b> <ul style="list-style-type: none"> <li>• Incl. MIC3+ ignition controller</li> <li>• Input and output harnesses</li> <li>• AlphaRail wiring rail with high energy ignition coils and brackets</li> <li>• Spark plug leads</li> <li>• Mechanical trigger kit with disc (6+1), adapter ring, gaskets and inductive pickup</li> <li>• Magneto drive cover kit</li> </ul>	
75.00.538	75.00.336	<b>Ignition upgrade kit for CATERPILLAR® G3406</b> <ul style="list-style-type: none"> <li>• Incl. MIC3+ ignition controller</li> <li>• Input and output harnesses</li> <li>• AlphaRail wiring rail with high energy ignition coils and brackets</li> <li>• PolyMot™ spark plug leads</li> <li>• Mechanical trigger kit with disc (6+1), adapter ring, gaskets and inductive pickup</li> <li>• Magneto drive cover kit</li> </ul>	
75.00.539		<b>Ignition upgrade kit for CATERPILLAR® G3408</b> <ul style="list-style-type: none"> <li>• Incl. MIC3+ ignition controller</li> <li>• Input and output harnesses</li> <li>• AlphaRail wiring rails with high energy ignition coils and brackets</li> <li>• PolyMot™ spark plug leads</li> <li>• TriDev trigger device and inductive pickup</li> </ul>	
75.00.540		<b>Ignition upgrade kit for CATERPILLAR® G3412</b> <ul style="list-style-type: none"> <li>• Incl. MIC3+ ignition controller</li> <li>• Input and output harnesses</li> <li>• AlphaRail wiring rails with high energy ignition coils and brackets</li> <li>• PolyMot™ spark plug leads</li> <li>• TriDev trigger device and inductive pickup</li> </ul>	

Ignition Systems

Kit for In-line Engines  
 CATERPILLAR® G3304/G3306/G3406

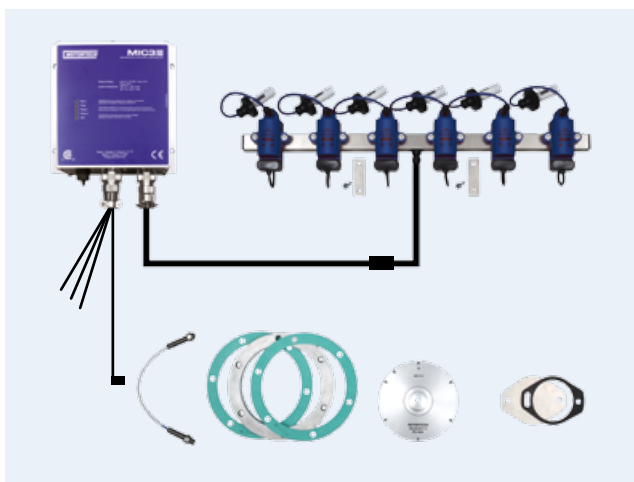

Kit for V-Engines  
 CATERPILLAR® G3408/G3412

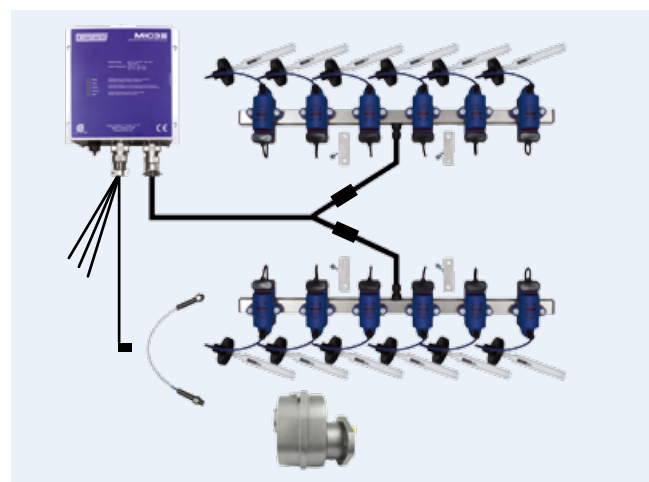

# Ignition Wiring Rails & Hardware

SHIELDED



## Wiring Rail Kits for CATERPILLAR® G3600 Series Gas Engines



P/N	Description	Equivalent to
95.75.108-B	<b>Wiring rail kit, ignition/detonation control for CATERPILLAR® G3606</b> <ul style="list-style-type: none"> <li>AlphaRail wiring rail assembly</li> <li>Connecting harness, main junction box to wiring rail</li> <li><b>New Flex Style</b> shielded primary leads for AlphaRail</li> </ul>	213-6308
95.75.108	<b>Wiring rail kit, ignition/detonation control for CATERPILLAR® G3606</b> <ul style="list-style-type: none"> <li>AlphaRail wiring rail assembly</li> <li>Connecting harness, main junction box to wiring rail</li> <li><b>Conventional Style</b> shielded primary leads for AlphaRail</li> </ul>	213-6308
95.75.103-B	<b>Wiring rail kit, ignition/detonation control for CATERPILLAR® G3608</b> <ul style="list-style-type: none"> <li>AlphaRail wiring rail assembly</li> <li>Connecting harness, main junction box to wiring rail</li> <li><b>New Flex Style</b> shielded primary leads for AlphaRail</li> </ul>	219-9946
95.75.103	<b>Wiring rail kit, ignition/detonation control for CATERPILLAR® G3608</b> <ul style="list-style-type: none"> <li>AlphaRail wiring rail assembly</li> <li>Connecting harness, main junction box to wiring rail</li> <li><b>Conventional Style</b> shielded primary leads for AlphaRail</li> </ul>	219-9946
95.75.106-B	<b>Wiring rail kit, ignition/detonation control for CATERPILLAR® G3612</b> <ul style="list-style-type: none"> <li>AlphaRail wiring rail assembly, right and left bank</li> <li>Connecting harnesses, main junction box to wiring rails</li> <li><b>New Flex Style</b> shielded primary leads for AlphaRail</li> </ul>	191-5007 (right) 191-5008 (left)
95.75.106	<b>Wiring rail kit, ignition/detonation control for CATERPILLAR® G3612</b> <ul style="list-style-type: none"> <li>AlphaRail wiring rail assembly, right and left bank</li> <li>Connecting harnesses, main junction box to wiring rails</li> <li><b>Conventional Style</b> shielded primary leads for AlphaRail</li> </ul>	191-5007 (right) 191-5008 (left)
95.75.107-B	<b>Wiring rail kit, ignition/detonation control for CATERPILLAR® G3616</b> <ul style="list-style-type: none"> <li>AlphaRail wiring rail assembly, right and left bank</li> <li>Connecting harnesses, main junction box to wiring rails</li> <li><b>New Flex Style</b> shielded primary leads for AlphaRail</li> </ul>	198-2938 (right) 198-2941 (left)
95.75.107	<b>Wiring rail kit, ignition/detonation control for CATERPILLAR® G3616</b> <ul style="list-style-type: none"> <li>AlphaRail wiring rail assembly, right and left bank</li> <li>Connecting harnesses, main junction box to wiring rails</li> <li><b>Conventional Style</b> shielded primary leads for AlphaRail</li> </ul>	198-2938 (right) 198-2941 (left)

### Options available on included Primary Leads



AlphaRail Wiring Rail Assembly



Connecting Harness



**New Flex Style** Primary Leads

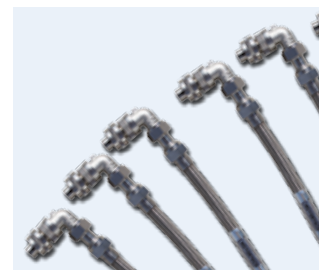

**Conventional Style** Primary Leads



# Ignition Wiring Rails & Hardware



## Wiring Rail Kits for WAUKESHA® VGF Series Gas Engines – Shielded Applications with CEC Ignition Controller



P/N	Description	Equivalent to
95.75.339	<b>Ignition wiring rail upgrade kit for WAUKESHA® VGF F18</b> For use with existing WAUKESHA® CEC ignition controller <ul style="list-style-type: none"> <li>• AlphaRail wiring rail and mounting brackets</li> <li>• Connecting harness, ignition controller to wiring rail</li> <li>• <b>New Flex Style</b> shielded primary leads for AlphaRail</li> </ul>	
95.75.340	<b>Ignition wiring rail upgrade kit for WAUKESHA® VGF H24</b> For use with existing WAUKESHA® CEC ignition controller <ul style="list-style-type: none"> <li>• AlphaRail wiring rail and mounting brackets</li> <li>• Connecting harness, ignition controller to wiring rail</li> <li>• <b>New Flex Style</b> shielded primary leads for AlphaRail</li> </ul>	

Ignition Systems



## Wiring Rail Kits for 12 Cylinder WAUKESHA® VHP ESM Series Gas Engines



P/N	Description	Equivalent to
95.75.048-B	<b>Ignition wiring rail kit for 12 Cylinder WAUKESHA® VHP ESM Series Gas Engines</b> <ul style="list-style-type: none"> <li>• AlphaRail wiring rails and mounting brackets</li> <li>• Connecting harness assembly, ESM to wiring rails</li> <li>• <b>New Flex Style</b> shielded primary leads for AlphaRail</li> </ul>	740283
95.75.048	<b>Ignition wiring rail kit for 12 Cylinder WAUKESHA® VHP ESM Series Gas Engines</b> <ul style="list-style-type: none"> <li>• AlphaRail wiring rails and mounting brackets</li> <li>• Connecting harness assembly, ESM to wiring rails</li> <li>• <b>Conventional Style</b> shielded primary leads for AlphaRail</li> </ul>	740283

### Options available on included Primary Leads



AlphaRail Wiring Rail



Connecting Harness Assembly



**New Flex Style** Primary Leads

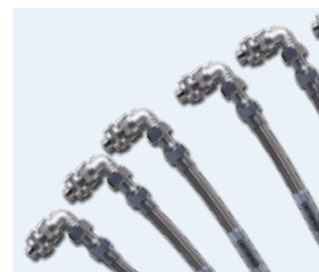



**Conventional Style** Primary Leads

# Ignition Wiring Rails & Hardware



## Upgrade Kits for WAUKESHA® VHP G/GU/GSI 12 Cylinder Gas Engines – Ignition and Detonation Control

P/N	Description
95.75.120-12 	<p><b>Shielded ignition control upgrade kit for WAUKESHA® VHP G/GU/GSI 12 cylinder engines</b></p> <ul style="list-style-type: none"> <li>• MIC4 series ignition controller</li> <li>• 3 pickup arrangement (1 Hall effect, 2 magnetic) incl. shielded pickup leads, trigger disc and hub</li> <li>• Output wiring and junction box with fittings to connect ignition controller and wiring rails</li> <li>• AlphaRail wiring rails with hardware kit</li> <li>• High energy integral ignition coils</li> <li>• <b>New Flex Style</b> primary leads for connection of wiring rails and integral ignition coils</li> </ul>
77.75.120-12	<p><b>Unshielded ignition control upgrade kit for WAUKESHA® VHP G/GU/GSI 12 cylinder engines</b></p> <ul style="list-style-type: none"> <li>• MIC4 series ignition controller</li> <li>• 3 pickup arrangement (1 Hall effect, 2 magnetic) incl. shielded pickup leads, trigger disc and hub</li> <li>• Output wiring and junction box with fittings to connect ignition controller and wiring rails</li> <li>• AlphaRail wiring rails with hardware kit</li> <li>• High energy ignition coils</li> <li>• Primary lead and mounting kits for connection of wiring rails and ignition coils</li> <li>• PolyMot™ spark plug leads</li> </ul>
95.75.121-12 	<p><b>Shielded ignition control upgrade kit for WAUKESHA® VHP G/GU/GSI 12 cylinder engines</b> <b>For use with existing WAUKESHA® CEC ignition controller</b></p> <ul style="list-style-type: none"> <li>• Output wiring and junction box with fittings to connect CEC ignition controller and wiring rails</li> <li>• AlphaRail wiring rails with hardware kit</li> <li>• Integral ignition coils to work with CEC Spark Reference System</li> <li>• <b>New Flex Style</b> primary leads for connection of wiring rails and integral ignition coils</li> </ul>
77.75.121-12	<p><b>Unshielded ignition control upgrade kit for WAUKESHA® VHP G/GU/GSI 12 cylinder engines</b> <b>For use with existing WAUKESHA® CEC ignition controller</b></p> <ul style="list-style-type: none"> <li>• Output wiring and junction box with fittings to connect CEC ignition controller and wiring rails</li> <li>• AlphaRail wiring rails with hardware kit</li> <li>• Ignition coils to work with CEC Spark Reference System</li> <li>• Primary lead and mounting kits for connection of wiring rails and ignition coils</li> <li>• PolyMot™ spark plug leads</li> </ul>
43.00.421-12 <sup>1)</sup>	<p><b>Detonation control upgrade kit for WAUKESHA® VHP G/GU/GSI/GL 12 cylinder engines</b></p> <ul style="list-style-type: none"> <li>• DetCon20 detonation controller with 20 inputs</li> <li>• Harnesses to connect detonation controller and wiring rails</li> <li>• AlphaRail wiring rails with hardware kit</li> <li>• Leads for connection of wiring rails and detonation sensors</li> <li>• Detonation sensors to monitor each cylinder individually</li> <li>• Prepared cylinder head cap screws for each detonation sensor available on request</li> </ul>

<sup>1)</sup> For use in hazardous and non-hazardous environments.

## Ignition Kits for Unshielded Applications

### Ignition Kits for MAN® E0834 Series Gas Engines

P/N	Engine Model	Ignition Controller	Wiring Rail Type	Ignition Coil P/N	PolyMot™ Spark Plug Lead		Pickup P/N	Mounting Kit for Wiring Rail P/N <sup>2)</sup>
					P/N	Fits Spark Plug <sup>1)</sup>		
75.00.651	E0834 E302/312/LE302	MIC3+ series	LiteRail	06.50.300	06.85.839H-16	GK3-5	66.60.003-60	75.41.006
75.00.581 <sup>3)</sup>	E0834 E302/312/LE302	MIC3+ series	LiteRail	06.50.300	06.85.1037-16	B4321	66.60.003-60	75.41.006
75.00.501	E0834 E302/312/LE302	MIC4 series	LiteRail	06.50.104	06.85.839H-16	GK3-5	66.60.003-60	75.41.006
75.00.601 <sup>3)</sup>	E0834 E302/312/LE302	MIC4 series	LiteRail	06.50.104	06.85.1037-16	B4321	66.60.003-60	75.41.006

### Ignition Kits for MAN® E0836 Series Gas Engines

P/N	Engine Model	Ignition Controller	Wiring Rail Type	Ignition Coil P/N	PolyMot™ Spark Plug Lead		Pickup P/N	Mounting Kit for Wiring Rail P/N <sup>2)</sup>
					P/N	Fits Spark Plug <sup>1)</sup>		
75.00.652	E0836 E302/312	MIC3+ series	LiteRail	06.50.300	06.85.839H-16	GK3-5	66.60.003-60	75.41.011
75.00.582 <sup>3)</sup>	E0836 E302/312	MIC3+ series	LiteRail	06.50.300	06.85.1037-16	B4321	66.60.003-60	75.41.011
75.00.502	E0836 E302/312	MIC4 series	LiteRail	06.50.104	06.85.839H-16	GK3-5	66.60.003-60	75.41.011
75.00.602 <sup>3)</sup>	E0836 E302/312	MIC4 series	LiteRail	06.50.104	06.85.1037-16	B4321	66.60.003-60	75.41.011
75.00.653	E0836 LE202	MIC3+ series	LiteRail	06.50.300	06.85.836H-16	GE3-5	66.60.003-60	75.41.011
75.00.583 <sup>3)</sup>	E0836 LE202	MIC3+ series	LiteRail	06.50.300	06.85.1031-16	B4321	66.60.003-60	75.41.011
75.00.503	E0836 LE202	MIC4 series	LiteRail	06.50.104	06.85.836H-16	GE3-5	66.60.003-60	75.41.011
75.00.603 <sup>3)</sup>	E0836 LE202	MIC4 series	LiteRail	06.50.104	06.85.1031-16	B4321	66.60.003-60	75.41.011

### Ignition Kits for MAN® E2876 Series Gas Engines

P/N	Engine Model	Ignition Controller	Wiring Rail Type	Ignition Coil P/N	PolyMot™ Spark Plug Lead		Pickup P/N	Mounting Kit for Wiring Rail P/N <sup>2)</sup>
					P/N	Fits Spark Plug <sup>1)</sup>		
75.00.654	E2876 E302/312/TE302	MIC3+ series	LiteRail	06.50.300	06.85.836H-16	GE3-5	66.60.003-60	75.41.005
75.00.584 <sup>3)</sup>	E2876 E302/312/TE302	MIC3+ series	LiteRail	06.50.300	06.85.1031-16	B4321	66.60.003-60	75.41.005
75.00.504	E2876 E302/312/TE302	MIC4 series	LiteRail	06.50.104	06.85.836H-16	GE3-5	66.60.003-60	75.41.005
75.00.604 <sup>3)</sup>	E2876 E302/312/TE302	MIC4 series	LiteRail	06.50.104	06.85.1031-16	B4321	66.60.003-60	75.41.005
75.00.656	E2876 LE202/212/302	MIC3+ series	LiteRail	06.50.300	06.85.836H-16	GE3-5	66.60.003-60	75.41.014, alternative 75.41.025
75.00.586 <sup>3)</sup>	E2876 LE202/212/302	MIC3+ series	LiteRail	06.50.300	06.85.1031-16	B4321	66.60.003-60	75.41.014, alternative 75.41.025
75.00.506	E2876 LE202/212/302	MIC4 series	LiteRail	06.50.104	06.85.836H-16	GE3-5	66.60.003-60	75.41.014, alternative 75.41.025
75.00.606 <sup>3)</sup>	E2876 LE202/212/302	MIC4 series	LiteRail	06.50.104	06.85.1031-16	B4321	66.60.003-60	75.41.014, alternative 75.41.025

<sup>1)</sup> Mentioned spark plugs for comparison purposes only and not included in scope of supply.

<sup>2)</sup> Mounting kits for wiring rails are not included in scope of supply and need to be ordered separately.

<sup>3)</sup> Ignition kit includes magnetic spark plug socket to fit MHP spark plug B4321 with long insulator.

## Ignition Wiring Rails & Hardware



### Ignition Kits for MAN® E2676 Series Gas Engines

P/N	Engine Model	Ignition Controller	Wiring Rail Type	Ignition Coil P/N	PolyMot™ Spark Plug Lead		Pickup P/N	Mounting Kit for Wiring Rail P/N <sup>2)</sup>
					P/N	Fits Spark Plug <sup>1)</sup>		
75.00.655	E2676 LE202/212	MIC3+ series	LiteRail	06.50.300	06.85.929-20	GK3-5	66.60.003-60	75.41.003
75.00.585 <sup>3)</sup>	E2676 LE202/212	MIC3+ series	LiteRail	06.50.300	06.85.1038-20	B4321	66.60.003-60	75.41.003
75.00.505	E2676 LE202/212	MIC4 series	LiteRail	06.50.104	06.85.929-20	GK3-5	66.60.003-60	75.41.003
75.00.605 <sup>3)</sup>	E2676 LE202/212	MIC4 series	LiteRail	06.50.104	06.85.1038-20	B4321	66.60.003-60	75.41.003

### Ignition Kits for MAN® E2848 Series Gas Engines

P/N	Engine Model	Ignition Controller	Wiring Rail Type	Ignition Coil P/N	PolyMot™ Spark Plug Lead		Pickup P/N	Mounting Kit for Wiring Rail P/N <sup>2)</sup>
					P/N	Fits Spark Plug <sup>1)</sup>		
75.00.657	E2848 LE322	MIC3+ series	LiteRail	06.50.300	06.85.836H-16	GE3-5	66.60.003-100	75.41.002, alternative 75.41.026
75.00.587 <sup>3)</sup>	E2848 LE322	MIC3+ series	LiteRail	06.50.300	06.85.1031-16	B4321	66.60.003-100	75.41.002, alternative 75.41.026
75.00.507	E2848 LE322	MIC4 series	LiteRail	06.50.104	06.85.836H-16	GE3-5	66.60.003-100	75.41.002, alternative 75.41.026
75.00.607 <sup>3)</sup>	E2848 LE322	MIC4 series	LiteRail	06.50.104	06.85.1031-16	B4321	66.60.003-100	75.41.002, alternative 75.41.026

### Ignition Kits for MAN® E2842 Series Gas Engines

P/N	Engine Model	Ignition Controller	Wiring Rail Type	Ignition Coil P/N	PolyMot™ Spark Plug Lead		Pickup P/N	Mounting Kit for Wiring Rail P/N <sup>2)</sup>
					P/N	Fits Spark Plug <sup>1)</sup>		
75.00.658	E2842 E/LE312	MIC3+ series	LiteRail	06.50.300	06.85.836H-16	GE3-5	66.60.003-100	75.41.013
75.00.588 <sup>3)</sup>	E2842 E/LE312	MIC3+ series	LiteRail	06.50.300	06.85.1031-16	B4321	66.60.003-100	75.41.013
75.00.508	E2842 E/LE312	MIC4 series	LiteRail	06.50.104	06.85.836H-16	GE3-5	66.60.003-100	75.41.013
75.00.608 <sup>3)</sup>	E2842 E/LE312	MIC4 series	LiteRail	06.50.104	06.85.1031-16	B4321	66.60.003-100	75.41.013
75.00.659	E2842 LE202/322/332	MIC3+ series	LiteRail	06.50.300	06.85.836H-16	GE3-5	66.60.003-100	75.41.001, alternative 75.41.027
75.00.589 <sup>3)</sup>	E2842 LE202/322/332	MIC3+ series	LiteRail	06.50.300	06.85.1031-16	B4321	66.60.003-100	75.41.001, alternative 75.41.027
75.00.509	E2842 LE202/322/332	MIC4 series	LiteRail	06.50.104	06.85.836H-16	GE3-5	66.60.003-100	75.41.001, alternative 75.41.027
75.00.609 <sup>3)</sup>	E2842 LE202/322/332	MIC4 series	LiteRail	06.50.104	06.85.1031-16	B4321	66.60.003-100	75.41.001, alternative 75.41.027

<sup>1)</sup> Mentioned spark plugs for comparison purposes only and not included in scope of supply.

<sup>2)</sup> Mounting kits for wiring rails are not included in scope of supply and need to be ordered separately.

<sup>3)</sup> Ignition kit includes magnetic spark plug socket to fit MHP spark plug B4321 with long insulator.

# Ignition Wiring Rails & Hardware



## Ignition Kits for MAN® E3268 Series Gas Engines

P/N	Engine Model	Ignition Controller	Wiring Rail Type	Ignition Coil P/N	PolyMot™ Spark Plug Lead		Pickup P/N	Mounting Kit for Wiring Rail P/N <sup>2)</sup>
					P/N	Fits Spark Plug <sup>1)</sup>		
75.00.661	E3268 LE212/222	MIC3+ series	LiteRail	06.50.300	06.85.959-18	GE3-5	66.60.003-100	75.41.023
75.00.591 <sup>3)</sup>	E3268 LE212/222	MIC3+ series	LiteRail	06.50.300	06.85.1023-18	B4321	66.60.003-100	75.41.023
75.00.595	E3268 LE212/222	MIC3+ series	LiteRail	06.50.300	06.85.1042-18	GL3-5, B8324	66.60.003-100	75.41.023
75.00.511	E3268 LE212/222	MIC4 series	LiteRail	06.50.104	06.85.959-18	GE3-5	66.60.003-100	75.41.023
75.00.611 <sup>3)</sup>	E3268 LE212/222	MIC4 series	LiteRail	06.50.104	06.85.1023-18	B4321	66.60.003-100	75.41.023
75.00.596	E3268 LE212/222	MIC4 series	LiteRail	06.50.112	06.85.1042-18	GL3-5, B8324	66.60.003-100	75.41.023

## Ignition Kits for MAN® E3262 Series Gas Engines

P/N	Engine Model	Ignition Controller	Wiring Rail Type	Ignition Coil P/N	PolyMot™ Spark Plug Lead		Pickup P/N	Mounting Kit for Wiring Rail P/N <sup>2)</sup>
					P/N	Fits Spark Plug <sup>1)</sup>		
75.00.660	E3262 LE202/212	MIC3+ series	LiteRail	06.50.300	06.85.959-18	GE3-5	66.60.003-100	75.41.023
75.00.590 <sup>3)</sup>	E3262 LE202/212	MIC3+ series	LiteRail	06.50.300	06.85.1023-18	B4321	66.60.003-100	75.41.023
75.00.597	E3262 LE202/212	MIC3+ series	LiteRail	06.50.300	06.85.1042-18	GL3-5, B8324	66.60.003-100	75.41.023
75.00.510	E3262 LE202/212	MIC4 series	LiteRail	06.50.104	06.85.959-18	GE3-5	66.60.003-100	75.41.023
75.00.610 <sup>3)</sup>	E3262 LE202/212	MIC4 series	LiteRail	06.50.104	06.85.1023-18	B4321	66.60.003-100	75.41.023
75.00.598	E3262 LE202/212	MIC4 series	LiteRail	06.50.112	06.85.1042-18	GL3-5, B8324	66.60.003-100	75.41.023

<sup>1)</sup> Mentioned spark plugs for comparison purposes only and not included in scope of supply.

<sup>2)</sup> Mounting kits for wiring rails are not included in scope of supply and need to be ordered separately.

<sup>3)</sup> Ignition kit includes magnetic spark plug socket to fit MHP spark plug B4321 with long insulator.



## Ignition Kits for LIEBHERR® Gas Engines

P/N	Engine Model	Ignition Controller	Wiring Rail Type	Ignition Coil P/N	Spark Plug <sup>1)</sup>	Pickup <sup>2)</sup>	Mounting Kit for Wiring Rail
75.00.433	G944	MIC4 series	AlphaRail	06.50.104	not included	not included	75.41.010
75.00.434	G946	MIC4 series	AlphaRail	06.50.104	not included	not included	75.41.008
75.00.435	G9508	MIC4 series	AlphaRail	06.50.104	not included	not included	75.41.022
75.00.436	G9512	MIC4 series	AlphaRail	06.50.104	not included	not included	75.41.021

<sup>1)</sup> MOTORTECH XTL Plug P/N B432BEX9-A107 has to be ordered separately in required quantity.

<sup>2)</sup> Scope of supply only includes wiring for LIEBHERR® pickup.







# Ignition Tools & Test Equipment

## SparkView MOTORTECH HIGH VOLTAGE INDICATOR

The SparkView is a handheld device developed by MOTORTECH that can monitor the high voltage required by the spark plug while the engine is running. With a measuring clamp or cable and the display for up to 40 kV, it is easy to determine the condition of the spark plugs and the time at which they need to be replaced. This guarantees a constant performance of the engine and a maximum utilization of the spark plugs.

Quick and comfortable monitoring on a running engine makes it possible to detect

- Wear of spark plugs
- Failure of the ignition system (damaged ignition coil, spark plug lead or ignition controller)
- Faulty compression of a cylinder



### SparkView High Voltage Indicator

P/N	Figure	Description
06.90.099-100	<b>1</b>	SparkView high voltage indicator, incl. SparkScan1 high voltage clamp P/N 06.90.100, for use with spark plug leads
06.90.099-105	<b>2</b>	SparkView high voltage indicator, incl. BNC cable P/N 06.90.105, for use with flange ignition coils or externally mounted ignition coils with diagnostic interface



## SparkScan1 MOTORTECH HIGH VOLTAGE CLAMP

SparkScan1 is designed for operators who want to monitor their high voltage traces in a simple way. The inductive high voltage clamp is connected to a Scope Meter. When attaching the clamp to a conventional spark plug wire (7mm), the probe measures the high voltage pulse and via scope screen the operator can analyse the trace. Measuring high voltage peak (kV) and spark duration ( $\mu\text{sec}$ ) of all cylinders of an engine in a routine manner, will allow preventive maintenance of the equipment.



Ignition  
Systems

### SparkScan1 High Voltage Clamp

P/N	Description	Length
06.90.100	SparkScan1 high voltage clamp	2.0 m/7.0 ft.

### Digital Scope Meter

The digital scope meter is a compact 20 MHz or 40MHz two channel scope. Ideal for troubleshooting of industrial machinery, instrumentation, control and power systems. The scope meter has unique features like connect-and-view and trendplot that simplify taking measurements and reduce troubleshooting time when working in the field or in industrial environments.



### Digital Scope Meter

P/N	Description
06.98.005-110	Digital scope meter, 110 V
06.98.005-220	Digital scope meter, 220 V

### BNC Cable for use with SparkView or Digital Scope Meter

P/N	Description	Length
06.90.105	BNC cable	2.0 m/7.0 ft.



# Ignition Tools & Test Equipment



This test equipment is designed to offer service companies a professional tool to test all different kinds of ignition coils that were sold by engine manufacturers or aftermarket companies. A built in CD ignition, high voltage clamp and a spark gap allow realistic testing.



## Ignition Coil Tester

P/N	Description
06.98.054	Ignition coil tester, incl. standard adaptor kits for popular ignition coils

## Adaptor Kits – Standard – including Teflon Ignition Coil Adaptors and Connecting Leads <sup>1)</sup>

P/N	Description	Connections of included Lead	
		Ignition Coil	Ignition Coil Tester
06.98.054-1	Adaptor kit for CATERPILLAR® ignition coils, G3400 & G3500	DEUTSCH® connector	XLR connector
06.98.054-2	Adaptor kit for ALTRONIC® Style ignition coils	2 pole	XLR connector
06.98.054-3	Adaptor kit for MOTORTECH Style ignition coils	2 pole	XLR connector
06.98.054-4	Adaptor kit for flange ignition coils	MIL, 3 pole, socket, 180°	XLR connector
06.98.054-5	Adaptor kit for integral ignition coils, outer thread	MIL, 2/3 pole, socket, 180°	XLR connector
06.98.054-6	Adaptor kit for integral ignition coils, inner thread	MIL, 2/3 pole, socket, 180°	XLR connector
06.98.054-7	Adaptor kit for externally mounted ignition coils	MIL, 2/3 pole, socket, 180°	XLR connector

<sup>1)</sup> All adaptor kits included in ignition coil tester.

## Adaptor Kits – Special – including Connecting Leads

P/N	Description	Connections of included Lead	
		Ignition Coil	Ignition Coil Tester
06.70.192-5	Adaptor kit for CUMMINS® ignition coil P/N 3964547	4 pole, 180°	XLR connector
06.70.192-6	Adaptor kit for GE JENBACHER® ignition coil P/N 369083	4 pole, 180°	XLR connector



## MOTORTECH IGNITION PICKUP SIMULATOR

Anyone trying to troubleshoot electronic ignition systems has come to the conclusion that there are so many different things that can create problems.

The ignition pickup simulator allows the operator to simulate all pickup signals that are supposed to be generated by the different pickups installed on flywheel and camshaft. This way the ignition can actually be triggered with the appropriate amount of trigger events while the engine is not cranking. The IPS can be programmed for single and multiple pickup signal frequency.

A variety of adaptor harnesses is available to allow use of the IPS with different ignition controller brands and models.



Ignition Systems

### IPS Ignition Pickup Simulator

P/N	Description
07.98.047	IPS Ignition Pickup Simulator

### Adaptor Harnesses for IPS Ignition Pickup Simulator <sup>1)</sup>

P/N	IPS Adaptor Harness for use with
07.70.001	WOODWARD® IC9xx series
07.70.002-1	MOTORTECH MIC500 series (P/N 06.00.508), WOODWARD® IC100 series with inductive pickup
07.70.002-2	MOTORTECH MIC500 series (P/N 06.00.508), WOODWARD® IC100 series with Hall effect pickup
07.70.002-3	MOTORTECH MIC500 series (P/N 06.00.508), WOODWARD® IC100 series with magnetic pickup
07.70.003	MOTORTECH MIC500 series (P/N 06.00.510)
07.70.004	MOTORTECH MIC500 series (P/N 06.00.513/06.00.514), ALTRONIC® DIS & DISN, CATERPILLAR® P/N 163-6164/163-6108
07.70.005	FAIRBANKS MORSE® IQ250 series
07.70.006	ALTRONIC® CPU95 series
07.70.009	MOTORTECH MIC500 series (P/N 06.00.511)
07.70.010	MOTORTECH MIC500 series (P/N 06.00.515-6/06.00.515-8/06.00.516/06.00.517), WAUKESHA® CEC (VHP/VGF series)
07.70.011	MOTORTECH MIC3/3+ series (P/N 66.00.310-6/-12, 66.00.350-6/-12), MIC4 series (P/N 66.00.424-8/-16), MIC5 series (P/N 66.00.541-20)
07.70.012	FAIRBANKS MORSE® IQ750 series
07.70.013	MOTORTECH MIC500 series (P/N 06.00.520/06.00.525/06.00.530)
07.70.014	MOTORTECH MIC850 series
07.70.015	MOTORTECH MIC4 series (66.00.400-/410-/440-8/-16), MIC5 series (P/N 66.00.540-20/66.00.542-20)

<sup>1)</sup> Need to be ordered separately.



# Ignition Tools & Test Equipment

## Test Adaptor for MIC3/3+, MIC4 and MIC5 Series Ignition Controller

To enable operators and service personnel to check input signals to the ignition controller in a simple way, MOTORTECH offers a Test Adaptor that links between the 35 pole input connector and the appropriate harness.

Terminals located around the test box allow easy access to each input signal entering the ignition controller. By use of a commonly used Digital Scope Meter, the following signals can be checked:

- Input voltage
- Analog input signal (4-20mA)
- Pickup signals
- Start/Stop signal
- Go/NoGo signal
- Timing schedule selection switch (A/B)



## Test Adaptor for MIC3/3+, MIC4 and MIC5 Series Ignition Controllers

P/N	Supersedes	Description	For use with MOTORTECH Ignition Controllers
06.98.130		Test adaptor	MIC3/3+ series (P/N 66.00.310-6/-12, 66.00.350-6/-12) MIC4 series (P/N 66.00.424-8/-16) MIC5 series (P/N 66.00.541-20)



## ScopeLite MOTORTECH TIMING LIGHT

The self-powered ScopeLite is designed to work with fully shielded ignition systems. A special clamp picks up the small trigger signal through the braid of conventional or MOT-Blues shielded spark plug leads. The signal is processed by the timing light and via LED technology a sequence of flashes is generated. On applications where MOTORTECH ignition coils with diagnostic interface are used, the ScopeLite can be attached directly to the BNC connector of the ignition coil.

Even on applications with integral or standard flange ignition coils, the clamp can be attached to the shielded primary lead. When timing is checked on engines with non-shielded spark plug leads, a selector switch needs to be pushed which then steps down sensitivity. The automatic time based shut-off function saves the 2 built in 9 V batteries in case the operator forgets to turn off power.

Make it easy and safe for the operator!



### ScopeLite Timing Light

P/N	Description
06.98.100-200	ScopeLite timing light with LEDs, incl. clamp, 200 in. standard connecting lead and carrying case

### Connecting Leads (Standard and Non Standard Lengths) <sup>1)</sup>

P/N	Description	Length
06.90.104-100	ScopeLite connecting lead	2.5 m/100 in.
06.90.104-200	ScopeLite connecting lead	5.0 m/200 in.
06.90.104-300	ScopeLite connecting lead	7.5 m/300 in.
06.90.104-400	ScopeLite connecting lead	10.0 m/400 in.
06.90.104-600	ScopeLite connecting lead	15.0 m/600 in.

<sup>1)</sup> If non standard length is required, please order separately from above chart.

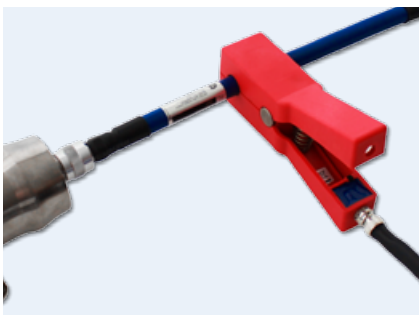

Use with MOT-Blues shielded spark plug leads.

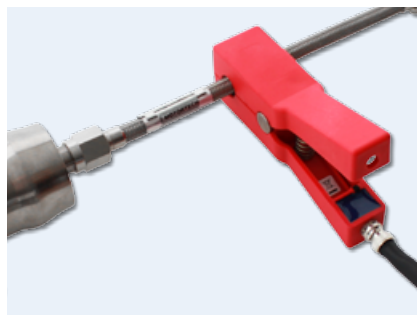

Use with conventional shielded spark plug leads.



Use with MOTORTECH ignition coils with diagnostic interface or with shielded primary lead.

# Ignition Tools & Test Equipment

## Timing Light – Conventional Style

P/N	Description	Lead Length
06.98.043-10	Timing light	3.0 m/10.0 ft.
06.98.043-30	Timing light	9.0 m/30.0 ft.



## Digital Protractor

The Digital Protractor is a compact rotational angle measuring tool. The unit is equipped with magnets for easy and flexible installation on flywheel, camshaft, pulley or any other rotating gear.

P/N	Description
06.98.096	Digital protractor



## Spark Plug Lead Removal Tool for MAN® Gas Engines

P/N	Description
44.99.918	Spark plug lead removal tool for MAN® gas engines

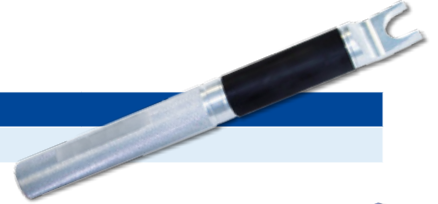

## Installation Tool for Trigger Reluctor Pin

P/N	Description
44.99.011	Installation tool for trigger reluctor pin P/N 06.80.104



## Workshop Equipment

P/N	Figure	Description
06.05.903-1	1	Spark plug test stand for M14, M18 and 7/8 in. spark plugs
06.05.904-1	2	Engine simulator with 24 ignition coil rack

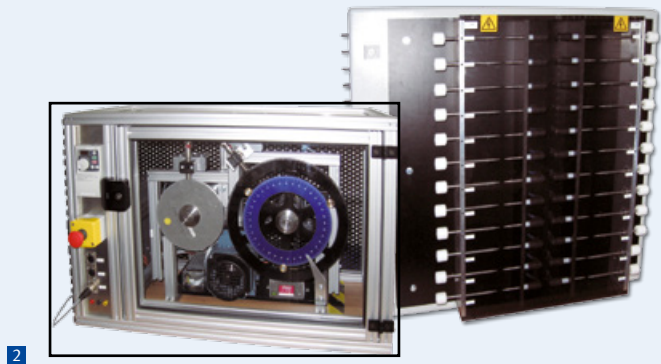



## Harness Connector Assembly Tools

P/N	Figure	Description
06.98.011	4	Crimping tool for stainless steel wire studs
06.98.017	1	Extraction tool for ITT® contacts „16S“
06.98.046	7	Installation tool for MIL style connector pins
06.98.051	6	Removal tool for MIL style connector pins

## Spark Plug Lead Assembly Tools

P/N	Figure	Description
06.98.011	4	Crimping tool for stainless steel wire studs
06.98.013	5	Crimping tool for P/N 06.80.116
06.98.019	2	Assembly tool for P/N 06.98.109
06.98.047	3	Crimping tool for P/N 06.80.126 (already includes crimping tool insert P/N 06.98.048)
06.98.048	8	Crimping tool insert for P/N 06.98.047 to crimp terminal P/N 06.80.126
06.98.050	9	Crimping tool insert for P/N 06.98.047 to crimp terminal P/N 22.85.802 and P/N 22.85.803







## ■ Spark Plugs & Accessories



Key to high reliability

### The DDI's key to long plug life

DENSO has launched the latest generation of hard-wearing spark plugs – the DENSO DOUBLE IRIDIUM (DDI) spark plug. DDI spark plug technology improves and extends the spark plug's lifespan and requires significantly less maintenance than competitor spark plugs. The DDI spark plug is particularly effective when used in biogas engines. Try DENSO DDI spark plugs today.

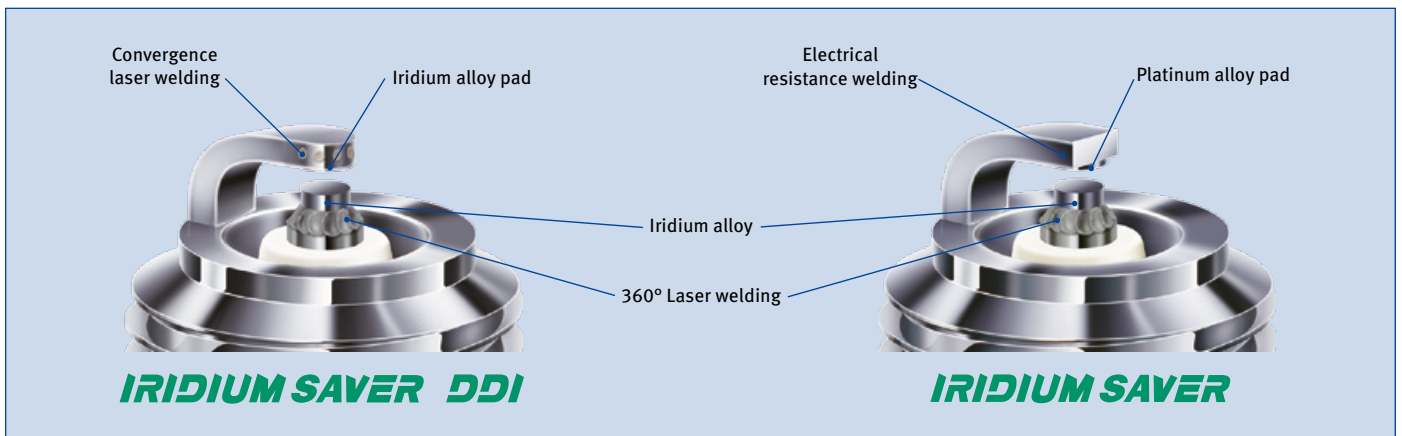

### The SAVER's key to long plug life

DENSO's OEM expertise and commitment to innovation enables them to remain at the forefront of cutting-edge gas engine spark plug development. The unique and specialist technology used in the Iridium Saver and Iridium Saver Performer spark plugs range extends their lifespan, making them ideal for high-compression lean-burn engines. Iridium Saver and Iridium Performer spark plugs also help to maximise engine performance and deliver extra durability. Because they require minimal maintenance compared to standard plugs, Iridium Saver and Iridium Saver Performer spark plugs increase service interval times.

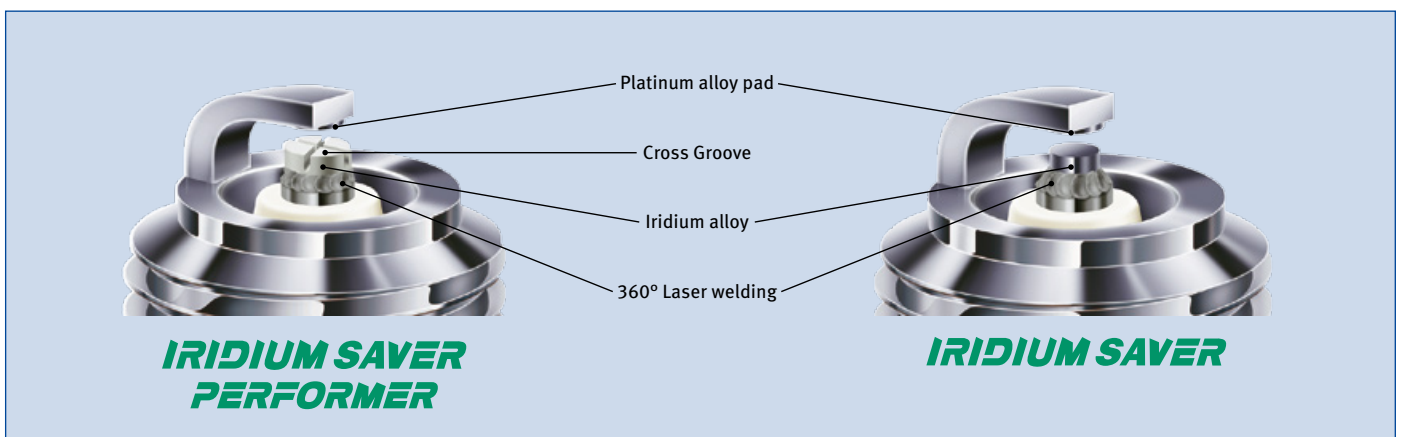

## Specifications and Cross References

for Gas Engines

**G I 3 - 1 (A)**

Installation Dimension and Tightening Torque					
No	Thread	Hex Size	Reach	Torque	
E	M14x1.25	20.8 mm	19 mm	with lubricant	20 Nm, 15 lb-ft
N			12.7 mm		
K		16 mm	19 mm	without lubricant	30 Nm, 22 lb-ft
L	M18x1.5	20.8 mm	20.6 mm	with lubricant	30 Nm, 22 lb-ft
I		22.2 mm			
T			13.8 mm		

Initial Gap	
No	Nominal Value
3	0.3 mm
5	0.5 mm

Terminal Design		
No	SPEC.	
	none	solid
	A	with nut

Electrode Design	
<ol style="list-style-type: none"> <li><b>IRIDIUM SAVER</b> Iridium pad without cross groove on center electrode and Platinum pad on ground electrode.</li> <li><b>IRIDIUM SAVER</b> For vehicle.</li> <li><b>IRIDIUM SAVER DDI</b> Iridium pad without cross groove on center electrode and Iridium pad on ground electrode.</li> </ol>	
<ol style="list-style-type: none"> <li><b>IRIDIUM SAVER PERFORMER</b> Iridium pad with cross groove on center electrode and Platinum pad on ground electrode.</li> <li><b>IRIDIUM SAVER</b> Iridium pad without cross groove on center electrode and Platinum pad on ground electrode.</li> <li><b>IRIDIUM SAVER DDI</b> Iridium pad without cross groove on center electrode and Iridium pad on ground electrode.</li> </ol>	

Spark Plugs & Accessories

## Cross References

	CHAMPION®	STITT®	ALTRONIC®	BERU®	BOSCH®	IRIDIUM SAVER	IRIDIUM SAVER DDI	IRIDIUM SAVER PERFORMER
M14	RN79G (0.015)	407XL, R407XL	J1463DP	14R-3CPU, 14-3CPU, 14R-5DPU, 14R-4CDP	7311	GE3-1	GE3-5	
				14R-4CIU (Z187), 14R-4CIU2 (Z215), 14R-4DIU2 (Z258), 14R-4DIU3, 14GZ-LL	7315		GE3-5	
	RC78PYP, RC78PYP15	407L, R407L	J1443DP	14FR-4DPUO	7321	GK3-1	GK3-5	
	RC78WYP15			14FR-4DIU, 14GZ-LL-FR	7322			
M18	RL85G, RL15B	407L, R407L	J1443DP	14R-5BPU, 14R-4ADP, 14R-5BIU		GN3-1		
	FB77WPCC, RB77WPCC, KB77WPCC, RB77CC, PB78WPC	R807LL	L1863IP	18GZ4-77, 18GZ6-77-2	7305, 7306	GI3-3	GI3-5	GI3-1
	RB75N, RB75PP			18GZ20	7302	GI3-3	GI3-5	GI3-1
	RB75WPCC-1			18GZ5-77-2	7307, 7308	GL3-3	GL3-5	GL3-1
	RB76N, RB76PP	R807LL		18GZ7		GI3-3	GI3-5	GI3-1
	RM77N	807, 827, 847, U827, U847	L1843B, L1843IP	18GZ22	7303			
RM77PP								

## ■ Spark Plugs & Accessories

### **MHP-Plugs** MOTORTECH HIGH PERFORMANCE SPARK PLUGS

The expansion of MOTORTECH's state-of-the-art ignition controllers is driven by the latest developments of modern spark ignited gas engines. The operation of these high performance engines with advanced compression rates and very efficient lean-burn combustion systems require much higher voltages to allow a perfect and effective combustion.

MHP spark plugs are designed to meet the requirements, both of modern and common engine developments and reliably deliver highest voltages and thus a strong spark down into the combustion chamber. The J-type electrode design with IRIDIUM alloy discs on center and ground electrode provides reliable combustion and increased spark plug life and helps to reduce service costs due less spark plug changes.

#### General Features

- Hot lock technology ensures increased spark plug durability even in high compression engines
- J-type electrode design for enhanced combustion
- Supplies even highest voltages of modern ignition systems like MOTORTECH's MIC series
- Long design insulators for best flashover protection
- Advanced spark erosion resistance
- Suppression of electromagnetic interference (EMI)
- Less spark plug changes reduce operation costs
- Available with different thread sizes and reaches
  - M14
  - M18
  - M22
  - 7/8-18 UNS

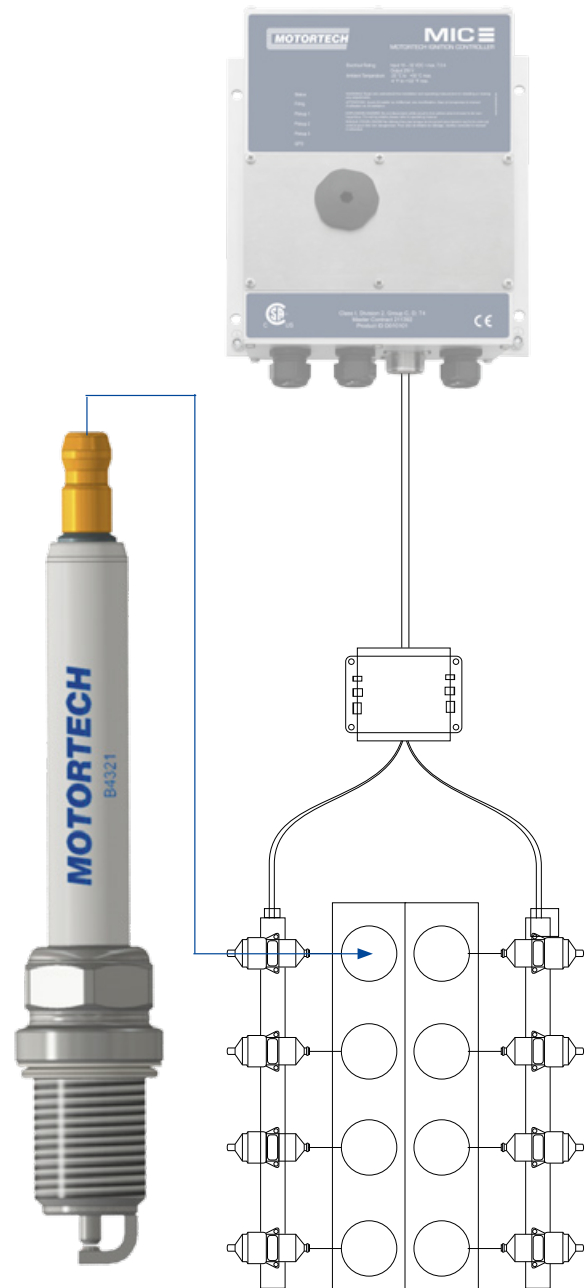

# Spark Plugs & Accessories



## Key Design Features

- 1 Removable threaded brass SAE terminal
- 2 Long aluminum oxide ceramic insulator offers best flashover protection, especially in combination with PolyMot™ spark plug leads and extensions
- 3 Integrated stress resistant monolithic resistor suppresses electromagnetic interference (EMI)
- 4 Unified hex size reduces amount of required service tools for installation
- 5 J-type electrode design and use of higher erosion resistance materials ensure better combustion particularly on lean burn gas engines and longest service life
- 6 Copper cored center electrode with laser welded IRIDIUM alloy disc
- 7 Copper cored ground electrode with laser welded IRIDIUM alloy disc

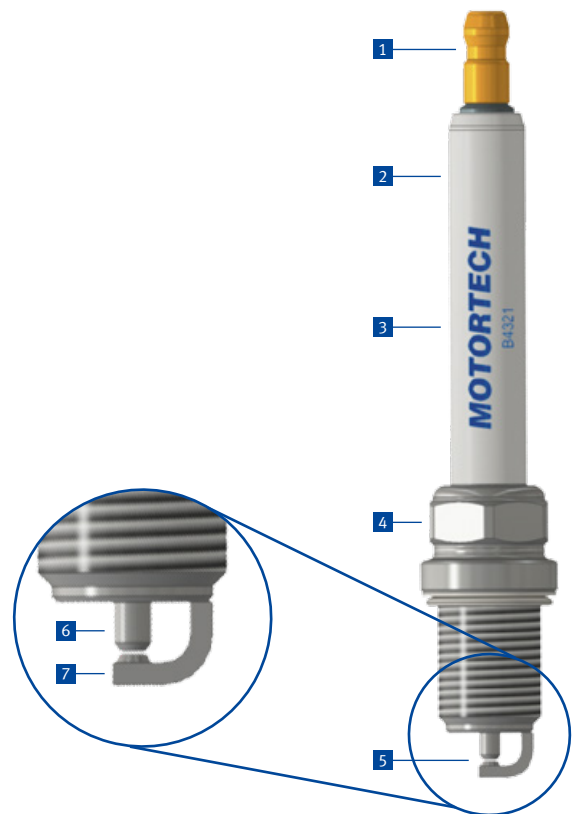

Spark Plugs & Accessories

## MOTORTECH High Performance Spark Plugs

P/N <sup>1)</sup>	Description	Thread Size	Thread Reach	Electrode Design	HEX	Equivalent to <sup>2)</sup>
B4321	MHP spark plug	M14x1.25	0.750 in. (19.0 mm)	J-type (Ir/Ir)	5/8 in. (16.0 mm)	J1463DP, 14FR-4DIU3, 14GZ6-77-2, RN79G, RC78PYP, GE3-5, GK3-5
B8124	MHP spark plug	M18x1.5	0.500 in. (12.7 mm)	J-type (Ir/Ir)	13/16 in. (20.8 mm)	L1843IP, 18GZ22, RB485-1, RM77N, RM77PP, GT3-1
B8324	MHP spark plug	M18x1.5	0.750 in. (19.0 mm)	J-type (Ir/Ir)	13/16 in. (20.8 mm)	L1863IP, 18GZ5-77-2, 18GZ6-77-2, RB75WPCC, FB77WPCC, GL3-5, GI3-5
B8524	MHP spark plug	M18x1.5	1.000 in. (25.4 mm)	J-type (Ir/Ir)	13/16 in. (20.8 mm)	
B2224	MHP spark plug	M22x1.5	0.600 in. (15.0 mm)	J-type (Ir/Ir)	13/16 in. (20.8 mm)	
B2324	MHP spark plug	M22x1.5	0.750 in. (19.0 mm)	J-type (Ir/Ir)	13/16 in. (20.8 mm)	
B2424	MHP spark plug	M22x1.5	0.875 in. (22.2 mm)	J-type (Ir/Ir)	13/16 in. (20.8 mm)	
B7224	MHP spark plug	7/8-18 UNS	0.600 in. (15.0 mm)	J-type (Ir/Ir)	13/16 in. (20.8 mm)	L2252IP, 7/8GZ9, RB212-1, RW80N
B7324	MHP spark plug	7/8-18 UNS	0.750 in. (19.0 mm)	J-type (Ir/Ir)	13/16 in. (20.8 mm)	7/8GZ11, RW78N, W18, R717
B7424	MHP spark plug	7/8-18 UNS	0.875 in. (22.2 mm)	J-type (Ir/Ir)	13/16 in. (20.8 mm)	L2282IP, RB114-1, RW77N, RW77PP, W77N

<sup>1)</sup> MOTORTECH MHP-Plugs only available in packs of 4 pcs.

<sup>2)</sup> Refer to current MHP-Plugs sales flyer for further cross references and notes.



## ■ Spark Plugs & Accessories

### MOTORTECH Extended Barrel Spark Plugs

For certain applications extended barrel plugs are required. For example when the operator cannot get a conventional spark plug down the narrow spark plug well, he will need a special product that allows him to torque the plug from the top end. MOTORTECH offers an improved product to the market. Several of the known problems of products made by competitors are eliminated.

Besides an increase in reliability the spark plug run time needed to be extended. To achieve this, MOTORTECH uses base plugs with Iridium alloy (J-type) or Nickel/Aluminum alloy (X-Type) on center and ground electrode. MOTORTECH extended barrel spark plugs can be ordered in different lengths, terminal styles or with an integrated spark plug wire.



#### Features

- No more trapped air in the extension barrel
- No more condensation
- No internal flash over
- Built in ceramics
- High dielectric strength
- Rigid welds



The **J-type** ground electrode ensures better combustion, particularly on lean burn gas engines.



The alternative **X-type** double-stage electrodes are ideally suited for slow-speed gas engines.

## XT-Plugs

MOTORTECH EXTENDED BARREL SPARK PLUGS

MOTORTECH XT-Plugs are available with three different terminal styles to be connected directly to a spark plug lead or a short integral ignition coil.

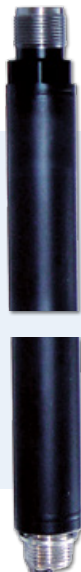

The “**S2-Type**” has a 3/4 in. male thread and used to be called the AIRCRAFT STYLE spark plug. This spark plug is designed to be connected to a shielded spark plug lead.



The “**DCP-Type**” has a female thread to adapt to a short integral ignition coil. This combination is popular in applications, where customers have had bad experiences with shielded spark plug leads.



The “**C-Type**” is an extended barrel plug that has a conventional ceramic insulator on the top end. This allows the use of a standard spark plug boot. Preferable the connector includes a 5 kΩ resistor to suppress electromagnetic interference (EMI).

# Spark Plugs & Accessories



Specification Table

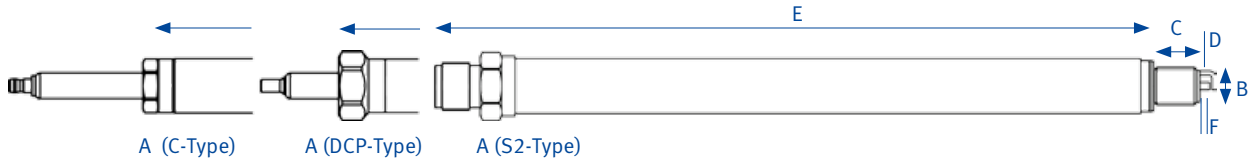

P/N A B C D E F

A	Spark Plug Style
C	C-Type – for use with spark plug lead
DCP	DCP-Type – for use with integral ignition coil
S2	S2-Type – for use with shielded spark plug lead or unshielded safety lead

B	C	D	Thread Size	Thread Reach	Electrode Design
B4	1	2	M14x1.25	0.500 in. (12.7 mm)	J-type (Ir/Ir)
B4	3	2	M14x1.25	0.750 in. (19.0 mm)	J-type (Ir/Ir)
B8	1	1	M18x1.5	0.500 in. (12.7 mm)	X-Type (Ni/Al)
B8	1	2	M18x1.5	0.500 in. (12.7 mm)	J-type (Ir/Ir)
B8	3	1	M18x1.5	0.750 in. (19.0 mm)	X-Type (Ni/Al)
B8	3	2	M18x1.5	0.750 in. (19.0 mm)	J-type (Ir/Ir)
B8	5	2	M18x1.5	1.000 in. (25.4 mm)	J-type (Ir/Ir)
B2	2	2	M22x1.5	0.600 in. (15.0 mm)	J-type (Ir/Ir)
B2	3	2	M22x1.5	0.750 in. (19.0 mm)	J-type (Ir/Ir)
B2	4	2	M22x1.5	0.875 in. (22.2 mm)	J-type (Ir/Ir)
B7	2	2	7/8-18 UNS	0.600 in. (15.0 mm)	J-type (Ir/Ir)
B7	3	2	7/8-18 UNS	0.750 in. (19.0 mm)	J-type (Ir/Ir)
B7	4	2	7/8-18 UNS	0.875 in. (22.2 mm)	J-type (Ir/Ir)

E	Extended Barrel Length – Other lengths available on request
BEX6	6 in.
BEX8	8 in.
BEX10	10 in.
BEX12	12 in.
BEX16	16 in.

*optional*

F	Electrode Gap
010	0.010 in. (0.25 mm)
012	0.012 in. (0.30 mm)
014	0.014 in. (0.35 mm)

Recommended Tightening Torque <sup>1)</sup>		
Thread Size	Tightening Torque (Cast Iron Head)	
M14x1.25	30 to 40 Nm	22 to 29 lb-ft
M18x1.5	50 to 60 Nm	37 to 44 lb-ft
M22x1.5	70 to 80 Nm	52 to 59 lb-ft
7/8-18 UNS	70 to 80 Nm	52 to 59 lb-ft

<sup>1)</sup> Please observe the tightening torques rendered by each engine manufacturer.

Conversion 1 inch = 25,4 mm / 1 foot = 0,3 m

Spark Plugs & Accessories

## Spark Plugs & Accessories

UNSHIELDED

### XTL-Plugs

MOTORTECH EXTENDED BARREL SPARK PLUGS

Based on the concept of the extended barrel spark plugs, MOTORTECH offers another style of spark plug. MOTORTECH XTL-Plugs are manufactured with an integrated 7 mm spark plug wire, which allows a direct connection to an externally mounted ignition coil.

MOTORTECH XTL-Plugs can be ordered with different barrel and lead lengths and a wide range of ignition coil connectors. This guarantees a custom-made spark plug which definitely fits your application.

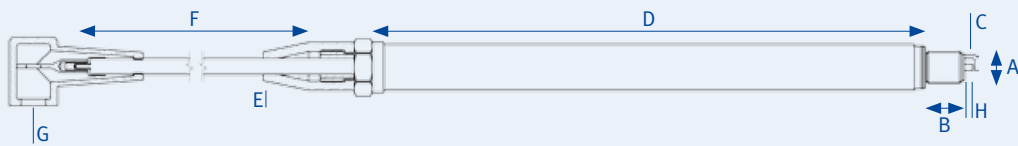

#### Available Connectors to Ignition Coil



5A = ALTRONIC® style; 5B = BENDIX® style; 5C = MOTORTECH style

Specification Table – for unshielded Applications

A	B	C	Thread Size	Thread Reach	Electrode Design
B4	1	2	M14x1.25	0.500 in. (12.7 mm)	J-type (Ir/Ir)
B4	3	2	M14x1.25	0.750 in. (19.0 mm)	J-type (Ir/Ir)
B8	1	1	M18x1.5	0.500 in. (12.7 mm)	X-Type (Ni/Al)
B8	1	2	M18x1.5	0.500 in. (12.7 mm)	J-type (Ir/Ir)
B8	3	1	M18x1.5	0.750 in. (19.0 mm)	X-Type (Ni/Al)
B8	3	2	M18x1.5	0.750 in. (19.0 mm)	J-type (Ir/Ir)
B8	5	2	M18x1.5	1.000 in. (25.4 mm)	J-type (Ir/Ir)
B2	2	2	M22x1.5	0.600 in. (15.0 mm)	J-type (Ir/Ir)
B2	3	2	M22x1.5	0.750 in. (19.0 mm)	J-type (Ir/Ir)
B2	4	2	M22x1.5	0.875 in. (22.2 mm)	J-type (Ir/Ir)
B7	2	2	7/8-18 UNS	0.600 in. (15.0 mm)	J-type (Ir/Ir)
B7	3	2	7/8-18 UNS	0.750 in. (19.0 mm)	J-type (Ir/Ir)
B7	4	2	7/8-18 UNS	0.875 in. (22.2 mm)	J-type (Ir/Ir)
D	<b>Extended Barrel Length – Other lengths available on request</b>				
BEX6	6 in.				
BEX8	8 in.				
BEX10	10 in.				
BEX12	12 in.				
BEX16	16 in.				
E	<b>Lead Output from Extended Barrel</b>				
B	180°				
F	<b>Lead Length – Other lengths available on request</b>				
8	8 in.				
10	10 in.				
12	12 in.				
14	14 in.				
16	16 in.				
18	18 in.				
G	<b>Ignition Coil Connector</b>				
1	Non CSA	ALTRONIC® Style – male, 180°			
1A	Non CSA	ALTRONIC® Style – female, 180°, with spreading adaptor			
2	Non CSA	MOTORTECH Style – M6, 90°			
3	Non CSA	ALTRONIC® Style – male, 180°			
4	Non CSA	ALTRONIC® Style – female, 90°			
5A	CSA	ALTRONIC® Style – Externally Mounted – 3/4-20 UNEF			
5B	CSA	BENDIX® Style – Externally Mounted – 3/4-20 UNEF			
5C	CSA	MOTORTECH Style – Externally Mounted – 1-20 UNEF			
6	Non CSA	ALTRONIC® Style – male, 90°			
7	Non CSA	New MOTORTECH Style – M6, 180°			
8	Non CSA	ALTRONIC® Style – female, 90°			
9	Non CSA	FAIRBANKS MORSE®-Style – male – no boot			
H	<b>Electrode Gap</b>				
010	0.010 in. (0.25 mm)				
012	0.012 in. (0.30 mm)				
014	0.014 in. (0.35 mm)				

P/N A B C D E F G H

Spark Plugs & Accessories

Recommended Tightening Torque <sup>1)</sup>		
Thread Size	Tightening Torque (Cast Iron Head)	
M14x1.25	30 to 40 Nm	22 to 29 lb-ft
M18x1.5	50 to 60 Nm	37 to 44 lb-ft
M22x1.5	70 to 80 Nm	52 to 59 lb-ft
7/8-18 UNS	70 to 80 Nm	52 to 59 lb-ft

<sup>1)</sup> Please observe the tightening torques rendered by each engine manufacturer.

*optional*

Conversion 1 inch = 25,4 mm / 1 foot = 0,3 m

## Spark Plugs & Accessories

SHIELDED

### XTL-Plugs

MOTORTECH EXTENDED BARREL SPARK PLUGS

MOTORTECH XTL-Plugs are also available for shielded applications. To meet CSA requirements, this type of spark plug is fitted with an integrated and specially designed wire. This is also known from MOTORTECH's MOT-Blues shielded spark plug leads. The multilayer design ensures that no humidity can be trapped in the wire.

MOTORTECH XTL-Plugs can be ordered with different barrel and lead lengths and suitable ignition coil connectors, to allow direct connection to a shielded ignition coil. This guarantees a custom-made spark plug which definitely fits your application.

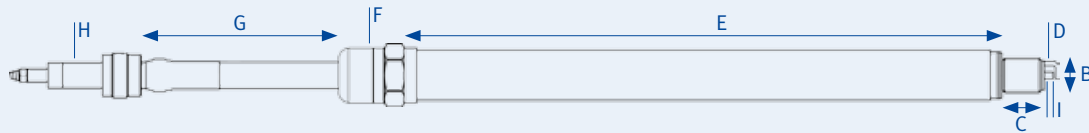

The specially designed wire consists of a multilayer design:

- Nickel plated copper core
- 2 layers of silicone
- Stainless steel braid
- Silicone jacket

Specification Table – for shielded Applications

A		Spark Plug Style	
I		Shielded Application	

B	C	D	Thread Size	Thread Reach	Electrode Design
B4	1	2	M14x1.25	0.500 in. (12.7 mm)	J-type (Ir/Ir)
B4	3	2	M14x1.25	0.750 in. (19.0 mm)	J-type (Ir/Ir)
B8	1	1	M18x1.5	0.500 in. (12.7 mm)	X-Type (Ni/Al)
B8	1	2	M18x1.5	0.500 in. (12.7 mm)	J-type (Ir/Ir)
B8	3	1	M18x1.5	0.750 in. (19.0 mm)	X-Type (Ni/Al)
B8	3	2	M18x1.5	0.750 in. (19.0 mm)	J-type (Ir/Ir)
B8	5	2	M18x1.5	1.000 in. (25.4 mm)	J-type (Ir/Ir)
B2	2	2	M22x1.5	0.600 in. (15.0 mm)	J-type (Ir/Ir)
B2	3	2	M22x1.5	0.750 in. (19.0 mm)	J-type (Ir/Ir)
B2	4	2	M22x1.5	0.875 in. (22.2 mm)	J-type (Ir/Ir)
B7	2	2	7/8-18 UNS	0.600 in. (15.0 mm)	J-type (Ir/Ir)
B7	3	2	7/8-18 UNS	0.750 in. (19.0 mm)	J-type (Ir/Ir)
B7	4	2	7/8-18 UNS	0.875 in. (22.2 mm)	J-type (Ir/Ir)

E	Extended Barrel Length – Other lengths available on request
BEX6	6 in.
BEX8	8 in.
BEX10	10 in.
BEX12	12 in.
BEX16	16 in.

F	Lead Output from Extended Barrel
B	180°

G	Lead Length – Other lengths available on request
8	8 in.
10	10 in.
12	12 in.
14	14 in.
16	16 in.
18	18 in.

H	Ignition Coil Connector
5A	CSA ALTRONIC® Style – Externally Mounted – 3/4-20 UNEF
5B	CSA BENDIX® Style – Externally Mounted – 3/4-20 UNEF
5C	CSA MOTORTECH Style – Externally Mounted – 1-20 UNEF

I	Electrode Gap
010	0.010 in. (0.25 mm)
012	0.012 in. (0.30 mm)
014	0.014 in. (0.35 mm)

Recommended Tightening Torque <sup>1)</sup>		
Thread Size	Tightening Torque (Cast Iron Head)	
M14x1.25	30 to 40 Nm	22 to 29 lb-ft
M18x1.5	50 to 60 Nm	37 to 44 lb-ft
M22x1.5	70 to 80 Nm	52 to 59 lb-ft
7/8-18 UNS	70 to 80 Nm	52 to 59 lb-ft

<sup>1)</sup> Please observe the tightening torques rendered by each engine manufacturer.

Spark Plugs & Accessories

*optional*



## ■ Spark Plugs & Accessories

# ICP-Plugs

MOTORTECH INTEGRAL IGNITION COIL SPARK PLUGS

For operators who prefer to use a long integral ignition coil, MOTORTECH manufactures the dual threaded spark plugs. For years these plugs have been successfully operated worldwide.

### General Features

- Hot lock technology ensures increased spark plug durability even in high compression engines
- J-type electrode design for enhanced combustion
- Supplies even highest voltages of modern ignition systems like MOTORTECH's MIC series
- Special isolation for ceramic insulators for best flashover protection
- Advanced spark erosion resistance
- Suppression of electromagnetic interference (EMI)
- Less spark plug changes reduce operation costs
- Available with different thread sizes and reaches
  - M14
  - M18

### Key Design Features

- 1 Additional silicone isolation on aluminum oxide ceramic insulator offers best flashover protection
- 2 Integrated stress resistant monolithic resistor suppresses electromagnetic interference (EMI)
- 3 13/16-20 UNEF top thread for coil connection with full 6 threads to meet the CSA requirements
- 4 Rigid welds
- 5 J-type electrode design and use of higher erosion resistance materials ensure better combustion particularly on lean burn gas engines and longest service life
- 6 Copper cored center electrode with laser welded Iridium alloy disc
- 7 Copper cored ground electrode with laser welded Iridium alloy disc



### Dual Threaded Spark Plugs for use with Integral Ignition Coils

P/N <sup>1)</sup>	Description	Thread Size	Thread Reach	Electrode Design	HEX	Thread Size Ignition Coil	Equivalent to
ICPB412	ICP spark plug	M14x1.25	0.500 in. (12.7 mm)	J-type (Ir/Ir)	15/16 in. (23.8 mm)	13/16-20 UNEF	RTL85G, 9Y-3985
ICPB432	ICP spark plug	M14x1.25	0.750 in. (19.0 mm)	J-type (Ir/Ir)	15/16 in. (23.8 mm)	13/16-20 UNEF	RTN79G, 4W-2256
ICPB812	ICP spark plug	M18x1.5	0.500 in. (12.7 mm)	J-type (Ir/Ir)	15/16 in. (23.8 mm)	13/16-20 UNEF	RTM77N, RTM77PP, 60999G
ICPB832	ICP spark plug	M18x1.5	0.750 in. (19.0 mm)	J-type (Ir/Ir)	15/16 in. (23.8 mm)	13/16-20 UNEF	RTB77WPCC

<sup>1)</sup> MOTORTECH ICP-Plugs only available in packs of 4 pcs.



# Spark Plugs & Accessories



## Spark Plug Cleaning Kit

Regular maintenance is required to achieve the maximum service life in particular with high price spark plugs with precious metal alloys.

Apart from readjusting the electrode gap, the spark plug should also be freed from deposits and residues that have formed during operation. By using the MOTORTECH spark plug cleaning kit these impurities can be removed easily and gently in the electrode area and on the thread within a regular maintenance interval.

This will increase spark plug service life and cut maintenance costs.

### Features

- Professional cleaning of spark plugs without pre-chamber
- Different nozzle sizes matching M14, M18, M22, and 7/8-18 spark plugs
- Oil residues and deposits in the electrode area are removed without residues by high pressure
- Special blasting grit for gentle cleaning of the electrode and thread area
- Blasting grit is captured and can be reused
- No dust development

### Scope of Delivery

The spark plug cleaning kit is supplied with the following parts:

- Spark plug cleaning device with compressed air quick release coupling, blasting grit container and dust collector bag
- Cleaning nozzles for M14, M18, M22 and 7/8-18 spark plugs
- Blasting grit, 1 kg, in separate container
- Operating manual
- Hard shell carrying case with foam insert



Spark Plugs & Accessories

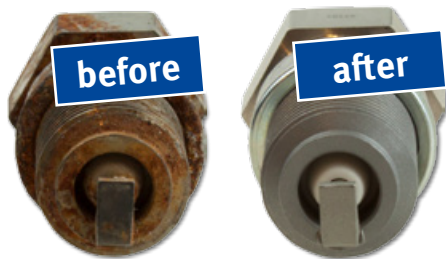

P/N	Supersedes	Description
44.01.023	44.01.000	Spark plug cleaning kit

### Subcomponents

P/N	Supersedes	Description
44.01.009		Blasting grit, 1 kg
44.01.024	44.01.005	Cleaning nozzles, kit for M14, M18, M22 and 7/8-18 spark plugs
44.01.025	44.01.006	Dust collector bag for spark plug cleaning device

# ■ Spark Plugs & Accessories

## Spark Plug Tools

### MOTORTECH Spark Plug Gap Setting Tool

The gap between the center and ground electrodes is of fundamental importance for clean combustion as well as the optimal functioning of any spark plug. During the operation of a gas engine, however, the gap between the electrodes can increase, e.g. because of spark erosion, which can lead to increased voltage requirements or even misfiring.

The electrode gap should be re-adjusted at regular maintenance intervals in order to maximize the service life of spark plugs, especially for high-priced industrial spark plugs.

#### Features

- Simple-to-use tool for setting the electrode gap on different spark plug types
- The quick-release lock of the thread adaptor ensures that spark plugs can be changed quickly
- The tool is hand-operated and does not need to be additionally mounted on a workbench
- The spark plug gap setting tool can be custom-configured with optionally available accessory components
- The tool and all accessories can be stowed in the included carrying case
- Transportable, which makes it ideal for service companies

MOTORTECH's innovative spark plug gap setting tool provides every gas engine operator or employee of a service company with a smart tool to professionally adjust the electrode gap on-site in a material-conserving manner.



### Functional Description (Example J-Type Spark Plug)



**1** The tool is first fitted with the base insert that fits the corresponding spark plug.



**2** Thread adaptors are available in various sizes for the spark plugs that need to be set (M14, M18, 7/8-18 or M22). The adaptors can be mounted or exchanged easily with the included screws and the hex key.



**3** The integrated quick-release lock guarantees rapid changes and secure holding of the spark plugs while they are being set.



**4** Light pressure on the lever is enough to set the electrode gap to the desired distance with the help of a feeler gauge.

## Basic Kits <sup>1)</sup>

P/N	Figure	Supersedes	Description
07.98.120-14	1	07.98.113	Spark plug gap setting tool, basic kit including thread adaptor for spark plugs with M14x1.25 thread
07.98.120-18	1	07.98.113	Spark plug gap setting tool, basic kit including thread adaptor for spark plugs with M18x1.5 thread
07.98.120-78	1	07.98.113	Spark plug gap setting tool, basic kit including thread adaptor for spark plugs with 7/8-18 UNS and M22x1.5 thread

<sup>1)</sup> Needs appropriate accessory kit in addition.

## Thread Adaptors <sup>1)</sup>

P/N	Figure	Supersedes	Description
07.98.121-14	2		Thread adaptor for spark plugs with M14x1.25 thread
07.98.121-18	2		Thread adaptor for spark plugs with M18x1.5 thread
07.98.121-78	2		Thread adaptor for spark plugs with 7/8-18 UNS and M22x1.5 thread

<sup>1)</sup> Can be ordered separately in addition to chosen basic kit.

## Accessory Kits <sup>1)</sup>

P/N	Figure	Supersedes	Description
07.98.122-A	3		Accessory kit for J-type spark plugs
07.98.122-B	3		Accessory kit for CHAMPION® N-type spark plugs
07.98.122-C	3		Accessory kit for BERU® spark plugs 18GZ44 (Z283), Super Blue Ignition (Z351)
07.98.122-D	3		Accessory kit for BERU® spark plug 18GZ46 (Z377)
07.98.122-E	3		Accessory kit for BERU® spark plug 18GZ47
07.98.122-F	3		Accessory kit for bridge spark plugs MBP1800, CHAMPION® FB78WW, ROLLS ROYCE® 710875

<sup>1)</sup> Need to be ordered separately in addition to chosen basic kit.

## Feeler Gauges

P/N	Figure	Supersedes	Description	Size
07.98.131	4		Feeler gauge, 8 blades	0.002 to 0.020 in. (0.05 to 0.50 mm)
07.98.037	5		Feeler gauge clamp tool	
07.98.059	6		Feeler gauge shim roll, 12.7 mm x 5.0 m	0.008 in. (0.20 mm)
07.98.034	6		Feeler gauge shim roll, 12.7 mm x 5.0 m	0.010 in. (0.25 mm)
07.98.035	6		Feeler gauge shim roll, 12.7 mm x 5.0 m	0.012 in. (0.30 mm)
07.98.036	6		Feeler gauge shim roll, 12.7 mm x 5.0 m	0.014 in. (0.35 mm)



## Spark Plugs & Accessories

### Extended Barrel Magnetic Spark Plug Sockets – Standard Versions

P/N <sup>1)</sup>	Supersedes	Description	HEX	Drive
07.99.022-5-L		Magnetic spark plug socket	5/8 in. (16.0 mm)	1/2 in.
07.99.022-4-L	07.99.018-L	Magnetic spark plug socket	13/16 in. (20.8 mm)	1/2 in.
07.99.022-3-L	07.99.019-L	Magnetic spark plug socket	7/8 in. (22.2 mm)	1/2 in.
07.99.022-2-L	07.99.020-L	Magnetic spark plug socket	15/16 in. (23.8 mm)	1/2 in.
07.99.022-1-L	07.99.021-L	Magnetic spark plug socket	1 in. (25.4 mm)	1/2 in.

<sup>1)</sup> Standard barrel lengths („L“) = 6 in., 12 in., 16 in., 18 in. Other lengths available on request.



### Extended Barrel Magnetic Spark Plug Sockets – Special Versions

P/N	Supersedes	Description	HEX	Drive
07.99.022-3-36		Magnetic spark plug socket – NORDBERG®	7/8 in. (22.2 mm)	1/2 in.
07.99.022-6-6		Magnetic spark plug socket – MAN® E28 series	13/16 in. (20.8 mm)	1/2 in.

### Spark Plug Socket for MOTORTECH XTL-Plugs

P/N	Supersedes	Description	HEX	Drive
07.99.022-6-2		Spark plug socket	7/8 in. (22.2 mm)	1/2 in.



### Torque Wrench

P/N	Supersedes	Description	Torque	Drive
07.98.065	07.98.063	Torque wrench	7.4 to 74 lb-ft (10 to 100 Nm)	1/2 in.



## Spark Plugs & Accessories



### Seat & Thread Reconditioners

Use seat & thread reconditioner to clean cylinder threads and gasket seats in one operation.

P/N	Supersedes	Description	Thread Size	Thread Reach
07.98.114-12	07.98.022	Seat & thread reconditioner	M14x1.25	1/2 in.
07.98.114-34	07.98.023	Seat & thread reconditioner	M14x1.25	3/4 in.
07.98.118-12	07.98.024	Seat & thread reconditioner	M18x1.5	1/2 in.
07.98.118-34	07.98.025	Seat & thread reconditioner	M18x1.5	3/4 in.
07.98.178-58	07.98.026	Seat & thread reconditioner	7/8-18 UNS	5/8 in.
07.98.178-78	07.98.026-1	Seat & thread reconditioner	7/8-18 UNS	7/8 in.



### Extended Barrel Seat & Thread Reconditioners – 1/2 Inch Drive

P/N	Supersedes	Description	Thread Size	Thread Reach
07.98.114-12-BEX6		Seat & thread reconditioner, 6 in. length	M14x1.25	1/2 in.
07.98.114-12-BEX12		Seat & thread reconditioner, 12 in. length	M14x1.25	1/2 in.
07.98.114-34-BEX6		Seat & thread reconditioner, 6 in. length	M14x1.25	3/4 in.
07.98.114-34-BEX12		Seat & thread reconditioner, 12 in. length	M14x1.25	3/4 in.
07.98.118-12-BEX6		Seat & thread reconditioner, 6 in. length	M18x1.5	1/2 in.
07.98.118-12-BEX12		Seat & thread reconditioner, 12 in. length	M18x1.5	1/2 in.
07.98.118-34-BEX6		Seat & thread reconditioner, 6 in. length	M18x1.5	3/4 in.
07.98.118-34-BEX12		Seat & thread reconditioner, 12 in. length	M18x1.5	3/4 in.
07.98.178-58-BEX6		Seat & thread reconditioner, 6 in. length	7/8-18 UNS	5/8 in.
07.98.178-58-BEX12		Seat & thread reconditioner, 12 in. length	7/8-18 UNS	5/8 in.
07.98.178-78-BEX6		Seat & thread reconditioner, 6 in. length	7/8-18 UNS	7/8 in.
07.98.178-78-BEX12		Seat & thread reconditioner, 12 in. length	7/8-18 UNS	7/8 in.



Spark Plugs & Accessories

### Installation & Service Kit for MOTORTECH XTL-Plugs

Spark plugs play a crucial role in an ignition system. Maintenance and, in particular, the correct handling of spark plugs is vital to ensure flawless functioning and long

service life. MOTORTECH provides an installation and service kit that is specifically designed for XTL-Spark Plugs with integrated ignition cable and M14 thread.

P/N	Supersedes	Description	For Spark plugs with	
			Thread Size	Thread Reach
07.98.214-34		Installation & service kit for MOTORTECH XTL-Plugs	M14x1.25	3/4 in.

# Spark Plugs & Accessories

## Spark Plug Accessories

### Gaskets for Spark Plugs

P/N	Description	For Thread Size	Quantity
02.85.015-100	Spark plug gasket	M14x1.25	100 pcs.
02.85.016-100	Spark plug gasket	M18x1.5	100 pcs.
02.85.017-100	Spark plug gasket	M22x1.5, 7/8-18 UNS	100 pcs.



Spark plug gaskets just once provide an optimal seal between spark plug and seat. Spark plugs must be installed with a new gasket after every service in order to ensure the best possible seal in future operation.

### Gaskets for MOTORTECH ICP-Plugs

P/N	Description	Quantity
75.90.295-100	Spark plug gasket, copper	100 pcs.



### Thread Lubricant

This lubricant is non-metallic and non-conductive. Guarantees easy spark plug removal and prevents thread damage. Also for use with seat & thread reconditioner.

P/N	Description	Equivalent to
07.98.718	Thread lubricant, 4 oz (115 g)	A718



# NOTES

---

---

---

---

---

---

---

---

---

---

---

---

---

---

---

---

---

---

---

---

---

---

---

---

---

---

---

---

---

---



# Gas Engine Control Systems

## DetCon

MOTORTECH DETONATION CONTROL SYSTEM

The gas engine operators are calling for increased power output from their engines. More load means higher temperatures, pressures and tougher operation. This mostly ends in catastrophic engine damages due to detonation or pre-ignition.

As MOTORTECH has proven for years, detonation can be detected professionally with the DetCon2 or DetCon20. Single cylinder sensors constantly monitor the sound level of the combustion chamber. If detonation is detected the system will take steps to eliminate detonation immediately.

Upgrade your engines and increase availability of the equipment!

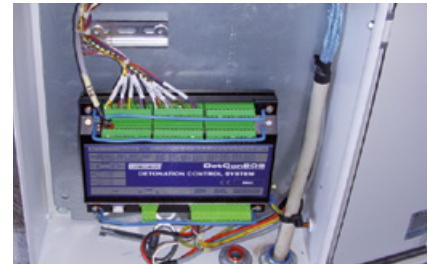

### Detonation Sensor

Can be installed on cylinder head screw or stud.  
Measures the detonation signal and transfers it to the controller.



### Detonation Software

DetCon comes with a WINDOWS® based software package that allows the operator to analyze all data in real time on his PC.



### Function

Once the controller detects soft detonation on one of the sensors (this is a specific stage before real detonation occurs), several steps will take place:

- Alarm signal turns on
- Ignition retard by 0 to 5 V or 4 to 20 mA analog output.
- If this action does not cure the detonation, the load reduction output will be activated.
- If the load drop does not stop the engine from detonating the engine STOP output will be activated.



... THIS FROM HAPPENING!

# Gas Engine Control Systems

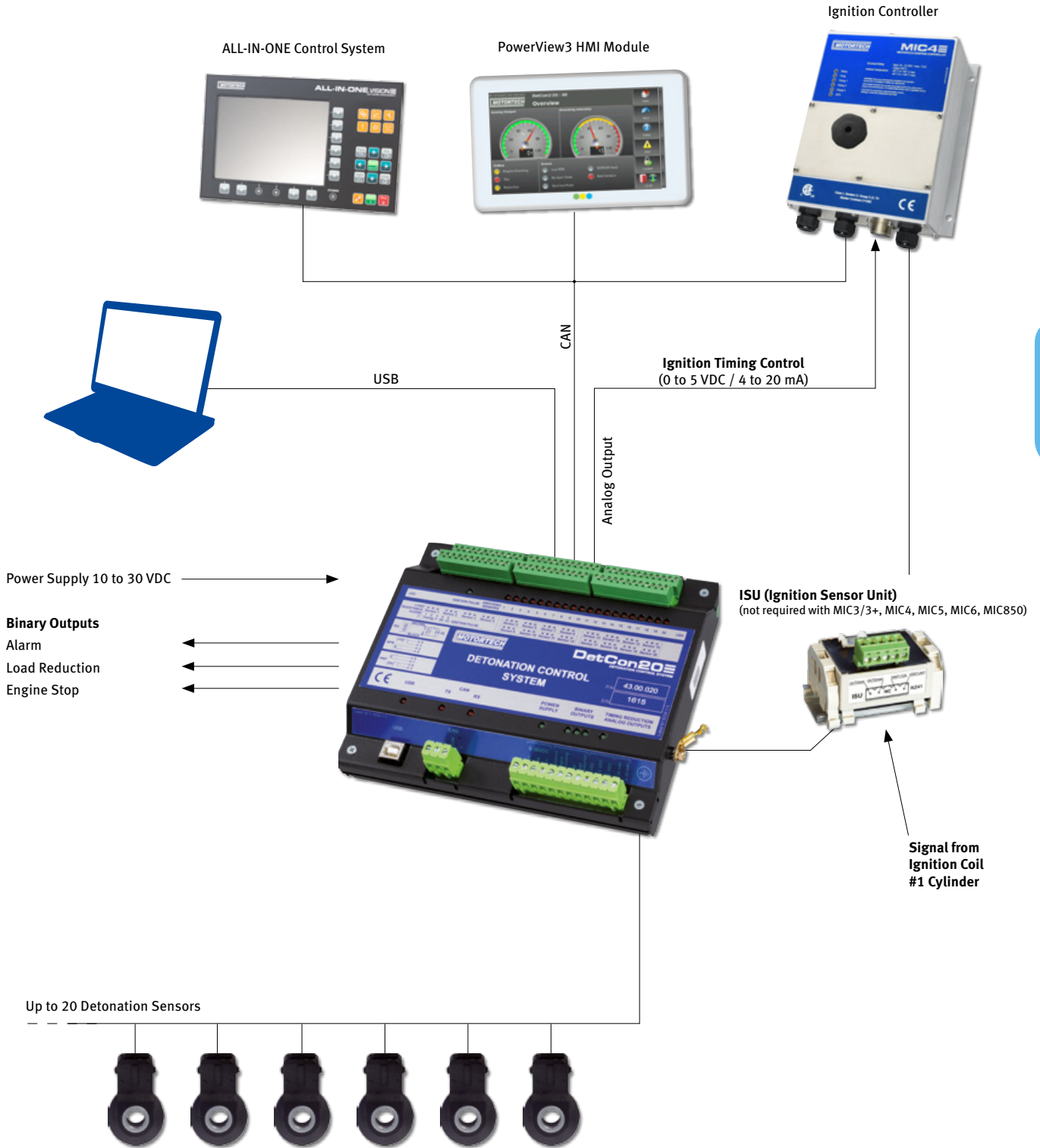

Gas Engine Control Systems

# Gas Engine Control Systems

## DetCon20 Control Units



P/N	Description
43.00.020 <sup>1)</sup>	DetCon20 control unit, 20 inputs, CSA, IP20
43.00.120	DetCon20 control unit, 20 inputs, built into an CSA enclosure, includes ISU ignition sensor unit P/N 43.20.002
43.00.220 <sup>2)</sup>	DetCon20 control unit, 20 inputs, built into an CSA enclosure



<sup>1)</sup> The control unit has to be installed in (CSA approved) control panel or enclosure.

<sup>2)</sup> For use with MIC3/3+, MIC4, MIC5, MIC6 and MIC850 series ignition controllers. Ignition sensor unit is not required.

## DetCon20 Detonation Control Kits



P/N <sup>1)</sup>	Description
43.00.020-04	DetCon20 detonation control kit, incl. DetCon20 control unit, detonation sensor lead P/N 43.30.004-60 (4 pcs.), detonation sensor P/N 43.20.001 (4 pcs.)
43.00.020-06	DetCon20 detonation control kit, incl. DetCon20 control unit, detonation sensor lead P/N 43.30.004-60 (6 pcs.), detonation sensor P/N 43.20.001 (6 pcs.)
43.00.020-08	DetCon20 detonation control kit, incl. DetCon20 control unit, detonation sensor lead P/N 43.30.004-60 (8 pcs.), detonation sensor P/N 43.20.001 (8 pcs.)
43.00.020-12	DetCon20 detonation control kit, incl. DetCon20 control unit, detonation sensor lead P/N 43.30.004-60 (12 pcs.), detonation sensor P/N 43.20.001 (12 pcs.)
43.00.020-16	DetCon20 detonation control kit, incl. DetCon20 control unit, detonation sensor lead P/N 43.30.004-60 (16 pcs.), detonation sensor P/N 43.20.001 (16 pcs.)
43.00.020-20	DetCon20 detonation control kit, incl. DetCon20 control unit, detonation sensor lead P/N 43.30.004-60 (20 pcs.), detonation sensor P/N 43.20.001 (20 pcs.)

<sup>1)</sup> If required, ISU ignition sensor unit needs to be ordered separately.

## DetCon2 Control Units



P/N	Description
43.00.002 <sup>1)</sup>	DetCon2 control unit, 2 inputs, CSA, IP20
43.00.102	DetCon2 control unit, 2 inputs, built into an CSA enclosure, includes ISU ignition sensor unit P/N 43.20.002
43.00.202 <sup>2)</sup>	DetCon2 control unit, 2 inputs, built into an CSA enclosure



<sup>1)</sup> The control unit has to be installed in (CSA approved) control panel or enclosure.

<sup>2)</sup> For use with MIC3/3+, MIC4, MIC5, MIC6 and MIC850 series ignition controllers. Ignition sensor unit is not required.

## Detonation Sensor Lead (1 per Detonation Sensor required)

P/N	Description
43.30.004-60	Detonation sensor lead, 60 ft. (18 m)



## Detonation Sensor (1 per Cylinder required)

P/N	Description
43.20.001	Detonation sensor w/o lead, 2 pole



## Engine Specific Cylinder Head Screws prepared for Detonation Sensor (1 per Cylinder required) <sup>1)</sup>

P/N	Description	Application
236-0484-DS	Cylinder head screw CATERPILLAR® P/N 236-0484, prepared, incl. mounting screw for detonation sensor	CATERPILLAR® G3406, G3408, G3408C, G3412, G3412C
51.900200381-M	Cylinder head screw MAN® P/N 51.90020-0381, prepared, incl. mounting screw for detonation sensor	MAN® E08 series
51.904900022-M	Cylinder head screw MAN® P/N 51.90490-0022, prepared, incl. mounting screw for detonation sensor	MAN® E28 series
169994B-DS	Cylinder head screw WAUKESHA® P/N 169994B, prepared, incl. mounting screw for detonation sensor	WAUKESHA® VHP series
305948A-DS	Cylinder head screw WAUKESHA® P/N 305948A, prepared, incl. mounting screw for detonation sensor	WAUKESHA® VGF series

<sup>1)</sup> Please observe the installation instructions rendered by each engine manufacturer.

## Detonation Sensor Adaptor for MWM®/DEUTZ® 604/620 Series Gas Engines (1 per Detonation Sensor required)

P/N	Description
43.20.018	Detonation sensor adaptor

## ISU Ignition Sensor Unit (1 per System required) <sup>1)</sup>

P/N	Description
43.20.002	ISU ignition sensor unit



<sup>1)</sup> Not required if MIC3/3+, MIC4, MIC5, MIC6, MIC850 or DetCon20 control unit P/N 43.00.102 or 43.00.120 is used.

## PowerView3 MOTORTECH ENGINE INFORMATION MONITOR

### Detonation Control Visualization

The operating data of the DetCon Detonation Control system will be completely visualized via HMI module (Human Machine Interface). The overview screen shows the relevant information as engine knocking, knock intensity and status for activated load reduction or emergency shutdown of engine.

The control keys guarantee simple navigation through the different display pages and menus. All in all the PowerView3 HMI module is also able to provide error diagnostics on-site without requiring a laptop!

The PowerView3 is also available for data visualization of:

- MIC Ignition Control (MIC3/3+, MIC4 and MIC5 series)
- TempScan20 Temperature Module

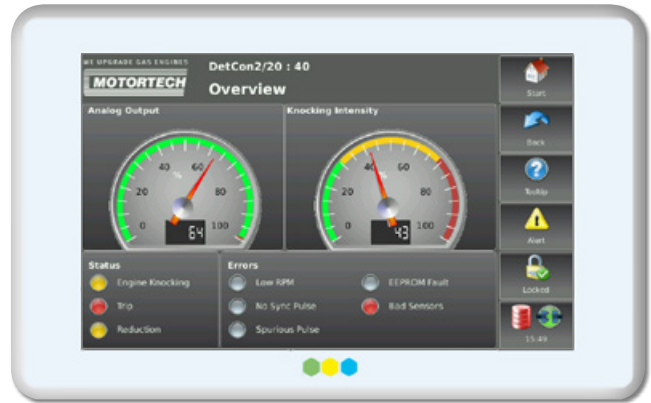

1

Gas Engine Control Systems

### Sample Screens



#### Overview

Screen shows the most important operating data of the connected DetCon control unit.

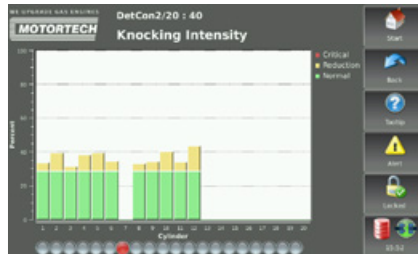

#### Knocking Intensity

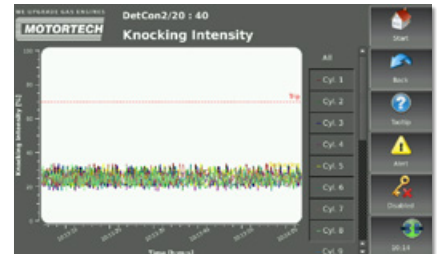

Visualization of knocking intensity of each monitored cylinder. Different colors inform about the system status (Normal – Reduction – Critical).



#### Trending Knocking Intensity

Visualization of knocking intensity trend data for each individual cylinder.

### PowerView3 HMI Modules & Activation Codes

P/N	Figure	Description
06.05.085		PowerView3 HMI module
06.05.185		PowerView3 HMI module, built into stainless steel enclosure
06.05.087-F		PowerView3 activation code for visualization of DetCon data – Activation code has to be ordered separately with each PowerView3 HMI module
06.05.087-U		PowerView3 activation code for visualization of DetCon data – Only available for upgrade of existing PowerView3 HMI module in the field



2



# Gas Engine Control Systems



## Wiring Rail System for Detonation Control

MOTORTECH stainless steel, vibration resistant rail assembly will withstand any harsh environment commonly found in oil & gas industry. The proven design is made for engine manufacturers and the global aftermarket. Do not go low-tech and take the risk of engine down time because of equipment being under repair. Eliminate the need for constant rewiring, connector exchanges or straightening out weak and bent aluminum wiring rails.

- Made of stainless steel which performs better than aluminum in harsh environments (and where operators use any kind of equipment to hold or stand on)
- Made to perfectly fit the application
- Rigid military style connectors are securely fastened into the stainless steel
- Rails are filled with special foam to ensure that all wires are separated from ground and will not vibrate and eventually short out to ground
- Water proof design – built to last in uncovered environment
- Repairable by MOTORTECH's assigned distributors in the event of mechanically damage

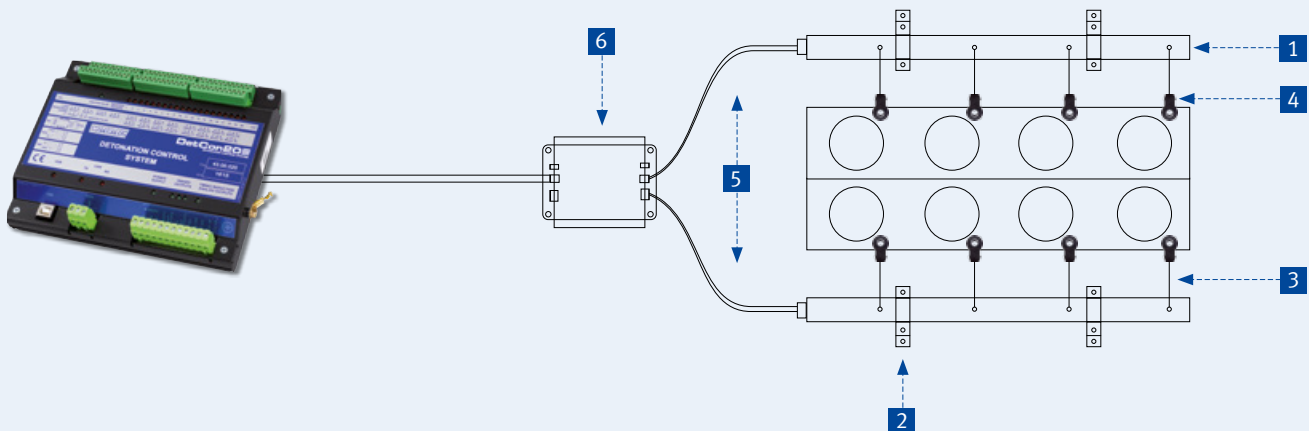
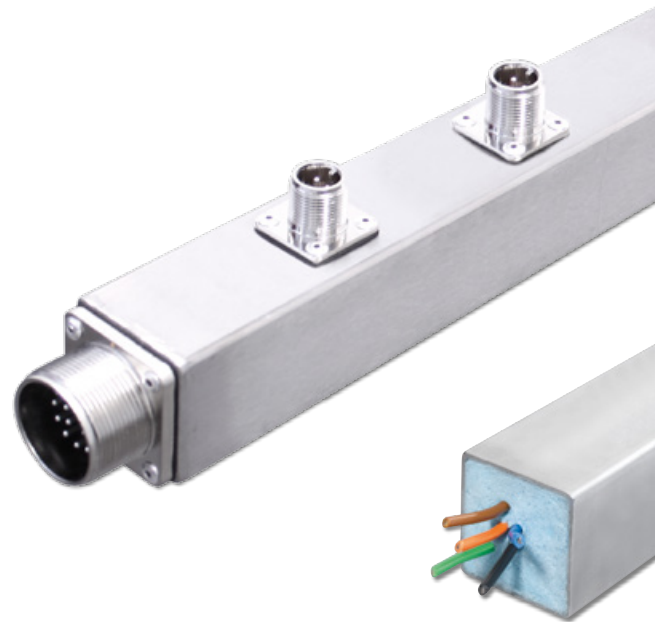
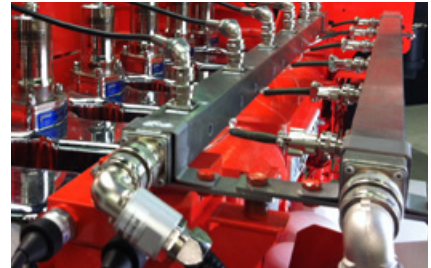

## 1 AlphaRail for Detonation Control – Specification Table

		P/N 77.8					
		A	B	C	D	E	F
<b>A</b>	<b>Sensor System</b>	[Diagram showing connections from A, B, C, D, E, F to various sensor system options]					
1	Detonation control						
<b>B</b>	<b>Number of Detonation Sensors per Bank</b>	[Diagram showing connections from B to various sensor counts]					
1	Special version						
2	2 detonation sensors						
3	3 detonation sensors						
4	4 detonation sensors						
5	5 detonation sensors						
6	6 detonation sensors						
8	8 detonation sensors						
<b>CD</b>	<b>Distance between the Detonation Sensors</b>	[Diagram showing connections from CD to various distances]					
04	4 in.						
06	6 in.						
07	7 in.						
08	8 in.						
10	10 in.						
11	11 in.						
12	12 in.						
13	13 in.						
14	14 in.						
16	16 in.						
27	27 in.						
33	33 in.						
<b>E</b>	<b>Output Design</b>	[Diagram showing connections from E to output design options]					
D	MIL, 3 pole, pin						
<b>F</b>	<b>Double Rail <sup>1)</sup> – Length of Flex Conduit</b>	[Diagram showing connections from F to various conduit lengths]					
A	NO Double Rail						
B	12 in.						
C	16 in.						
D	20 in.						
E	24 in.						
F	32 in.						
G	40 in.						
H	52 in.						

<sup>1)</sup> Two wiring rails connected by flex conduit.

# Gas Engine Control Systems

## 2 Bracket Configuration

P/N <sup>1)</sup>	Figure	Description
75.10.303	2A	Bracket, 40x40 mm (Standard)
75.10.097	2B	Flat bar, 180° (Standard)
75.10.120	2C	Flat bar, 150°
75.10.280	2D	Flat bar, 90°

<sup>1)</sup> For packs of ten please add suffix "-10" to part number.

## 3 Leads to connect Wiring Rail and Detonation Sensor (1 per Sensor required)

P/N	Figure	Description	Sensor Connector	Wiring Rail Connector	Length <sup>1)</sup>
43.30.016-25	3A	Detonation sensor lead	2 pole, socket, 180°	MIL, 3 pole, socket, 180°	25 in.
43.30.016-30	3A	Detonation sensor lead	2 pole, socket, 180°	MIL, 3 pole, socket, 180°	30 in.
43.30.016-40	3A	Detonation sensor lead	2 pole, socket, 180°	MIL, 3 pole, socket, 180°	40 in.

<sup>1)</sup> Other lengths available on request.

## 4 Detonation Sensor (1 per Cylinder required)

P/N	Figure	Description
43.20.001	4	Detonation sensor w/o lead, 2 pole





## 5 Harnesses to connect Wiring Rail and DetCon Control Unit (1 per Rail required)

P/N	Figure	Description	Wiring Rail Connector	Length
77.41.117-L	5A	Harness	MIL, 17 pole, pin, 180°	"L" = 5/15/25/50 ft.
77.41.317-L	5B	Harness	MIL, 17 pole, pin, 90°	"L" = 5/15/25/50 ft.

## 6 Accessories

P/N	Figure	Description
15.07.134	6A	Flex conduit, 3/4 in., black <sup>1)</sup>
15.07.231	6B	Fitting, 3/4 in., junction box to flex conduit
06.05.075	6C	Junction box



<sup>1)</sup> Flex conduit needs to be ordered in m/ft. in required quantity.

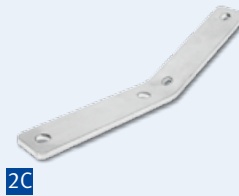
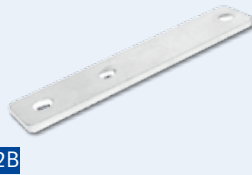
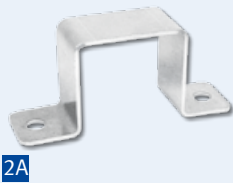

# Gas Engine Control Systems

## TempScan20 MOTORTECH TEMPERATURE MODULE



### Temperature Module with 20 Channels

The TempScan20 temperature module monitors up to 20 thermocouples and provides the temperature information to the PowerView3 HMI module via CANopen.

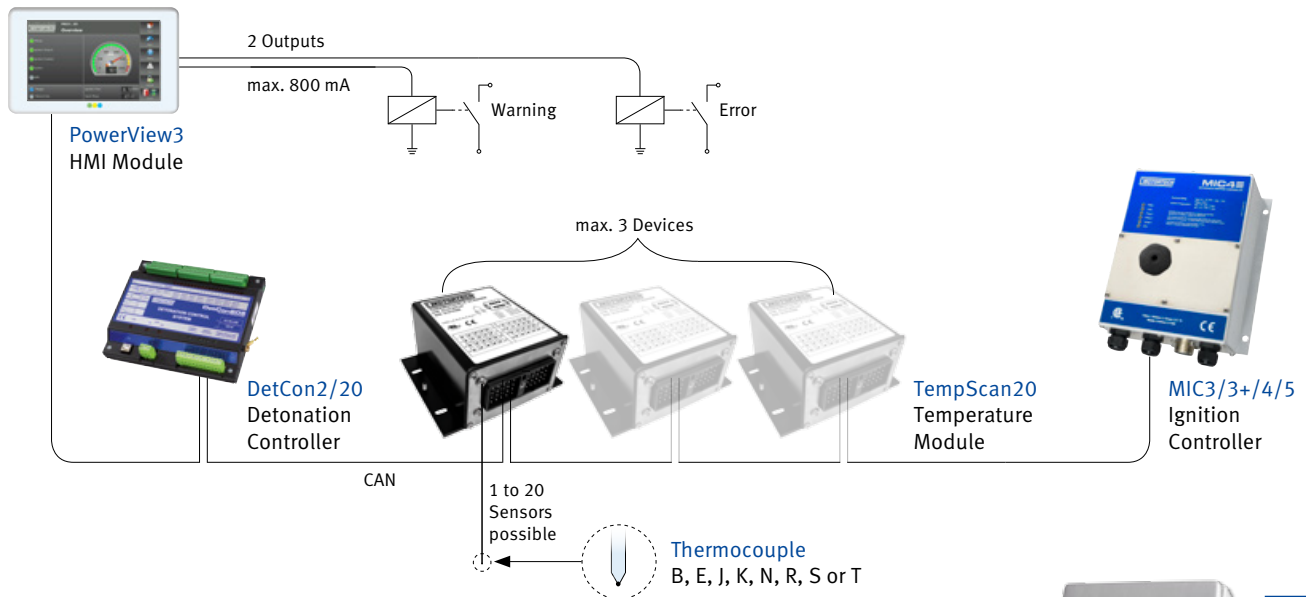
- Channels are independently configurable as Type J, K, B, E, N, R, S or T thermocouples
- Temperature information can include
  - ▶ Exhaust temperature
  - ▶ Winding temperature
  - ▶ Fluid temperature
- No additional programming or configuration required
- Integral diagnostics determine thermocouple integrity
- All channels are fully isolated from the CAN line and from the power supply
- The temperature module features rugged packaging and watertight connectors for an IP65 rating



### TempScan20 Temperature Module

P/N	Figure	Description
63.03.002-20		TempScan20 temperature module, including connector package for power supply, CAN Bus and thermocouple wiring, operating manual
63.03.012-20		TempScan20 temperature module, built into stainless steel enclosure, including connector package for power supply, CAN Bus and thermocouple wiring, operating manual



## PowerView3 MOTORTECH ENGINE INFORMATION MONITOR

### Temperature Module Visualization

The operating data of the TempScan20 temperature module will be completely visualized via HMI module (Human Machine Interface). The overview screen shows the relevant information as combustion chamber temperature individually by cylinder or status of programmed temperature thresholds (Low – Normal – High – Switching Digital Output).

The control keys guarantee simple navigation through different display pages and menus. All in all the PowerView3 HMI module is also able to provide error diagnostics on-site without requiring a laptop!

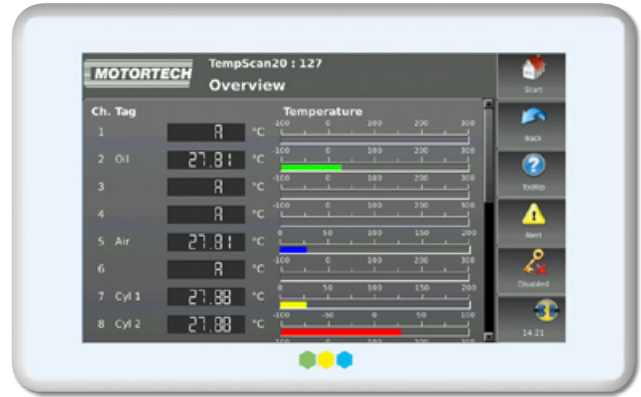

1

The PowerView3 is also available for data visualization of:

- MIC Ignition Control (MIC3/3+, MIC4 and MIC5 series)
- DetCon Detonation Control

Gas Engine Control Systems

### Sample Screens

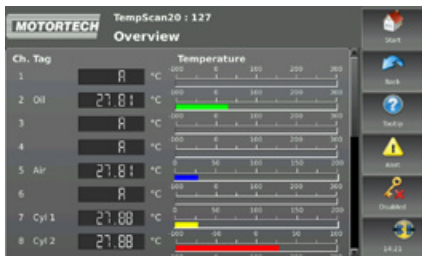

#### Overview

Screen shows the currently measured temperatures individually for each programmed channel/cylinder. Different colored gauges inform about programmed temperature thresholds (Low – Normal – High – Switching Digital Output).



#### Channel Settings

Channels can be configured individually and include options like user defined channel names, thermocouple type and temperature thresholds.

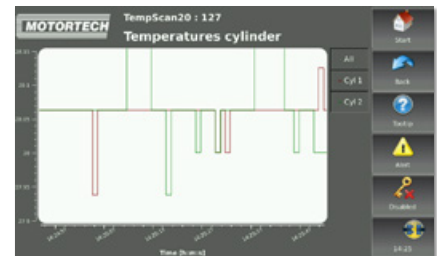

#### Trending Cylinder Temperatures

Visualization of temperature trend data for each individual cylinder.

### PowerView3 HMI Modules & Activation Codes

P/N	Figure	Description
06.05.085	1	PowerView3 HMI module
06.05.185	2	PowerView3 HMI module, built into stainless steel enclosure
06.05.088-F		PowerView3 activation code for visualization of TempScan data – Activation code has to be ordered separately with each PowerView3 HMI module
06.05.088-U		PowerView3 activation code for visualization of TempScan data – Only available for upgrade of existing PowerView3 HMI module in the field



2

# Gas Engine Control Systems



## Wiring Rail System for Temperature Control

The stainless steel wiring rails which are water tight due to a well approved foaming process, offer an easy and fast installation of accessory control systems such as

- Pyrometer/temperature control
- Gas valve systems

With individual outlet port connectors, the sensors can be individually connected and easily wired to the rail. A disconnectable main harness routs all sensors to one main control unit or individual wiring boxes.

### Details on the Pyrometer/ Thermocouple Wiring Rail:

- Up to 10 thermocouple inputs per rail
- As standard each rail comes with 2 additional thermocouple inputs for temperature measurement pre and post turbocharger
- All thermocouples need to be Type K (NiCrNi)
- Made of stainless steel which performs better than aluminum in harsh environments (and where operators use any kind of equipment to hold or stand on)
- Made to perfectly fit the application
- Rigid military style connectors are securely fastened into the stainless steel

- Rails are filled with special foam to ensure that all wires are separated from ground and will not vibrate and eventually short out to ground
- Water proof design – built to last in uncovered environment
- Repairable by MOTORTECH’s assigned distributors in the event of mechanical damage

### General Details:

- Low voltage signals can be grouped in one rail. It is not recommended to have low and high voltage signals in one rail. In this case, detonation sensor and thermocouple leads match perfectly.
- Ignition and gas valve control wire work together well.

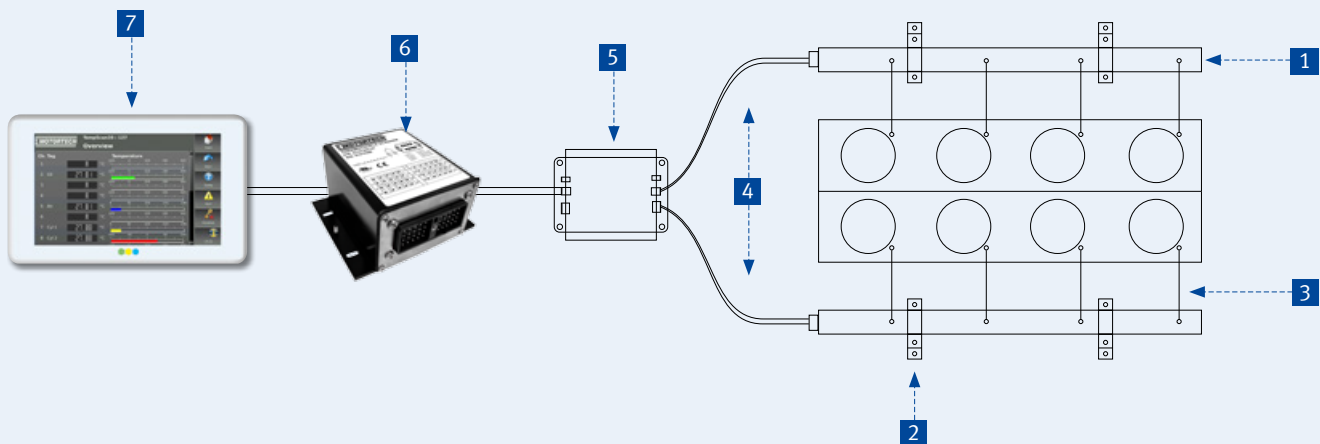
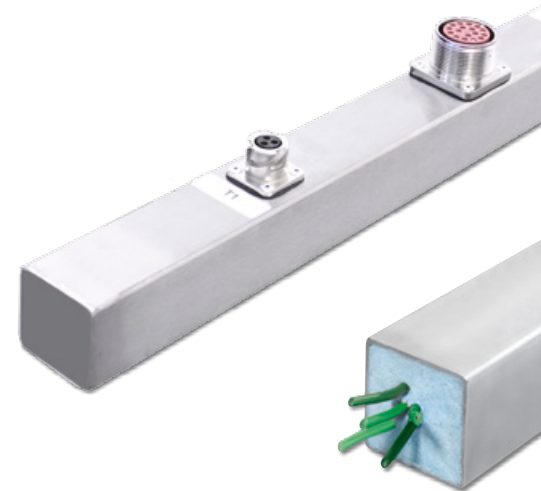

## 1 AlphaRail for Temperature Control – Specification Table

		P/N 77.8					
		A	B	C	D	E	F
<b>A</b>	<b>Sensor System</b>						
2	Temperature control						
<b>B</b>	<b>Number of Thermocouples per Bank <sup>1)</sup></b>						
1	Special version						
2	2 thermocouples						
3	3 thermocouples						
4	4 thermocouples						
5	5 thermocouples						
6	6 thermocouples						
8	8 thermocouples						
10	10 thermocouples						
<sup>1)</sup> As standard each rail includes 2 additional thermocouple inputs for temperature measurement pre and post turbocharger.							
<b>CD</b>	<b>Distance between the Thermocouples</b>						
04	4 in.						
06	6 in.						
07	7 in.						
08	8 in.						
10	10 in.						
11	11 in.						
12	12 in.						
13	13 in.						
14	14 in.						
16	16 in.						
27	27 in.						
33	33 in.						
<b>E</b>	<b>Output Design</b>						
H	MIL, 3 pole, socket, bayonet						
<b>F</b>	<b>Double Rail <sup>1)</sup> – Length of Connecting Flex Conduit</b>						
A	NO Double Rail						
B	12 in.						
C	16 in.						
D	20 in.						
E	24 in.						
F	32 in.						
G	40 in.						
H	52 in.						

<sup>1)</sup> Two wiring rails connected by flex conduit.

Conversion: 1 inch = 25,4 mm / 1 foot = 0,3 m

# Gas Engine Control Systems

## 2 Bracket Configuration

P/N <sup>1)</sup>	Figure	Description
75.10.303	2A	Bracket, 40x40 mm (Standard)
75.10.097	2B	Flat bar, 180° (Standard)
75.10.120	2C	Flat bar, 150°
75.10.280	2D	Flat bar, 90°

<sup>1)</sup> For packs of ten please add suffix „-10“ to part number.

## 3 Thermocouples with Lead and Wiring Rail Connector – 90° (1 per Cylinder required)

P/N	Figure	Description	Wiring Rail Connector	Length
56.01.090-10	3A	Thermocouple, Type K (NiCrNi)	MIL, 3 pole, pin, 180°, bay.	10 in.
56.01.090-20	3A	Thermocouple, Type K (NiCrNi)	MIL, 3 pole, pin, 180°, bay.	20 in.
56.01.090-25	3A	Thermocouple, Type K (NiCrNi)	MIL, 3 pole, pin, 180°, bay.	25 in.
56.01.090-30	3A	Thermocouple, Type K (NiCrNi)	MIL, 3 pole, pin, 180°, bay.	30 in.
56.01.090-40	3A	Thermocouple, Type K (NiCrNi)	MIL, 3 pole, pin, 180°, bay.	40 in.
56.01.090-60	3A	Thermocouple, Type K (NiCrNi)	MIL, 3 pole, pin, 180°, bay.	60 in.
56.01.090-K <sup>1)</sup>	3A	Thermocouple, Type K (NiCrNi)	MIL, 3 pole, pin, 180°, bay.	177 in.

<sup>1)</sup> Comes with loose connector and 177 in. lead length.

## 3 Thermocouples with Lead and Wiring Rail Connector – 180° (1 per Cylinder required)

P/N	Figure	Description	Wiring Rail Connector	Length
56.01.180-10	3B	Thermocouple, Type K (NiCrNi)	MIL, 3 pole, pin, 180°, bay.	10 in.
56.01.180-20	3B	Thermocouple, Type K (NiCrNi)	MIL, 3 pole, pin, 180°, bay.	20 in.
56.01.180-25	3B	Thermocouple, Type K (NiCrNi)	MIL, 3 pole, pin, 180°, bay.	25 in.
56.01.180-30	3B	Thermocouple, Type K (NiCrNi)	MIL, 3 pole, pin, 180°, bay.	30 in.
56.01.180-40	3B	Thermocouple, Type K (NiCrNi)	MIL, 3 pole, pin, 180°, bay.	40 in.
56.01.180-60	3B	Thermocouple, Type K (NiCrNi)	MIL, 3 pole, pin, 180°, bay.	60 in.
56.01.180-K <sup>1)</sup>	3B	Thermocouple, Type K (NiCrNi)	MIL, 3 pole, pin, 180°, bay.	177 in.

<sup>1)</sup> Comes with loose connector and 177 in. lead length.



2A



2B



2C



2D

# Gas Engine Control Systems

## 4 Harnesses to connect Wiring Rails with up to 8 Thermocouples (1 per Rail required)

P/N	Description	Wiring Rail Connector	Length
77.42.317-L	Harness for wiring rails	MIL, 17 pole, pin, 90°	„L“= 5/15/25/50 ft.

## 4 Harnesses to connect Wiring Rails with more than 8 Thermocouples (1 per Rail required)

P/N	Description	Wiring Rail Connector	Length
77.42.327-L	Harness for wiring rails	MIL, 17/10 pole, pin, 90°	„L“= 5/15/25/50 ft.

## 5 Accessories

P/N	Figure	Description
06.05.076	5	Junction box
76.70.007		MIL connector, 3 pole, pin, 180°, bay., for connection of already installed thermocouples to AlphaRail wiring rail
28.10.014		Cable, 2x1.5 mm <sup>2</sup> , type K (NiCrNi) <sup>1)</sup>

<sup>1)</sup> Cable needs to be ordered in m/ft. in required quantity.

## 6 TempScan20 Temperature Module

P/N	Figure	Description
63.03.002-20	6	TempScan20 temperature module, including connector package for power supply, CAN Bus and thermocouple wiring, operating manual
63.03.012-20		TempScan20 temperature module, built into stainless steel enclosure, including connector package for power supply, CAN Bus and thermocouple wiring, operating manual

## 7 PowerView3 HMI Modules & Activation Codes

P/N	Figure	Description
06.05.085	7	PowerView3 HMI module
06.05.185		PowerView3 HMI module, built into stainless steel enclosure
06.05.088-F		PowerView3 activation code for visualization of TempScan data – Activation code has to be ordered separately with each PowerView3 HMI module
06.05.088-U		PowerView3 activation code for visualization of TempScan data – Only available for upgrade of existing PowerView3 HMI module in the field



3A

3B

5

6

7



# Gas Engine Control Systems



MOTORTECH INTEGRATED THROTTLE BODY

## Throttle Bodies with Integrated Stepper Motor

- For naturally aspirated and turbocharged engines
- For use with natural gas, biogas (minor H<sub>2</sub>S content), mine gas, etc.
- Available as Series 50, 100, 140, 200
- Butterfly diameter 42-115 mm (1.65-4.53 in.), other dimensions available on request
- Rigid design
- High resolution stepper motor
- Applicable for temperatures up to 257 °F/125 °C, high temperature types (-HT) up to 392 °F/200 °C
- Controlled by MOTORTECH **VariStep3** stepper motor driver

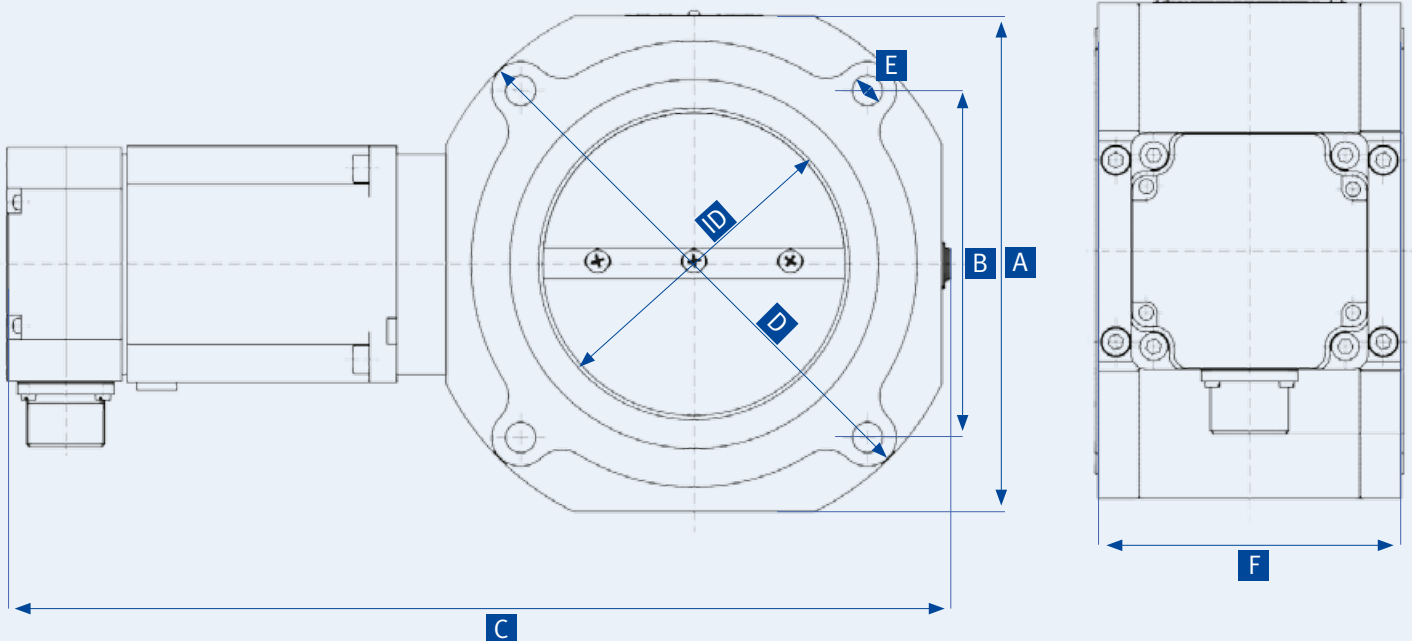
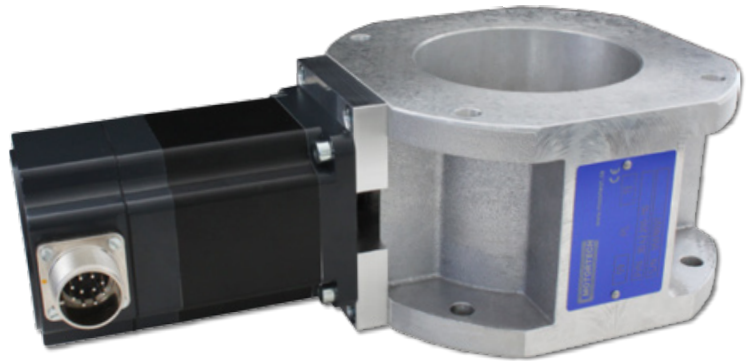

## Standard – Series 50 (Inner Diameter 41 to 42 mm)

P/N	Description	ID	A	B	C	D	E	F
30.42.050-42	Integrated throttle body	42 mm	88 mm	57 mm	245 mm	96 mm	8 mm	56 mm
30.42.050-42-HT	Integrated throttle body	42 mm	88 mm	57 mm	270 mm	96 mm	8 mm	56 mm

## Standard – Series 100 (Inner Diameter 48 to 68 mm)

P/N	Description	ID	A	B	C	D	E	F
30.42.100-60	Integrated throttle body	60 mm	113 mm	75 mm	270 mm	130 mm	11 mm	61 mm
30.42.100-60-HT	Integrated throttle body	60 mm	113 mm	75 mm	295 mm	130 mm	11 mm	61 mm
30.42.100-68	Integrated throttle body	68 mm	113 mm	75 mm	270 mm	130 mm	11 mm	61 mm
30.42.100-68-HT	Integrated throttle body	68 mm	113 mm	75 mm	295 mm	130 mm	11 mm	61 mm

## Standard – Series 140 (Inner Diameter 73 to 85 mm)

P/N	Description	ID	A	B	C	D	E	F
30.42.140-75	Integrated throttle body	75 mm	150 mm	95 mm	307 mm	166 mm	11 mm	76 mm
30.42.140-75-HT	Integrated throttle body	75 mm	150 mm	95 mm	332 mm	166 mm	11 mm	76 mm
30.42.140-80	Integrated throttle body	80 mm	150 mm	95 mm	307 mm	166 mm	11 mm	76 mm
30.42.140-80-HT	Integrated throttle body	80 mm	150 mm	95 mm	332 mm	166 mm	11 mm	76 mm
30.42.140-85	Integrated throttle body	85 mm	150 mm	95 mm	307 mm	166 mm	11 mm	76 mm
30.42.140-85-HT	Integrated throttle body	85 mm	150 mm	95 mm	332 mm	166 mm	11 mm	76 mm

## Standard – Series 150 (Inner Diameter 82 to 104 mm)

P/N	Description	ID	A	B	C	D	E	F
30.42.150-100	Integrated throttle body	100 mm	150 mm	110 mm	310 mm	196 mm	9 mm	86 mm
30.42.150-100-HT	Integrated throttle body	100 mm	150 mm	110 mm	348 mm	196 mm	9 mm	86 mm

## Standard – Series 200 (Inner Diameter 98 to 125 mm)

P/N	Description	ID	A	B	C	D	E	F
30.42.200-100	Integrated throttle body	100 mm	180 mm	126 mm	342 mm	200 mm	11 mm	110 mm
30.42.200-100-HT	Integrated throttle body	100 mm	180 mm	126 mm	381 mm	200 mm	11 mm	110 mm
30.42.200-105	Integrated throttle body	105 mm	180 mm	126 mm	342 mm	200 mm	11 mm	110 mm
30.42.200-105-HT	Integrated throttle body	105 mm	180 mm	126 mm	381 mm	200 mm	11 mm	110 mm
30.42.200-115	Integrated throttle body	115 mm	180 mm	126 mm	342 mm	200 mm	11 mm	110 mm
30.42.200-115-HT	Integrated throttle body	115 mm	180 mm	126 mm	381 mm	200 mm	11 mm	110 mm

## Stepper Motor Harness

P/N	Description	Connector	Length
31.01.942	Stepper motor harness	MIL, 10 pole, socket , 90°	10 m (400 in.)

## VariStep3 Stepper Motor Driver

P/N	Supersedes	Description
31.01.960	31.01.955	VariStep3 stepper motor driver

## Speed Control Kit incl. VariStep3 Stepper Motor Driver and SC100 Speed Controller

P/N	Supersedes	Description
63.04.002		Speed control kit incl. VariStep3 stepper motor driver and SC100 speed controller

# Gas Engine Control Systems



## Throttle Bodies

Various throttle bodies are available. All moving parts are made of stainless steel to survive in the harshest environments including H<sub>2</sub>S.

- For naturally aspirated and turbocharged engines
- Flange gaskets, lever, end stop and idle speed adjustment included
- Stainless steel ball bearings
- Other sizes and custom made designs on request.
- Applicable for temperatures up to 284 °F/140 °C, high temperature types (-HT) up to 392 °F/200 °C

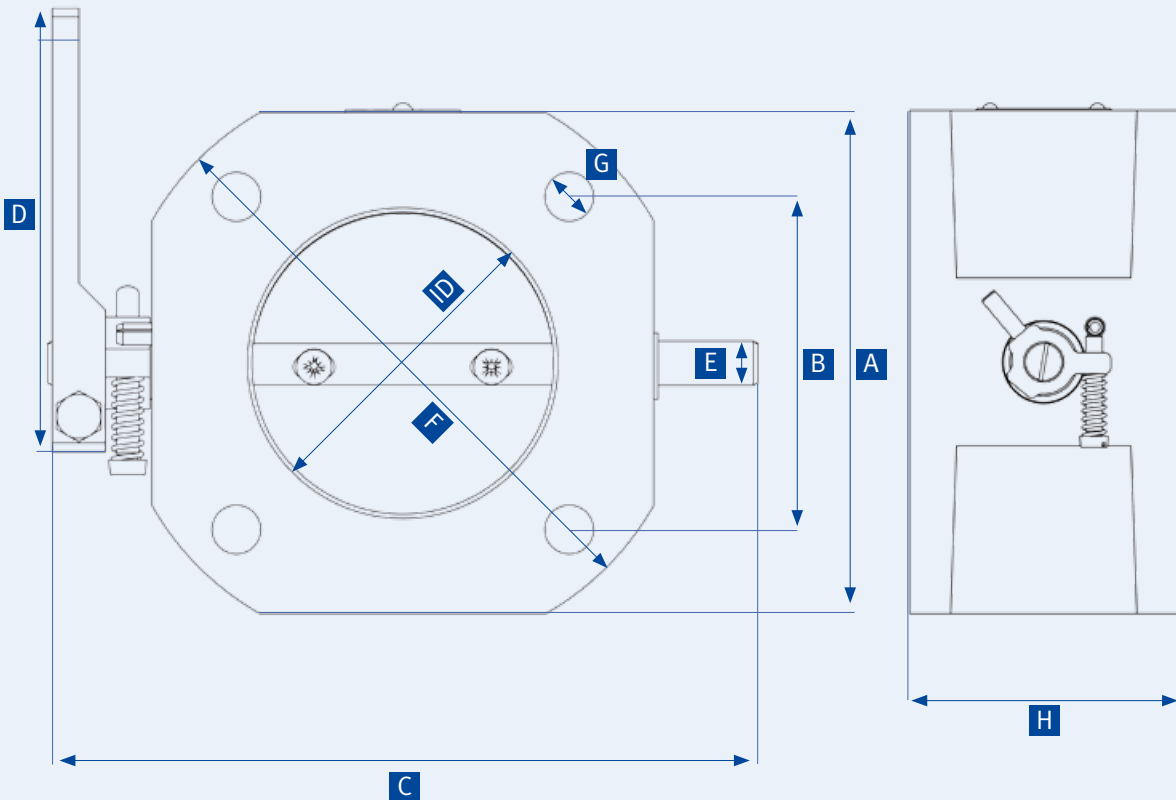
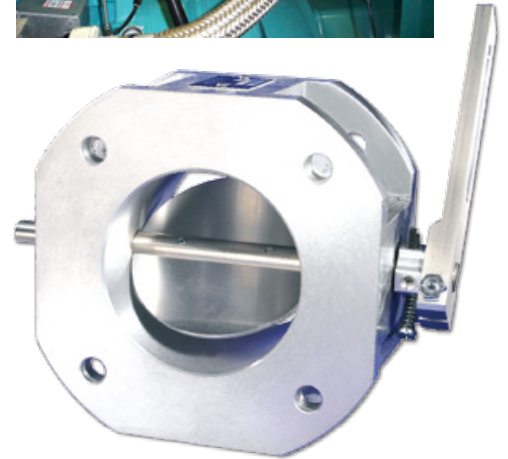
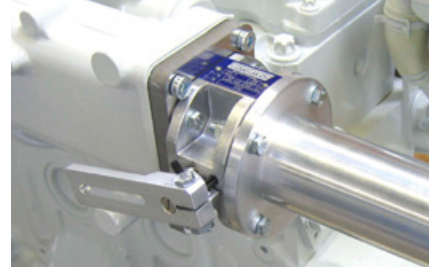

## Standard – Series 50 (Inner Diameter 41 to 42 mm)

P/N	Supersedes	Description	ID	A	B	C	D	E	F	G	H	Equivalent to
30.40.051-42	30.40.050-42	Throttle body	42 mm	88 mm	57 mm	135 mm	100 mm	10 mm	96 mm	8 mm	40 mm	451-00-042-00
30.40.051-42-HT		Throttle body	42 mm	88 mm	57 mm	135 mm	100 mm	10 mm	96 mm	8 mm	40 mm	

## Standard – Series 100 (Inner Diameter 48 to 68 mm)

P/N	Supersedes	Description	ID	A	B	C	D	E	F	G	H	Equivalent to
30.40.101-60	30.40.100-60	Throttle body	60 mm	113 mm	75 mm	160 mm	100 mm	10 mm	130 mm	11 mm	61 mm	
30.40.101-60-HT		Throttle body	60 mm	113 mm	75 mm	160 mm	100 mm	10 mm	130 mm	11 mm	61 mm	
30.40.101-68	30.40.100-68	Throttle body	68 mm	113 mm	75 mm	160 mm	100 mm	10 mm	130 mm	11 mm	61 mm	452-00-068-00
30.40.101-68-HT		Throttle body	68 mm	113 mm	75 mm	160 mm	100 mm	10 mm	130 mm	11 mm	61 mm	

## Standard – Series 140 (Inner Diameter 73 to 85 mm)

P/N	Supersedes	Description	ID	A	B	C	D	E	F	G	H	Equivalent to
30.40.141-75	30.40.140-75	Throttle body	75 mm	150 mm	95 mm	200 mm	150 mm	12 mm	166 mm	11 mm	76 mm	
30.40.141-75-HT		Throttle body	75 mm	150 mm	95 mm	200 mm	150 mm	12 mm	166 mm	11 mm	76 mm	
30.40.141-80	30.40.140-80	Throttle body	80 mm	150 mm	95 mm	200 mm	150 mm	12 mm	166 mm	11 mm	76 mm	
30.40.141-80-HT		Throttle body	80 mm	150 mm	95 mm	200 mm	150 mm	12 mm	166 mm	11 mm	76 mm	
30.40.141-85	30.40.140-85	Throttle body	85 mm	150 mm	95 mm	200 mm	150 mm	12 mm	166 mm	11 mm	76 mm	453-00-085-01
30.40.141-85-HT		Throttle body	85 mm	150 mm	95 mm	200 mm	150 mm	12 mm	166 mm	11 mm	76 mm	

## Standard – Series 150 (Inner Diameter 82 to 104 mm)

P/N	Supersedes	Description	ID	A	B	C	D	E	F	G	H	Equivalent to
30.40.151-100	30.40.150-100	Throttle body	100 mm	150 mm	110 mm	200 mm	150 mm	12 mm	196 mm	9 mm	80 mm	
30.40.151-100-HT		Throttle body	100 mm	150 mm	110 mm	200 mm	150 mm	12 mm	196 mm	9 mm	80 mm	

## Standard – Series 200 (Inner Diameter 98 to 125 mm)

P/N	Supersedes	Description	ID	A	B	C	D	E	F	G	H	Equivalent to
30.40.201-100	30.40.200-100	Throttle body	100 mm	180 mm	126 mm	260 mm	150 mm	12 mm	200 mm	11 mm	110 mm	
30.40.201-100-HT		Throttle body	100 mm	180 mm	126 mm	260 mm	150 mm	12 mm	200 mm	11 mm	110 mm	
30.40.201-105	30.40.200-105	Throttle body	105 mm	180 mm	126 mm	260 mm	150 mm	12 mm	200 mm	11 mm	110 mm	
30.40.201-105-HT		Throttle body	105 mm	180 mm	126 mm	260 mm	150 mm	12 mm	200 mm	11 mm	110 mm	
30.40.201-115	30.40.200-115	Throttle body	115 mm	180 mm	126 mm	260 mm	150 mm	12 mm	200 mm	11 mm	110 mm	454-00-115-00
30.40.201-115-HT		Throttle body	115 mm	180 mm	126 mm	260 mm	150 mm	12 mm	200 mm	11 mm	110 mm	

## Special – Series 100/140 – IMPCO® Replacements <sup>1)</sup>

P/N	Supersedes	Description	ID	Equivalent to
30.40.101-68AT2-7		Throttle body	68 mm	AT2-7
30.40.141-94AT2-9		Throttle body	94 mm	AT2-9

<sup>1)</sup> Common applications e.g. CATERPILLAR® G379, G3306, G3406, WAUKESHA® F1197

## Special – Series 160 – For CATERPILLAR® G3400 & G3500 Series Gas Engines

P/N	Supersedes	Description	ID	Equivalent to
30.40.161-106		Throttle body	106 mm	7E-1585, 7E-1589

# Gas Engine Control Systems

## Throttle Bodies for MAN® E2876 LE 202/212/302

Based on its proven design, MOTORTECH offers a special throttle body for MAN® engine series E2876 LE. Engineered as a replacement and plug & play solution for the original part, the throttle body perfectly fits into the existing structure between both manifolds behind the intercooler of the engine.

In addition to the commonly used version, MOTORTECH completes the series with the ITB throttle body design. The integrated stepper motor is extremely precisely actuated by the VariStep3 stepper motor driver in combination with the SC100 speed controller and eliminates the use of an external actuator. This version is especially suited for new installations or plant and engine revisions.



### Properties & Features

- Applicable for media such as natural gas and special gases
- Reinforced shaft and butterfly valve made of stainless
- High temperature resistant shaft seals
- Use of ball bearings instead of plain bearings
- End stop and screw for idle speed adjustment
- Lever for connection to the external actuator or integrated stepper motor
- Same flange design for a simple replacement
- O-rings for sealing embedded in the housing
- Maintenance-free part

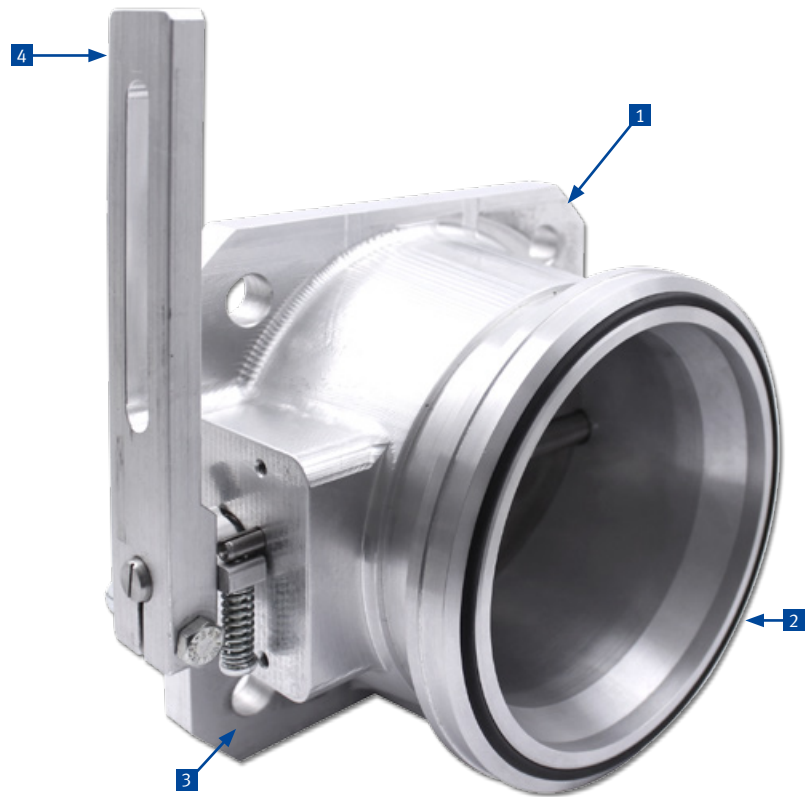

Flange opposite to intercooler



Flange intercooler-sided

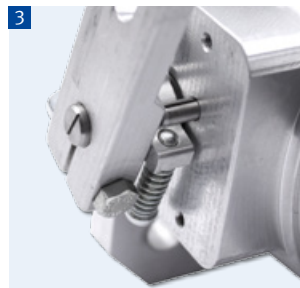

End stop and screw for idle speed adjustment



Lever for connection to an external actuator



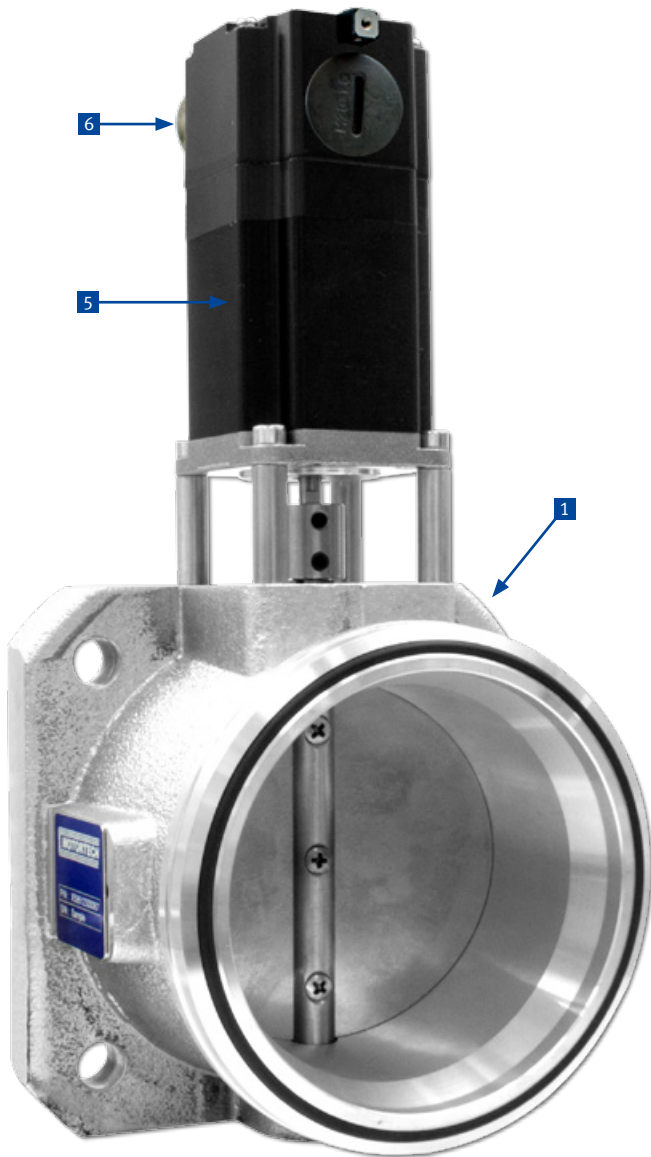

Integrated stepper motor



MIL connector for connection to VariStep3 stepper motor driver



VariStep3 stepper motor driver



SC100 speed controller

Gas Engine Control Systems

## Throttle Body

P/N	Supersedes	Description	Equivalent to
30.41.152-100-HT		Throttle body for MAN® E2876 LE 2xx/302	51.13105-6013, 51.13105-6021

## ITB Throttle Body & Accessories

P/N	Figure	Supersedes	Description	Equivalent to
30.43.152-100			ITB throttle body for MAN® E2876 LE 2xx/302	51.13105-6013, 51.13105-6021
31.01.942	7		Stepper motor harness, MIL,10 pole, socket, 90°, length 10 m (400 in.)	
31.01.960			VariStep3 stepper motor driver	
63.50.114	8		SC100 speed controller	
63.60.001-50			Pickup, magnetic, M16x1,5 x 64 mm, 50 ft./15 m cable	
alternative 63.60.002-50			Pickup, magnetic, 5/8-18 UNF x 64 mm, 50 ft./15 m cable	

# Gas Engine Control Systems

## Throttle Bodies for WAUKESHA® VHP G/ GSI/ LT 6 and 12 Cylinder Engines

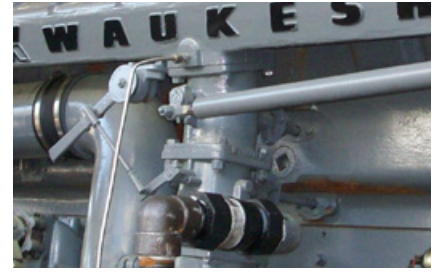

Based on its proven design, MOTORTECH offers a special throttle body series for WAUKESHA® VHP series in-line and V-engines. Designed as a replacement and plug-and-play solution, the throttle bodies perfectly fit the position of the original part below the intake manifold.

In addition and as an upgrade to the commonly used version, MOTORTECH completes the series with the ITB throttle body design. The integrated stepper motor is extremely precisely actuated by the VariStep3 stepper motor driver and eliminates the use of an external actuator. Both, ITB throttle body and VariStep3 stepper motor driver, operate with the standard WOODWARD® 2301D speed governor or with the MOTORTECH SC100 speed controller.

### Properties & Features

- Same design and shape for easy replacement of original part
- Reinforced shaft and butterfly valve made of stainless for high durability even when backfiring has occurred
- Use of ball bearings instead of plain bearings
- Including end stop and idle speed adjustment
- Lever for connection to the external actuator or integrated stepper motor
- High temperature resistant shaft seals
- Usable with natural and special gases
- Maintenance free product

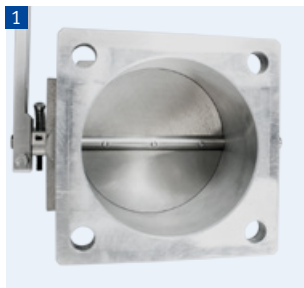
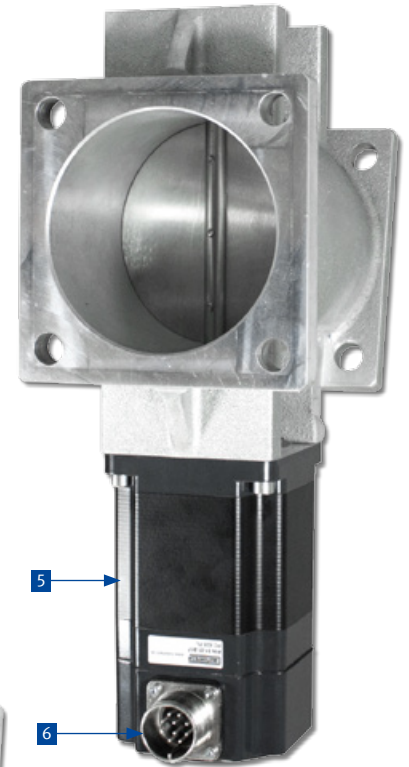
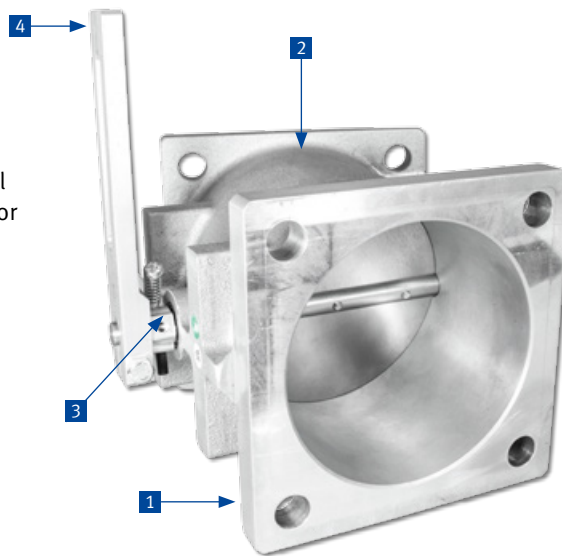

Same flange sizes as original part



Identical design and shape for easy assembly



End stop with adjustment screw for idle speed



Lever for connection to the external actuator





Integrated stepper motor



MIL style connector for connection to VariStep3 stepper motor driver



VariStep3 stepper motor driver



SC100 speed controller

## Throttle Bodies

P/N	Description	Equivalent to
30.41.151-106-VHP-6	Throttle body for WAUKESHA® VHP 6 cylinder in-line engines F2895G/GSI, F3521G/GSI	E204072
30.41.151-106-VHP-12	Throttle body for WAUKESHA® VHP 12 cylinder V-engines L5108G/GSI, L5790G/GSI, L5774LT, L5794GSI, L7042G/GSI, L7044GSI, fits left and right bank	E204072, A204072, E204072A, A204072A, F204072A

## ITB Throttle Bodies & Accessories

P/N	Description	Quantity	Equivalent to
75.30.148-6	ITB throttle body conversion kit for WAUKESHA® VHP 6 cylinder in-line engines F2895G/GSI, F3521G/GSI <i>Contains:</i> – ITB throttle body P/N 30.43.151-106-VHP-6 – Stepper motor harness P/N 31.01.942 – VariStep3 stepper motor driver P/N 31.01.960 <b>7</b>	– 1 pc. – 1 pc. – 1 pc.	– E204072
alternative 75.30.149-6	ITB throttle body conversion kit for WAUKESHA® VHP 6 cylinder in-line engines F2895G/GSI, F3521G/GSI <i>Contains:</i> – ITB throttle body P/N 30.43.151-106-VHP-6 – Stepper motor harness P/N 31.01.942 – VariStep3 stepper motor driver P/N 31.01.960 <b>7</b> Stepper motor driver built into stainless steel enclosure	– 1 pc. – 1 pc. – 1 pc.	– E204072
75.30.148-12	ITB throttle body conversion kit for WAUKESHA® VHP 12 cylinder V-engines L5108G/GSI, L5790G/GSI, L5774LT, L5794GSI, L7042G/GSI, L7044GSI <i>Contains:</i> – ITB throttle body P/N 30.43.151-106-VHP-12, fits left and right bank – Stepper motor harness P/N 31.01.942 – VariStep3 stepper motor driver P/N 31.01.960 <b>7</b> – Isolation amplifier P/N 63.02.017	– 2 pc. – 2 pc. – 2 pc. – 1 pc.	– E204072, A204072, E204072A, A204072A, F204072A
alternative 75.30.149-12	ITB throttle body conversion kit for WAUKESHA® VHP 12 cylinder V-engines L5108G/GSI, L5790G/GSI, L5774LT, L5794GSI, L7042G/GSI, L7044GSI <i>Contains:</i> – ITB throttle body P/N 30.43.151-106-VHP-12, fits left and right bank – Stepper motor harness P/N 31.01.942 – VariStep3 stepper motor driver P/N 31.01.960 <b>7</b> – Isolation amplifier P/N 63.02.017 Stepper motor drivers and isolation amplifier pre wired and built into stainless steel enclosure	– 2 pc. – 2 pc. – 2 pc. – 1 pc.	– E204072, A204072, E204072A, A204072A, F204072A
optional 63.50.114	SC100 speed controller <b>8</b> to replace WOODWARD® 2301D speed governor	– 1 pc. per kit	

# Gas Engine Control Systems

## ALL-IN-ONE MOTORTECH GENERATOR & CHP CONTROL SYSTEM

For monitoring, controlling, regulating and system protection.

ALL-IN-ONE is an expandable controller for both single and multiple gen-sets operating in standby or parallel modes, especially in cogeneration (CHP) and other complex applications.

Modular design (consisting of AIO controller and display unit) allows easy installation with the ability to add many different extension modules designed to suit individual customer requirements.

Built-in synchronizing, digital isochronous load sharing and Air/Fuel Ratio functions (requires additional dongle) allow a total integrated solution for gen-sets in standby, island, parallel or mains parallel. Native co-operation of up to 32 gen-sets is a standard feature.

AIO supports many standard ECU (electronic control unit) types and is specially designed to easily integrate new ones.

A powerful graphic display with user-friendly controls allows any user whatever their ability to find the information they need. The display on the basic version is capable of displaying graphical languages (e.g. Chinese).



### Benefits

- Support of engines with ECU (Electronic control unit)
- Excellent configurability to match customer's needs exactly
- Complete integrated gen-set solution incorporating built-in PLC and signal sharing via CAN bus – minimum external components needed
- Many communication options – easy remote supervising and servicing
- Perfect price / performance ratio
- Gen-set performance log for easy problem tracing
- Air/Fuel Ratio function for lean burn gas engine (requires additional hardware dongle)

### Features

- CHP support (programmable PID loops and other built-in PLC functions)
- Support of engines with ECU (J1939, Modbus and other proprietary interfaces); alarm codes displayed in text form
- Automatic synchronizing and power control (via speed governor or ECU)
- Baseload, Import/Export, TempByPower
- Peak shaving

- Voltage and PF control (AVR)
- Generator measurement: U, I, Hz, kW, kVAr, kVA, PF, kWh, kVAhr
- Mains measurement: U, I, Hz, kW, kVAr, PF
- Selectable measurement ranges for AC voltages and currents – 120/277 V, 0–1/0–5 A
- Inputs and outputs configurable for various customer needs
- Controller redundancy
- 2× RS232/RS485 interface with Modbus protocol
- Support; Analog/GSM/ISDN/CDMA modem communication support; SMS messages; ECU Modbus interface; secondary RS485 converter is isolated
- Event-based history (up to 1000 records) with customer-selectable list of stored values; RTC; statistic values
- Integrated PLC programmable functions
- Interface to remote display units (3× AIO.Vision-display)
- USB 2.0 slave interface
- Dimensions 284×180 mm (front panel)
- Sealed to IP65

### Integrated fixed and configurable protections

- 3 phase integrated generator protections (U + f)
- IDMT overcurrent + shortcurrent protection
- Overload protection
- Reverse power protection
- Earth fault protection
- 3 phase integrated mains protections (U + f)
- Vector shift protection
- All binary/analog inputs free configurable for various protection types: HistRecOnly/ Alarm Only/Alarm + History indication/Warning/ Off load/Slow stop/BreakerOpen&Cooldown/ Shutdown/Shutdown override/Mains protect/ sensor fail
- Phase rotation and phase sequence protection
- Additional 160 programmable protections configurable for any measured value to create customer-specific protections
- Application security

# Gas Engine Control Systems



## InteliMains

- Import/Export
- Load Sharing
- Power Plant Management
- Grid Monitoring
- Running Hours Optimization

## InteliPro

- Designed to meet utility protection requirements
- Combines standard and optional features
- Advanced communications
- Data/event logging

or

## MainsPro

- Protective functionalities
- Free assignment of 5 relay outputs
- 4 binary switches to remotely change operation of the unit
- Last trip recorded in order to provide the evidence of cause of trip

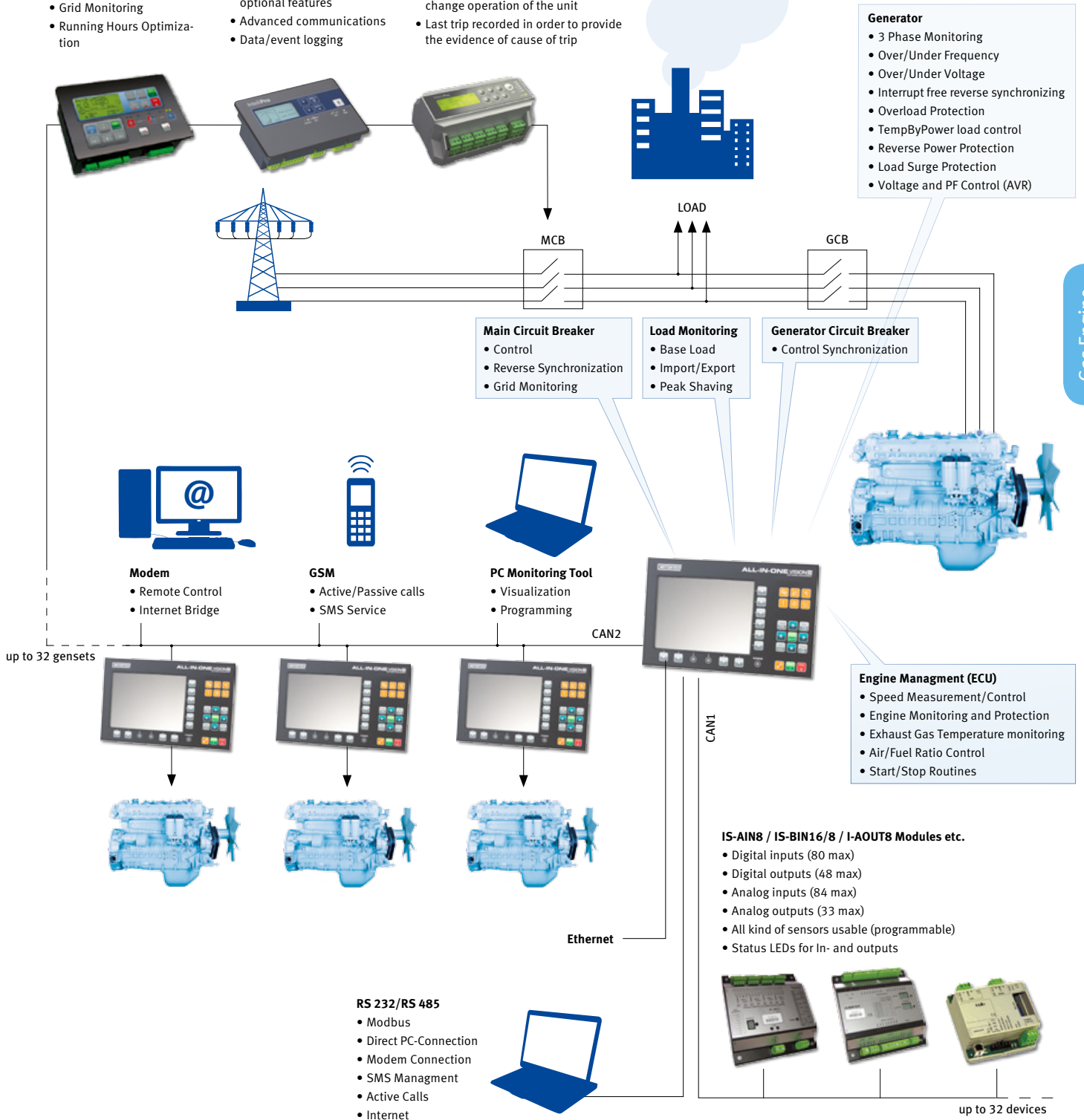

# Gas Engine Control Systems

## Controllers

P/N	Supersedes	Description
63.50.104		ALL-IN-ONE.NTC controller – universal gen-set controller (incl. AFR control <sup>1)</sup> and AirGate® technology)
63.50.104-HSS		ALL-IN-ONE.NTC controller – universal gen-set controller P/N 63.50.104 incl. Plug-on module I-HSS-BIN6/10
63.50.096		ALL-IN-ONE.GAS controller – universal gen-set controller (incl. AFR control <sup>2)</sup> and AirGate® technology)
63.50.082		Mini-ALL-IN-ONE controller – universal controller for small gen-sets (incl. AFR control <sup>3)</sup> )

<sup>1)</sup> Requires hardware dongle P/N 63.50.061 or 63.50.062 for activation. <sup>2)</sup> Requires hardware dongle for activation. Consult factory for availability.

<sup>3)</sup> Requires hardware dongle P/N 63.50.085 for activation (for applications up to 75 kWel only).

## Display Units for ALL-IN-ONE.NTC/.GAS Controllers

P/N	Supersedes	Description
63.50.105		ALL-IN-ONE.Vision5 display – 5.7 in. color display unit for ALL-IN-ONE.NTC and ALL-IN-ONE.GAS controller
63.50.101		ALL-IN-ONE.Vision8 display – 8.0 in. color display unit for ALL-IN-ONE.NTC and ALL-IN-ONE.GAS controller
63.50.097		ALL-IN-ONE.Vision12 display – 12.0 in. color touch display unit for ALL-IN-ONE.NTC and ALL-IN-ONE.GAS controller
63.50.120	63.50.115	ALL-IN-ONE.Vision17 display – 17.0 in. color touch display unit for ALL-IN-ONE.NTC and ALL-IN-ONE.GAS controller

## Dongles

P/N	Supersedes	Description
63.50.061		Hardware dongle for ALL-IN-ONE.NT/.NTC controllers – AFR-PCM <ul style="list-style-type: none"> <li>• Enables single isolated parallel with mains</li> <li>• Air/Fuel Ratio function for lean burn gas engines</li> </ul>
63.50.062		Hardware dongle for ALL-IN-ONE.NT/.NTC controllers – AFR-PCLSM+PMS <ul style="list-style-type: none"> <li>• Enables multiple isolated parallel or multiple parallel with mains</li> <li>• Power management operation (with CAN Bus)</li> <li>• Digital load sharing</li> <li>• Digital VAR sharing</li> <li>• Optimizing number of running engines: Power management; kW, kVA or % load based</li> <li>• Air/Fuel Ratio function for lean burn gas engines</li> </ul>
63.50.085		Hardware dongle for Mini-ALL-IN-ONE – miniAFR-PCM <ul style="list-style-type: none"> <li>• Enables single isolated parallel with mains</li> <li>• Air/Fuel Ratio function for lean burn gas engines</li> <li>• For applications up to 75 kWel only</li> </ul>



## AIO Controllers

AIO.GAS Controller  
P/N 63.50.096

AIO.NTC Controller  
P/N 63.50.104

Mini-AIO Controller  
P/N 63.50.082



## Available Display Units for AIO.NTC and AIO.GAS Controllers



AIO.Vision 17  
P/N 63.50.120



AIO.Vision 12  
P/N 63.50.097



AIO.Vision 8  
P/N 63.50.101



AIO.Vision 5  
P/N 63.50.105

## Other Controllers

P/N	Supersedes	Description
63.50.064		Mains supervision controller – IM-NT
63.50.064-BTB		Mains supervision controller Bus Tie Breaker – IM-NT BTB
63.50.064-MCB		Mains supervision controller Main Circuit Breaker – IM-NT MCB

## Accessories

P/N	Supersedes	Description
63.50.092		Analog input extension module – I-AIN8
63.50.002		Analog input extension module – IS-AIN8
63.50.093		Analog input extension module for thermocouples only – I-AIN8TC
63.50.118		Extension module inputs/outputs – IO8/8
63.50.005		Binary input/output module, 16 inputs, 8 outputs – IS-BIN16/8
63.50.007		Analog/binary input/output module – IGS-PTM
63.50.007-HSS		Analog/binary input/output module P/N 63.50.007 incl. plug-on module I-HSS-BIN8
63.50.011		AVR interface module – IG-AVRi
63.50.010-100		Power supply transformer for IG-AVRi module, 100-120 VAC, 50-60 Hz
63.50.010-230		Power supply transformer for IG-AVRi module, 230-480 VAC, 50-60 Hz
63.50.054		Analog output module – I-AOUT8
63.50.075	63.50.006	Modem extension unit – I-LB+
63.50.112	63.50.022	Internet bridge communication module – IB-NT
63.50.088		CAN repeater module – I-CR





# Gas Engine Control Systems

## MOT-Actuator MOTORTECH ELECTRIC ESM EXT ACTUATOR

MOTORTECH Actuator Replacement Kit for WAUKESHA® VHP Series Four® with ESM and Extender® Series Engines

### Features

- Drop in replacement
- Eliminates HEINZMANN® actuator
- Works on WAUKESHA® VHP L5774LT, L5794GSI/LT and L7044GSI

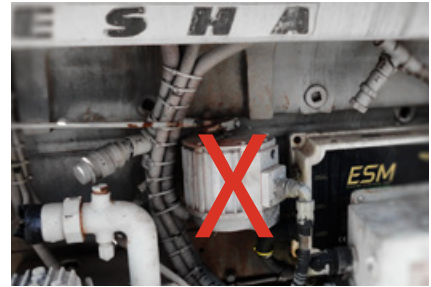

Replacement Kit for WAUKESHA® VHP Series Four® with ESM and Extender® Series Engines

P/N	Supersedes	Description	Equivalent to
63.04.176	63.50.175	Actuator replacement kit	214046



- Plug and play connection
- Does **not** require any
  - ▶ ESM software adjustment
  - ▶ or harness modification



- Mounting bracket, included
- Allows easy drop in installation



- Lever, included
- Simple connection to existing linkage

**INSTALLATION NOTICE:** If used on 6 cylinder WAUKESHA® VHP engines the IMPCO® throttle needs to be readjusted by flipping it over 180 degrees.





## ■ Sensor Systems

### Thermocouple Rails for WAUKESHA® 12 Cylinder VHP Engines

MOTORTECH offers a series of different Thermocouple Rail Upgrade Kits. The rails are installed in the “Vee” or on the side of the engine. These rail kits replace any prior system if installed.

- Direct replacement for WAUKESHA® Thermocouple Conduit Assembly
- Available in different versions
- Prefabricated system guarantees easy exchange and installation
- Serviceable stainless steel wiring rail, no foam inside
- 14 thermocouples, Type K (NiCrNi), 90°
- Harness with flex conduit and J-Box or a large connector to fit the ESM
- Rail mounting brackets included in each kit
- 3 Versions Available



Thermocouples, Type K, NiCrNi, 90°



Harness with flex conduit and fitting

### Thermocouple Wiring Rail Kit with 8 ft. Harness to Junction Box

*Contains:*

- 14 thermocouples, Type K (NiCrNi), 90°, equivalent to WAUKESHA® P/N 211288S
- 8.5 ft. harness with flex conduit and fitting
- Rail mounting bracket (2 sets)
- Junction box P/N 06.05.076 with 44 terminals



P/N	Description	Equivalent to
D211359G-MOT	Thermocouple wiring rail kit	D211359G

# Sensor Systems



## Thermocouple Wiring Rail Kit with 50 ft. Harness for Direct Wiring

*Contains:*

- 14 thermocouples, Type K (NiCrNi), 90°, equivalent to WAUKESHA® P/N 211288S, but 50 ft. cable length
- 50 ft. harness with flex conduit and fitting
- Rail mounting bracket (2 sets)

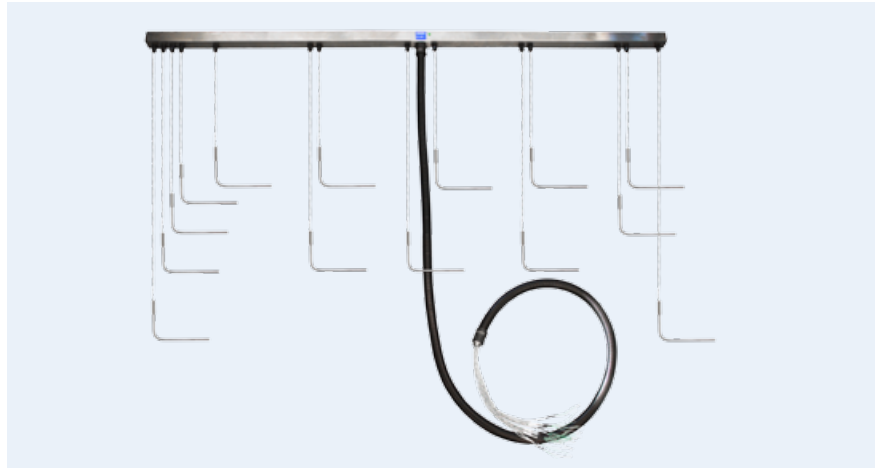

P/N	Description	Equivalent to
77.75.068-50	Thermocouple wiring rail kit	

## Thermocouple Wiring Rail Kit with 8 ft. Harness and Connector to ESM Wiring System

*Contains:*

- 14 thermocouples, Type K (NiCrNi), 90°, equivalent to WAUKESHA® P/N 211288S
- 8 ft. harness with flex conduit and 33 pole connector, socket
- Rail mounting bracket (2 sets)

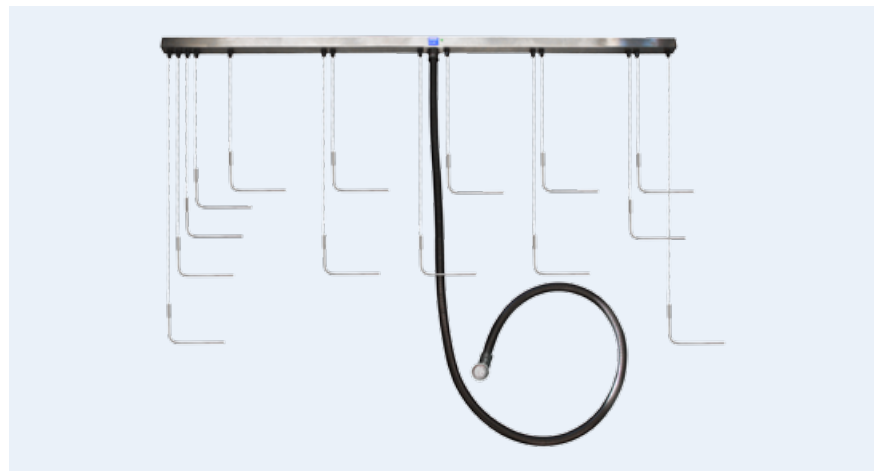

P/N	Description	Equivalent to
77.75.066	Thermocouple wiring rail kit	214036D

### Optional Parts

P/N	Description	Required Quantity	Equivalent to
64.40.038	Fitting, 1/4 in., outer thread 1/4 in. NPT	14 pcs. per rail kit	194929



### Spare Parts

P/N	Description	Lead Length	For use with	Equivalent to
56.01.094-23	Thermocouple, Type K (NiCrNi), 90°	23 ft.	D211359G-MOT, 77.75.066	211288S
56.01.094-59	Thermocouple, Type K (NiCrNi), 90°	59 ft.	77.75.068-50	



Sensor Systems

# Sensor Systems

## Thermocouples for CATERPILLAR® G3500/B/C/E & G3600 Series Gas Engines

P/N	Figure	Description	Connector	Length	Equivalent to
56.01.092-28	1	Thermocouple, Type K (NiCrNi), 90°	2 pole, pin, 180°	28.00 in.	383-2989, 241-9591, 175-5341, 6I-0407 <sup>1)</sup>
56.01.098-34	1	Thermocouple, Type K (NiCrNi), 90°	3 pole, pin, 180°	34.00 in.	152-0807

<sup>1)</sup> If the MOTORTECH thermocouple is used to replace thermocouple 175-5341 or 6I-0407, the engine wiring harness must be modified by replacing the bullet connector with kit P/N 75.30.046. Please order separately with each thermocouple.

## Connector Kit for Thermocouples

P/N	Description	Equivalent to
75.30.046	Connector kit incl. housing, contacts and wedge lock	

## Thermocouple for CUMMINS® QSK60G and QSV81/91G – For use with AlphaRail Wiring Rail System for Temperature Control

P/N <sup>1)</sup>	Description	Wiring Rail Connector	Length	Equivalent to
56.01.091-25	Thermocouple, Type K (NiCrNi), 90°	MIL, 3 pole, pin, 180°, bay.	25.00 in.	

<sup>1)</sup> Other lengths available on request.

## Thermocouple and Connecting Cable for MAN® E08, E26, E28 & E32 Series Gas Engines

P/N	Figure	Description	Connector	Length	Equivalent to
51.27421-0158-MOT	2	Thermocouple, Type K (NiCrNi), 90°	4 pole, socket, 180°	14.00 in.	51.27421-0158
06.30.112		Connecting cable for thermocouple	4 pole, pin, 180°	210.00 in.	51.25411-6028

## Thermocouples for MWM®/DEUTZ® Gas Engines

P/N	Figure	Description	Engine Series
1229 6754	3	Thermocouple, Type K (NiCrNi)	TBG 616
1229 9487	3	Thermocouple, Type K (NiCrNi)	TBG 616, TCG 2016
1229 3602	3	Thermocouple, Type K (NiCrNi)	TBG 616, TBG 620
1232 3810	3	Thermocouple, Type K (NiCrNi)	TBG 616, TBG 620, TCG 2016, TCG 2020
1232 2279	3	Thermocouple, Type K (NiCrNi)	TCG 2016



## Thermocouples for WAUKESHA® AT25 and AT27 Series Gas Engines

P/N	Figure	Description	Wiring Rail Connector	Length	Equivalent to
56.01.005-42	4	Thermocouple, Type K (NiCrNi), 180°	3 pole socket, 180°	42.00 in.	295962
56.01.005-53	4	Thermocouple, Type K (NiCrNi), 180°	3 pole socket, 180°	53.00 in.	295962A
56.01.005-70	4	Thermocouple, Type K (NiCrNi), 180°	3 pole socket, 180°	70.00 in.	295962B
56.01.005-81	4	Thermocouple, Type K (NiCrNi), 180°	3 pole socket, 180°	81.00 in.	295962C

## AlphaRail MOTORTECH WIRING RAIL SYSTEM

### Thermocouples for use with AlphaRail Wiring Rail System for Temperature Control

P/N	Figure	Description	Wiring Rail Connector	Length	Equivalent to
56.01.090-10	5	Thermocouple, Type K (NiCrNi), 90°	MIL, 3 pole, pin, 180°, bay.	10.00 in.	
56.01.090-20	5	Thermocouple, Type K (NiCrNi), 90°	MIL, 3 pole, pin, 180°, bay.	20.00 in.	
56.01.090-25	5	Thermocouple, Type K (NiCrNi), 90°	MIL, 3 pole, pin, 180°, bay.	25.00 in.	
56.01.090-30	5	Thermocouple, Type K (NiCrNi), 90°	MIL, 3 pole, pin, 180°, bay.	30.00 in.	
56.01.090-40	5	Thermocouple, Type K (NiCrNi), 90°	MIL, 3 pole, pin, 180°, bay.	40.00 in.	
56.01.090-60	5	Thermocouple, Type K (NiCrNi), 90°	MIL, 3 pole, pin, 180°, bay.	60.00 in.	
56.01.090-K <sup>1)</sup>	5	Thermocouple, Type K (NiCrNi), 90°	MIL, 3 pole, pin, 180°, bay.	177.00 in.	
56.01.180-10	6	Thermocouple, Type K (NiCrNi), 180°	MIL, 3 pole, pin, 180°, bay.	10.00 in.	
56.01.180-20	6	Thermocouple, Type K (NiCrNi), 180°	MIL, 3 pole, pin, 180°, bay.	20.00 in.	
56.01.180-25	6	Thermocouple, Type K (NiCrNi), 180°	MIL, 3 pole, pin, 180°, bay.	25.00 in.	
56.01.180-30	6	Thermocouple, Type K (NiCrNi), 180°	MIL, 3 pole, pin, 180°, bay.	30.00 in.	
56.01.180-40	6	Thermocouple, Type K (NiCrNi), 180°	MIL, 3 pole, pin, 180°, bay.	40.00 in.	
56.01.180-60	6	Thermocouple, Type K (NiCrNi), 180°	MIL, 3 pole, pin, 180°, bay.	60.00 in.	
56.01.180-K <sup>1)</sup>	6	Thermocouple, Type K (NiCrNi), 180°	MIL, 3 pole, pin, 180°, bay.	177.00 in.	

<sup>1)</sup> Comes with loose connector and 177 in. lead length.



4



5



6

# Sensor Systems

## Sensors

For several years MOTORTECH offers oxygen sensors that can be used as replacements for the OEM part. Shielded and unshielded versions can be selected.



### Oxygen Sensors for CATERPILLAR® G3400 and G3500 Series Gas Engines

P/N	Figure	Description	Connector	Length	Equivalent to
19.60.027	1	Oxygen sensor, unshielded	MIL, 6 pole, pin, 180°	10.00 in.	196-5391
19.60.029	2	Oxygen sensor, shielded	MIL, 6 pole, pin, 180°	51.00 in.	141-2494

### Oxygen Sensor for WAUKESHA® VHP G/GSI/LT Series Gas Engines

P/N	Figure	Description	Connector	Length	Equivalent to
A740106E-MOT	3	Oxygen sensor	2 pole, pin, 180°	17.00 in.	A740106E, A740106D, A740106C

### Oxygen Sensor Harness for WAUKESHA® Gas Engines

P/N	Figure	Description	Connector	Length	Equivalent to
06.30.110		Oxygen sensor harness	9 pole, pin, 180°	90.00 in.	A740735

### UEGO Oxygen Sensor

P/N	Figure	Description	Connector	Length	Equivalent to
19.60.007	4	UEGO oxygen sensor	8 pole, pin, 180°	15.75 in.	DL08311001
19.71.013		UEGO oxygen sensor lead	8 pole, socket, 180°	79.00 in.	DL08311003



## Oxygen Sensor – Heated

P/N	Figure	Description	Connector	Length	Equivalent to
19.60.015	5	Oxygen sensor, heated	4 pole, pin, 180°	1.15 ft. (0.35 m)	
19.71.015-2		Oxygen sensor lead	4 pole, socket, 180°	6.50 ft. (2.00 m)	
19.71.015-3		Oxygen sensor lead	4 pole, socket, 180°	9.80 ft. (3.00 m)	
19.71.015-15		Oxygen sensor lead	4 pole, socket, 180°	49.00 ft. (15.00 m)	
19.71.015-30		Oxygen sensor lead	4 pole, socket, 180°	98.00 ft. (30.00 m)	

## Oxygen Sensor – Non Heated

P/N	Figure	Description	Connector	Length	Equivalent to
19.60.004	5	Oxygen sensor, non heated	2 pole, pin, 180°	1.15 ft. (0.35 m)	
19.71.004-32		Oxygen sensor lead	2 pole, socket, 180°	32.00 ft. (9.75 m)	
19.71.004-50		Oxygen sensor lead	2 pole, socket, 180°	50.00 ft. (15.00 m)	
19.71.004-100		Oxygen sensor lead	2 pole, socket, 180°	100.00 ft. (30.00 m)	

To increase life time of these critical sensors, there is also a stainless steel hub available that is welded into the exhaust pipe.

A heat shield can be screwed on top. This way the sensor does reach directly into the exhaust gas stream with all its deposits and the heat shield protects the sensor against transient temperature from the hot exhaust manifold.

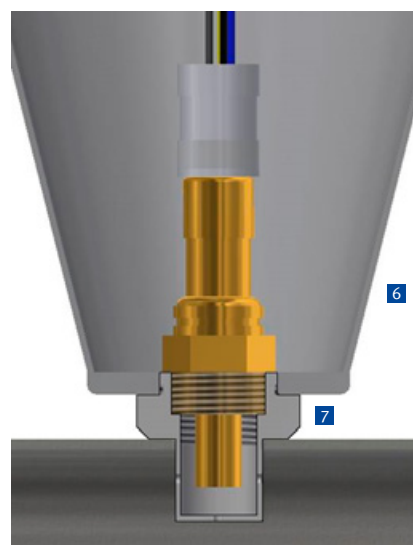

Sensor Systems

## Accessories for Oxygen Sensors

P/N	Figure	Description	Equivalent to
19.60.022	6	Heat shield	
19.60.023	7	Weld hub	



# Sensor Systems

## MAT – Manifold Air Temperature Sensors

P/N	Figure	Supersedes	Description	Thread	Fitting Length	Equivalent to
56.01.004	7	56.01.021	MAT sensor	G1/2 in.	2.00 in. (50 mm)	
56.01.011	7		MAT sensor	G1/2 in.	3.00 in. (75 mm)	
56.01.017	7		MAT sensor	G1/2 in.	4.00 in. (100 mm)	

## Temperature Sensor for MAN® E08 & E28 Series Gas Engines

P/N	Figure	Description	Thread	Fitting Length	Equivalent to
56.01.025	8	Temperature sensor with switch	M14x1.5	1.60 in. (40 mm)	51.27420-0008

## MAP – Manifold Absolute Pressure Sensor (Automotive Design)

P/N	Figure	Description	Connector	Length	Equivalent to
19.60.002	9	MAP sensor	3 pole, socket		6910-314
19.71.002		MAP sensor lead	3 pole, pin, 180°	26.00 ft. (8.00 m)	DL08220604

## MAP – Manifold Absolute Pressure Sensors (Industrial Design)

P/N	Figure	Supersedes	Description	Thread	Pressure Range	Equivalent to
56.01.001	10		MAP sensor	G1/4 in.	0 to 10.0 bar	
56.01.002	10		MAP sensor	G1/4 in.	0 to 6.0 bar	
56.01.010	10		MAP sensor	G1/4 in.	0 to 16.0 bar	
56.02.017	10	56.02.016	MAP sensor	G1/4 in.	0 to 3.0 bar	



7



8



9



10



## Sensor Harnesses for MAN® Gas Engines

P/N	Description	Engine Model	Equivalent to
06.30.024	Harness with all sensors	E0834 E302/312	
06.30.022	Connecting harness to PLC	E0834 E302/312	
06.30.101	Harness with all sensors	E0834 LE302	
06.30.102	Connecting harness to PLC	E0834 LE302	
06.30.023	Harness with all sensors	E0836 E302/312	
06.30.022	Connecting harness to PLC	E0836 E302/312	
06.30.026	Harness with all sensors	E0836 LE202	
06.30.027	Connecting harness to PLC	E0836 LE202	
06.30.042	Harness with all sensors	E2876 E312	
06.30.043	Connecting harness to PLC	E2876 E312	
06.30.093	Harness with all sensors	E2876 TE302	
06.30.060	Connecting harness to PLC	E2876 TE302	
06.30.025	Harness with all sensors	E2876 LE202/302	
06.30.028	Connecting harness to PLC	E2876 LE202/302	
06.30.053	Harness with all sensors	E2848 LE322	
06.30.054	Connecting harness to PLC	E2848 LE322	
06.30.055	Harness with all sensors	E2842 E312	
06.30.056	Connecting harness to PLC	E2842 E312	
06.30.040	Harness with all sensors	E2842 LE312	
06.30.039	Adaptor harness	E2842 LE312	
06.30.041	Adaptor harness	E2842 LE312	
06.30.044	Connecting harness to PLC	E2842 LE312	
06.30.053	Harness with all sensors	E2842 LE322	
06.30.054	Connecting harness to PLC	E2842 LE322	
06.30.162	Harness with all sensors	E3262 LE202/212	
06.30.163-15000	Connecting harness to PLC	E3262 LE202/212	

## CAN Connecting Harnesses for Data Logger to PLC on MAN® E26 and E32 Series Gas Engines

P/N	Description	Connector	Length	Equivalent to
06.05.089-65	CAN connecting harness	4 pole, socket	65.00 ft. (20.00 m)	
06.05.092-65	CAN connecting harness	6 pole, socket	65.00 ft. (20.00 m)	

## Harnesses for WOODWARD® L-Series Control

P/N	Description	Connector	Length	Equivalent to
13.20.002	Programming harness for L-Series ITB, LC50	12 pole, socket	180.00 in. (4.60 m)	02-0004-174
13.20.003-295	Harness for L-Series	12 pole, socket	295.00 in. (7.50 m)	
13.20.003-590	Harness for L-Series	12 pole, socket	590.00 in. (15.00 m)	
13.20.004	Programming harness for L-Series	12 pole, socket	6.90 in. (0.18 m)	8923-1061

## Harnesses for WOODWARD® ProAct Series

P/N	Description	Connector	Length	Equivalent to
06.02.026-5	Harness for ProAct IV governor	MIL, 24 pole, socket, 90°	5.00 ft. (1.50 m)	
06.02.026-15	Harness for ProAct IV governor	MIL, 24 pole, socket, 90°	15.00 ft. (4.50 m)	
06.02.026-25	Harness for ProAct IV governor	MIL, 24 pole, socket, 90°	25.00 ft. (7.50 m)	
06.02.026-50	Harness for ProAct IV governor	MIL, 24 pole, socket, 90°	50.00 ft. (15.00 m)	
06.30.100	Harness for ProAct ISC integrated speed control	MIL, 24 pole, socket, 180°	50.00 ft. (15.00 m)	





## Air/Fuel Ratio Control Systems

### VariFuel2 MOTORTECH AIR/GAS MIXER

The VariFuel2 is a high-tech variable Venturi type mixer that can constantly adjust to any fuel changes and allows the engine to operate at its most efficient point. Series 100, 140, 200, 250, 300 and 350 are available for engines with an air requirement up to 12,000 m<sup>3</sup>/h. Coupled to an air/fuel ratio controller, lean-burn or stoichiometric, it precisely regulates the mixture. It is very popular for applications with constant changes in calorific value of fuel.

VariFuel2 uses a high precision stepper motor with an exclusive reprogrammable driver board (VariStep3). Various flow bodies and flexible inlet and outlet configurations allow fully flexible cross section adjustment.

Suitable for nearly all gas types:

- Natural gas
- Biogas
- Landfill gas
- Sewage gas
- Wood gas
- Wellhead gas
- Mine gas

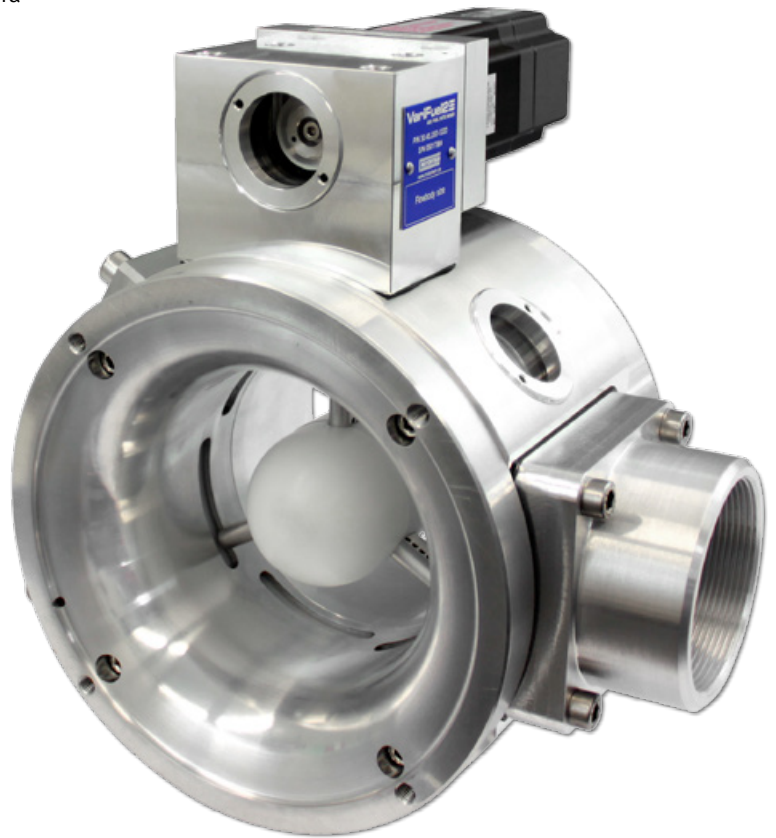
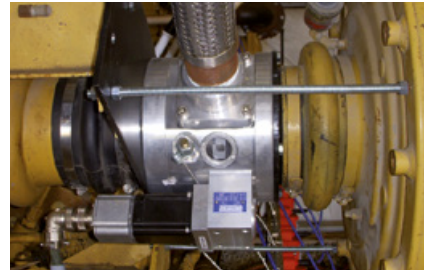
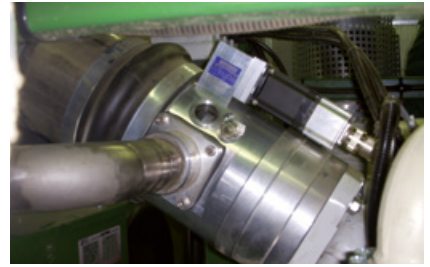

Stepper Motor Driver



Flow Bodies

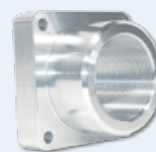

Gas Inlet Flanges



Outlet Flange Kits



# Air/Fuel Ratio Control Systems

## System Overview

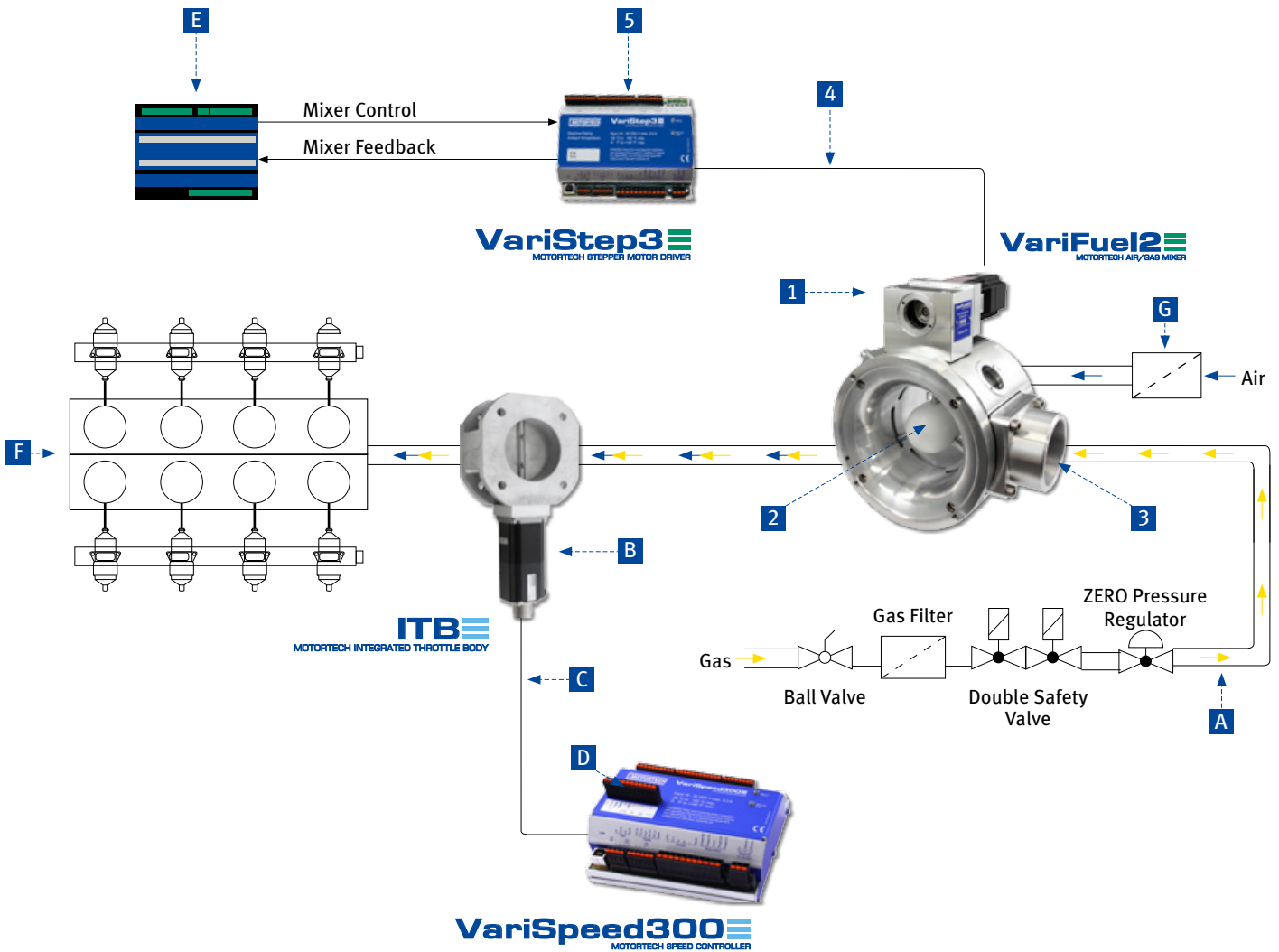

### Required Accessories

- 1** VariFuel2 air/gas mixer
- 2** Flow body
- 3** Gas inlet flange
- 4** Stepper motor harness
- 5** VariStep3 Stepper Motor Driver

### Accessories

- A** Gastrain (ZERO Pressure Regulator required)
- B** ITB throttle body with integrated stepper motor
- C** Stepper motor harness
- D** VariSpeed300 speed controller
- E** Emissions control system

### Description

- F** Engine
- G** Air filter

# Air/Fuel Ratio Control Systems



## 1 VariFuel2 Air/Gas Mixer – with Digital Stepper Motor<sup>1)</sup>

P/N	Supersedes	Description
30.45.100-60D	30.45.100-50D	VariFuel2 air/gas mixer, series 100-60
30.45.140-80D	30.45.140-65D	VariFuel2 air/gas mixer, series 140-80
30.45.200-120D	30.45.200-100D	VariFuel2 air/gas mixer, series 200-120
30.45.250-150D		VariFuel2 air/gas mixer, series 250-150
30.45.301-190D		VariFuel2 air/gas mixer, series 300-190
30.45.351-225D		VariFuel2 air/gas mixer, series 350-225



<sup>1)</sup> Consult factory for availability of manually adjustable VariFuel2 air/gas mixers.

## 2 Flow Bodies

P/N	Supersedes	Description	Diameter	VariFuel2 Series (D= digital / M= manual)					
				100-60D/M	140-80D/M	200-120D/M	250-150D/M	300-190D/M	350-225D/M
31.01.720-23.0-3		Flow body	23.0 mm	x	x	x	x		
31.01.720-27.5-3		Flow body	27.5 mm	x	x	x	x		
31.01.720-30.0-3		Flow body	30.0 mm	x	x	x	x		
31.01.720-32.5-3		Flow body	32.5 mm	x	x	x	x		
31.01.720-35.0-3		Flow body	35.0 mm	x	x	x	x	x	x
31.01.720-37.5-3		Flow body	37.5 mm	x	x	x	x		
31.01.720-40.0-3		Flow body	40.0 mm	x	x	x	x	x	x
31.01.720-42.5-3		Flow body	42.5 mm	x	x	x	x		
31.01.720-45.0-3		Flow body	45.0 mm	x	x	x	x	x	x
31.01.720-47.5-3		Flow body	47.5 mm	x	x	x	x		
31.01.720-50.0-3		Flow body	50.0 mm	x	x	x	x	x	x
31.01.720-52.5-3		Flow body	52.5 mm	x	x	x	x		
31.01.720-55.0-3		Flow body	55.0 mm	x	x	x	x	x	x
31.01.720-57.5-3		Flow body	57.5 mm		x	x	x		
31.01.720-60.0-3		Flow body	60.0 mm		x	x	x	x	x
31.01.720-62.5-3		Flow body	62.5 mm		x	x	x		
31.01.720-65.0-3		Flow body	65.0 mm		x	x	x	x	x
31.01.720-67.5-3		Flow body	67.5 mm		x	x	x		
31.01.720-70.0-3		Flow body	70.0 mm		x	x	x	x	x
31.01.720-72.5-3		Flow body	72.5 mm		x	x	x		
31.01.720-75.0-3		Flow body	75.0 mm			x	x	x	x
31.01.720-77.5-3		Flow body	77.5 mm			x	x		
31.01.720-80.0-3		Flow body	80.0 mm			x	x	x	x
31.01.720-82.5-3		Flow body	82.5 mm			x	x		
31.01.720-85.0-3		Flow body	85.0 mm			x	x	x	x
31.01.720-87.5-3		Flow body	87.5 mm			x	x		
31.01.720-90.0-3		Flow body	90.0 mm			x	x	x	x
31.01.720-92.5-3		Flow body	92.5 mm			x	x		
31.01.720-95.0-3		Flow body	95.0 mm			x	x	x	x
31.01.720-97.5-3		Flow body	97.5 mm			x	x		
31.01.720-100.0-3		Flow body	100.0 mm			x	x	x	x
31.01.720-102.5-3		Flow body	102.5 mm			x	x		
31.01.720-107.5-3		Flow body	107.5 mm			x	x		
31.01.720-110.0-3		Flow body	110.0 mm				x	x	x
31.01.720-115.0-3		Flow body	115.0 mm					x	x
31.01.720-120.0-3		Flow body	120.0 mm					x	x





# Air/Fuel Ratio Control Systems

## 2 Flow Bodies

P/N	Supersedes	Description	Diameter	VariFuel2 Series (D= digital / M= manual)					
				100-60D/M	140-80D/M	200-120D/M	250-150D/M	300-190D/M	350-225D/M
31.01.720-125.0-3		Flow body	125.0 mm					x	x
31.01.720-130.0-3		Flow body	130.0 mm					x	x
31.01.720-135.0-3		Flow body	135.0 mm					x	x
31.01.720-140.0-3		Flow body	140.0 mm					x	x
31.01.720-145.0-3		Flow body	145.0 mm						x
31.01.720-150.0-3		Flow body	150.0 mm						x

## Outlet Flange Kits

P/N	Description	VariFuel2 Series (D= digital / M= manual)					
		100-60D/M	140-80D/M	200-120D/M	250-150D/M	300-190D/M	350-225D/M
31.01.764	Outlet flange kit, gas relaxation section for throttle, series 50	x					
31.01.765	Outlet flange kit, gas relaxation section for throttle, series 100	x					
31.01.766	Outlet flange kit, gas relaxation section for throttle, series 50	x					
31.01.768	Outlet flange kit, for MAN® E0834 LE302/E0836 LE202	x					
31.01.750	Outlet flange kit, for MAN® E2876 LE202/212/302		x				
31.01.752	Outlet flange kit, welding neck flange, DN100		x				
31.01.753	Outlet flange kit, for MAN® E0836 LE202		x				
31.01.755	Outlet flange kit, DN65-PN6		x				
31.01.756	Outlet flange kit, for MAN® E2842 E312		x				
31.01.757	Outlet flange kit, for throttle, series 100		x				
31.01.762	Outlet flange kit, gas relaxation section for throttle, series 100		x				
31.01.763	Outlet flange kit, gas relaxation section for throttle, series 140		x				
31.01.773	Outlet flange kit, for LIEBHERR® G934/G944		x				
31.01.781	Outlet flange kit, for LIEBHERR® G946		x				
31.01.751	Outlet flange kit, welding neck flange, DN150			x			
31.01.754	Outlet flange kit, for MAN® E2842 E312			x			
31.01.758	Outlet flange kit, hose connection, DN200			x			
31.01.759	Outlet flange kit, for MAN® E2876 LE202/212/302			x			
31.01.761	Outlet flange kit, welding neck flange, DN150 – aluminum			x			
31.01.767	Outlet flange kit, for DEUTZ® TCG2015V6/V8			x			
31.01.772	Outlet flange kit, for SHENGDONG® 600GF1-PS			x			
31.01.774	Outlet flange kit, for LIEBHERR® G936			x			
31.01.775	Outlet flange kit, for LIEBHERR® G9508			x			
31.01.776	Outlet flange kit, for LIEBHERR® G9512			x			
31.01.777	Outlet flange kit, for LIEBHERR® G946/DOOSAN® GV158.3013.D			x			
31.01.779	Outlet flange kit, linkage for 2 VariFuel2 – series 200-1xx			x			
31.01.780	Outlet flange kit, for MAN® E2848/42 LE322/ E3268/62 LE2xx			x			

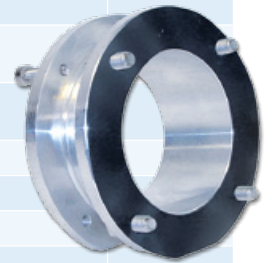

# Air/Fuel Ratio Control Systems



## 3 Gas Inlet Flanges

P/N	Description	Thread	VariFuel2 Series (D= digital / M= manual)					
			100-60D/M	140-80D/M	200-120D/M	250-150D/M	300-190D/M	350-225D/M
30.30.102	Gas inlet flange	G 1	x	x				
30.30.102-NPT	Gas inlet flange	1 NPT	x	x				
30.30.103	Gas inlet flange	G 1 1/4	x	x				
30.30.103-NPT	Gas inlet flange	1 1/4 NPT	x	x				
30.30.104	Gas inlet flange	G 1 1/2	x	x				
30.30.104-NPT	Gas inlet flange	1 1/2 NPT	x	x				
30.30.106	Gas inlet flange	G 1 1/2			x			
30.30.106-NPT	Gas inlet flange	1 1/2 NPT			x			
30.30.107	Gas inlet flange	G 2			x			
30.30.107-NPT	Gas inlet flange	2 NPT			x			
30.30.108	Gas inlet flange	G 2 1/2			x			
30.30.108-NPT	Gas inlet flange	2 1/2 NPT			x			
30.30.114	Gas inlet flange	G 4				x		
30.30.116	Gas inlet flange	G 5					x	
30.30.118	Gas inlet flange	G 6						x

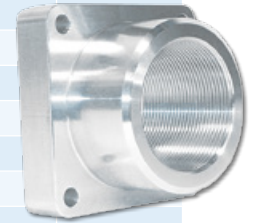

## 4 Stepper Motor Harness

P/N	Supersedes	Description	VariFuel2 Series (D= digital)					
			100-60D	140-80D	200-120D	250-150D	300-190D/M	350-225D/M
31.01.942		Stepper motor harness, MIL, 10 pole, socket , 90°, length 10 m (400 in.)	x	x	x	x	x	x

## 5 VariStep3 Stepper Motor Driver <sup>1)</sup>

P/N	Supersedes	Description	VariFuel2 Series (D= digital)					
			100-60D	140-80D	200-120D	250-150D	300-190D/M	350-225D/M
31.01.960	31.01.955	VariStep3 stepper motor driver	x	x	x	x	x	x

<sup>1)</sup> For multiple mixer applications each VariFuel2 air/gas mixer needs a single VariStep3 stepper motor card.

Air/Fuel Ratio Control Systems



4



5

# Air/Fuel Ratio Control Systems

## Isolation Amplifier <sup>1)</sup>

P/N	Figure	Description	VariFuel2 Series (D= digital)					
			100-60D	140-80D	200-120D	250-150D	300-190D/M	350-225D/M
63.02.017	<b>1</b>	Isolation amplifier, configurable	x	x	x	x	x	x

<sup>1)</sup> Used to pass on the position signal of an EmCon5 emissions controller to a second VariStep3 stepper motor driver. This way you can control two VariFuel2 air/gas mixers with one EmCon5 emissions controller on a V-engine.

## System Overview

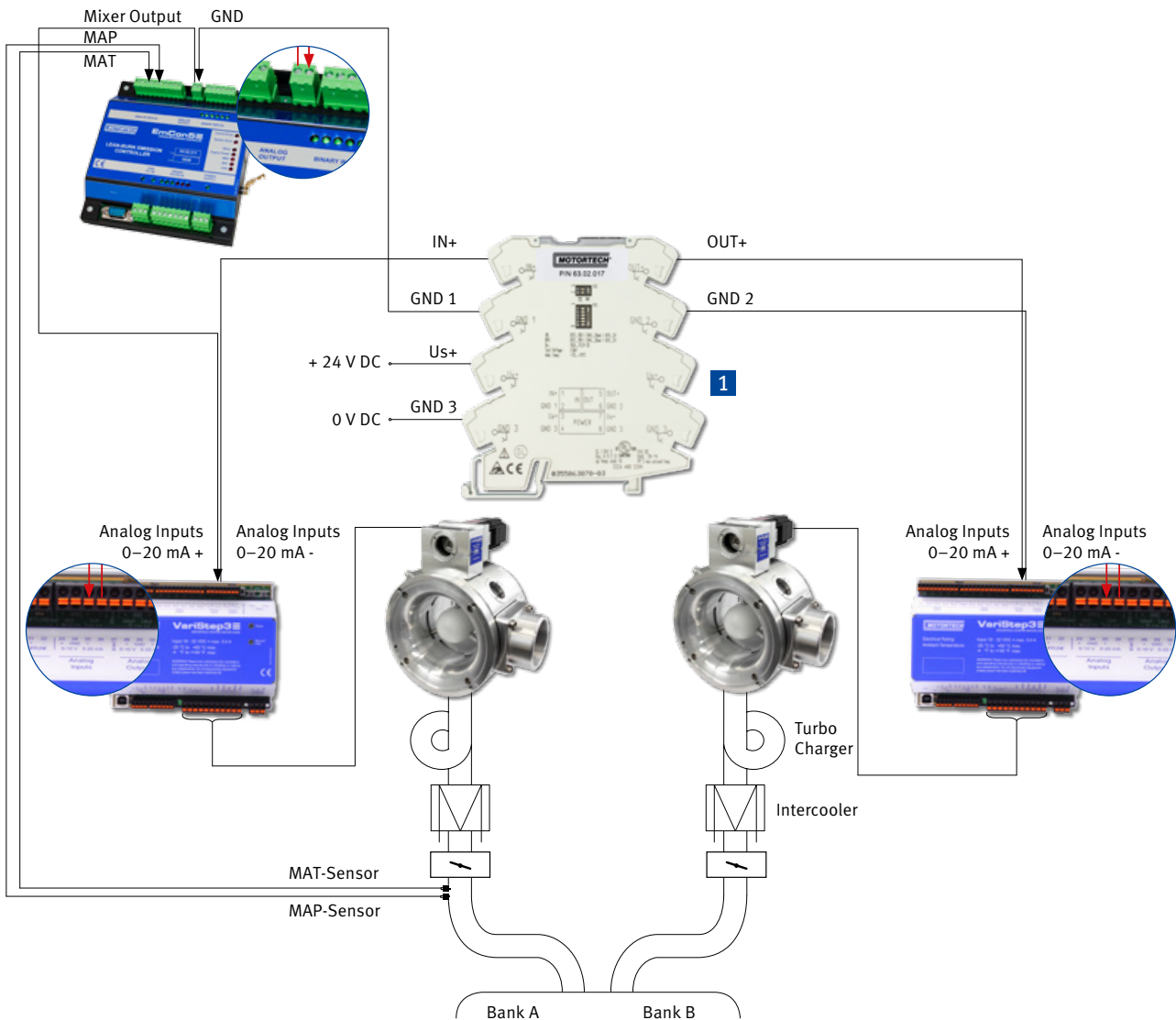

## Test Kit for Commissioning

P/N	Figure	Description	VariFuel2 Series (D= digital / M= manual)					
			100-60D/M	140-80D/M	200-120D/M	250-150D/M	300-190D/M	350-225D/M
01.56.001	1	Test Kit for commissioning, flow bodies for air/gas mixers	x	x	x	x	x	x

## Test and Calibration Box for VariStep Stepper Motor Cards and Stepper Motors

P/N	Figure	Description	VariFuel2 Series (D= digital)					
			100-60D	140-80D	200-120D	250-150D	300-190D/M	350-225D/M
31.01.965	2	Test and calibration box for VariStep stepper motor cards and stepper motors	x	x	x	x	x	x

## Tools for Repair and Maintenance

P/N	Figure	Description	VariFuel2 Series (D= digital / M= manual)					
			100-50D/M	100-60D/M	140-65D/M	140-80D/M	200-100D/M	200-120D/M
31.01.948-100	3	VariFuel2 adjustment tool for belt tension	x	x				
31.01.948-140	3	VariFuel2 adjustment tool for belt tension			x	x		
31.01.948-200	3	VariFuel2 adjustment tool for belt tension					x	x
31.01.948-250	3	VariFuel2 adjustment tool for belt tension						
31.01.948-300	3	VariFuel2 adjustment tool for belt tension						
31.01.948-350	3	VariFuel2 adjustment tool for belt tension						
31.01.943	4	VariFuel2 locking tool for toothed pulley	x	x	x	x	x	x
31.01.949	5	VariFuel2 tool for inspection window	x	x	x	x	x	x
31.01.959	6	VariFuel2 tool for maintenance cap, for series 100-50 up to S/N 05014433	x					



# Air/Fuel Ratio Control Systems

## Repair Kits for VariFuel2 air/gas mixers

P/N	Description	VariFuel2 Series (D= digital / M= manual)								
		100-50	100-60	140-65	140-80	200-100	200-120	250-150	300-190	350-225
31.01.997-1-100-50A	Basic kit, series 100-50 (up to S/N 05015052)	x(D/M)								
31.01.997-1-100-50B	Basic kit, series 100-50 (from S/N 05015053)	x(D/M)								
31.01.997-1-100-60	Basic kit, series 100-60		x(D/M)							
31.01.997-1-140-65	Basic kit, series 140-65			x(D/M)						
31.01.997-1-140-80	Basic kit, series 140-80				x(D/M)					
31.01.997-1-200-100A	Basic kit, series 200-100 (up to S/N 05010012)					x(D/M)				
31.01.997-1-200-100B	Basic kit, series 200-100 (from S/N 05010267)					x(D/M)				
31.01.997-1-200-120A	Basic kit, series 200-120 (up to S/N 05015009)						x(D/M)			
31.01.997-1-200-120B	Basic kit, series 200-120 (from S/N 05015201)						x(D/M)			
31.01.997-1-250-150	Basic kit, series 250-150							x(D/M)		
31.01.997-1-300-190	Basic kit, series 300-190								x(D/M)	
31.01.997-1-350-225	Basic kit, series 350-225									x(D/M)
31.01.997-2-100-50A	Stepper motor kit, Rev.A, series 100-50 <sup>1)</sup>	x(D)								
31.01.997-2-100-50B	Stepper motor kit, Rev.B, series 100-50	x(D)								
31.01.997-2-A	Stepper motor kit, Rev.A, series 140 to 200 <sup>1)</sup>			x(D)		x(D)	x(D)			
31.01.997-2-B	Stepper motor kit, Rev.B, series 140 to 350		x(D)	x(D)	x(D)	x(D)	x(D)	x(D)	x(D)	x(D)
31.01.997-3-100-50A	Outlet nozzle kit, series 100-50 (up to S/N 05015052)	x(D/M)								
31.01.997-3-100-50B	Outlet nozzle kit, series 100-50 (from S/N 05015053)	x(D/M)								
31.01.997-3-100-60	Outlet nozzle kit, series 100-60		x(D/M)							
31.01.997-3-140-65	Inlet nozzle kit, series 140-65			x(D/M)						
31.01.997-3-140-80	Outlet nozzle kit, series 140-80				x(D/M)					
31.01.997-3-200-100	Inlet nozzle kit, series 200-100					x(D/M)				
31.01.997-3-200-120A	Inlet nozzle kit, series 200-120 (up to S/N 05015009)						x(D/M)			
31.01.997-3-200-120B	Inlet nozzle kit, series 200-120 (from S/N 05015201)						x(D/M)			
31.01.997-3-250-150	Inlet nozzle kit, series 250-150							x(D/M)		
31.01.997-3-300-190	Outlet nozzle kit, series 300-190								x(D/M)	
31.01.997-3-350-225	Outlet nozzle kit, series 350-225									x(D/M)
31.01.997-4	Gauge ports kit, series 100 to 350	x(D/M)	x(D/M)	x(D/M)	x(D/M)	x(D/M)	x(D/M)	x(D/M)	x(D/M)	x(D/M)

<sup>1)</sup> Consult factory for availability.

## Gaskets for Outlet Flange Kits <sup>1)</sup>

Gasket		Included in	P/N Outlet Flange Kit
P/N VariFuel-Sided	P/N Engine-Sided		
31.01.365	03.90.050	Outlet flange kit, gas relaxation section for throttle, series 50	31.01.764
31.01.365	03.90.100	Outlet flange kit, gas relaxation section for throttle, series 100	31.01.765
31.01.858	03.90.050	Outlet flange kit, gas relaxation section for throttle, series 50	31.01.766
31.01.858	31.01.365	Outlet flange kit, for MAN® E0834 LE302/E0836 LE202	31.01.768
31.01.809	31.01.876	Outlet flange kit, for MAN® E2876 LE202/212/302	31.01.750
31.01.809		Outlet flange kit, welding neck flange, DN100	31.01.752
31.01.809	31.01.858	Outlet flange kit, for MAN® E0836 LE202	31.01.753
31.01.809	31.01.867	Outlet flange kit, DN65-PN6	31.01.755
31.01.809	31.01.871	Outlet flange kit, for MAN® E2842 E312	31.01.756
31.01.809	03.90.100	Outlet flange kit, for throttle, series 100	31.01.757
31.01.809	03.90.100	Outlet flange kit, gas relaxation section for throttle, series 100	31.01.762
31.01.809	03.90.140	Outlet flange kit, gas relaxation section for throttle, series 140	31.01.763
31.01.809		Outlet flange kit, for LIEBHERR® G934/G944	31.01.773
31.01.809		Outlet flange kit, for LIEBHERR® G946	31.01.781
31.01.828		Outlet flange kit, welding neck flange, DN150	31.01.751
31.01.828	31.01.863	Outlet flange kit, for MAN® E2842 LE312	31.01.754
31.01.828		Outlet flange kit, hose connection, DN200	31.01.758
31.01.879	31.01.879	Outlet flange kit, for MAN® E2876 LE202/212/302	31.01.759
31.01.828		Outlet flange kit, welding neck flange, DN150 – aluminum	31.01.761
31.01.828	31.01.886	Outlet flange kit, for DEUTZ® TCG2015V6/V8	31.01.767
31.01.371, 31.01.828	31.01.371, 31.01.372	Outlet flange kit, for SHENGDONG® 600GF1-PS	31.01.772
31.01.828		Outlet flange kit, for LIEBHERR® G936	31.01.774
31.01.828		Outlet flange kit, for LIEBHERR® G9508	31.01.775
31.01.828		Outlet flange kit, for LIEBHERR® G9512	31.01.776
31.01.828		Outlet flange kit, for LIEBHERR® G946/DOOSAN® GV158.3013.D	31.01.777
31.01.828		Outlet flange kit, for LIEBHERR® G9508	31.01.778
31.01.828	31.01.377	Outlet flange kit, linkage for 2 VariFuel2 – series 200-1xx	31.01.779
31.01.828	31.01.828	Outlet flange kit, for MAN® E2848/42 LE322/ E3268/62 LE2xx	31.01.780

<sup>1)</sup> Gaskets included in each outlet flange kit.

# Air/Fuel Ratio Control Systems

## VariStep3 MOTORTECH STEPPER MOTOR DRIVER

The stepper motor driver developed by MOTORTECH guarantees the ideal control of the various types of MOTORTECH VariFuel2 air/gas mixers and throttle bodies with integrated stepper motor.

- Precise mixer and throttle adjustment due to microstep operation
- Very fast response times
- Increased power output provides high torque and quick movement even when driving big stepper motors
- Accelerated reference run
- LEDs displaying unit status and activity
- Combination of several units without signal amplifier/splitter
- Integrated CANopen and Modbus RTU interface
- Configuration via MICT software
- Error data logging for improved diagnostic options
- Compact design
- Plug-in terminals
- Easy access to connectors and switches
- Switch board installation on DIN rail



### VariStep3 Stepper Motor Driver for VariFuel2 Air/Gas Mixer and ITB Integrated Throttle Bodies

P/N	Supersedes	Description
31.01.960	31.01.955	VariStep3 stepper motor driver

#### Technical Data

- 18 to 32 VDC power supply
- -20 °C up to +60 °C (-4 °F up to 140 °F) ambient temperature
- 0 to 20 mA/ 0-10V analog input and output, flexible configuration
- 5 digital inputs, 5 to 32 V compatible, DC-isolated
- 6 digital outputs, up to 32 V, 100 mA, DC-isolated

#### Interfaces

- CAN Bus 2.0b interface (CANopen protocol)
- RS485 interface (Modbus RTU)
- USB 1.1 interface

#### Configuration

- Using the graphic user interface MICT (MOTORTECH Integrated Configuration Tool)
- Manual control via push-button

#### Housing

- Protection class IP 20
- Dimensions 160 x 126 x 62 mm (6.3 x 5.0 x 2.4 in.)



## EmCon5

MOTORTECH LEAN-BURN EMISSION CONTROLLER

The EmCon5 is a lean-burn emission controller for gas engine co-generation units. It is designed to control the exhaust gas emission levels based on indirect measurements. Simply three input signals are required for the control purpose: manifold inlet pressure and temperature and engine load. A CH<sub>4</sub> input signal is optional. Use of an oxygen sensor is not required.

Following initial measurements of the engine emission levels and successful analysis, the EmCon5 guarantees optimal operation of the gas engine at the pre-defined emission limits.

All controller parameters are freely programmable. The adjustments and modifications are made via the computer-program "WinScope". The EmCon5 fits perfectly with the VariFuel2 air/gas mixer.



### Features

- Standardized system available
- Operates without oxygen sensor
- Two gas qualities programmable
- Easy to use
- Available with complete sensor harness (optional)
- Data logging
- Flexible control for reliable operation with biogas

# Air/Fuel Ratio Control Systems

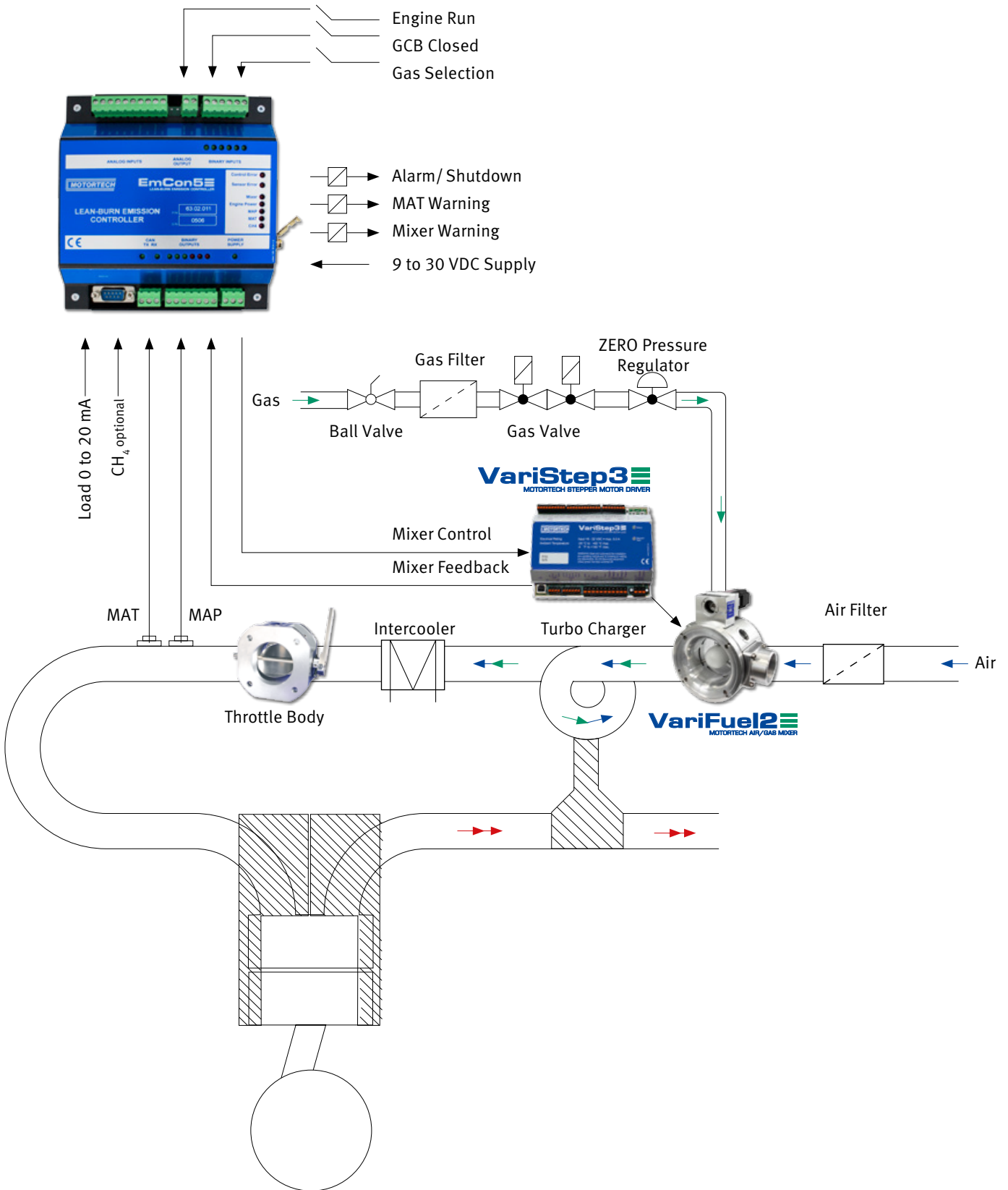

## Control Unit

P/N	Figure	Supersedes	Description	Equivalent to
63.02.011	1		EmCon5 lean burn emission control unit	

## Sensor Harness

P/N	Figure	Supersedes	Description	Equivalent to
06.30.045	2		EmCon5 sensor harness, including MAT sensor P/N 56.01.004 and MAP sensor P/N 56.02.017	

## MAT – Manifold Air Temperature Sensors

P/N	Figure	Supersedes	Description	Thread	Fitting Length	Equivalent to
56.01.004	3	56.01.021	MAT sensor	G1/2 in.	2.00 in. (50 mm)	
56.01.011	3		MAT sensor	G1/2 in.	3.00 in. (75 mm)	
56.01.017	3		MAT sensor	G1/2 in.	4.00 in. (100 mm)	

## MAP – Manifold Absolute Pressure Sensor (Industrial Design)

P/N	Figure	Supersedes	Description	Thread	Pressure Range	Equivalent to
56.02.017	4	56.02.016	MAP sensor	G1/4 in.	0 to 3.0 bar	

## Load Transducer

P/N	Figure	Supersedes	Description	Equivalent to
63.02.013	5		Load transducer, 0 to 5 A → 0 to 20 mA/4 to 20 mA/0 to 10 V/2 to 10 V	



# Air/Fuel Ratio Control Systems



## VariSCR NOx Emission Controller for SCR Catalytic Converters

MOTORTECH developed the new NO<sub>x</sub> emission controller VariSCR to satisfy the increasing immission protection requirements in the future from the amendment to the emission values in TA-Luft (Technical Instructions on Air Quality Control). In addition to the exhaust aftertreatment the VariSCR can also control the air/fuel ratio control system.

After a transition time up to 2018, NO<sub>x</sub> reduction from a current 500 mg/m<sup>3</sup> to 100 mg/m<sup>3</sup> for natural gas CHP applications (based on a reference oxygen content of 5% by volume) will become obligatory for new and existing CHP plants. To bring about constant reduction of NO<sub>x</sub>-emissions in the SCR (Selective Catalytic Reduction) system, AdBlue<sup>®</sup>, a solution of 32.5% urea in water, will be injected into the exhaust gas flow in front of the SCR catalytic converter. The urea is converted into ammonia through thermolysis and hydrolysis. In the SCR catalytic converter, the ammonia then reduces the nitrogen oxides to water and nitrogen.

Besides the algorithms for NO<sub>x</sub> reduction, the software also contains controllers for controlling the pump module to maintain constant delivery pressure, the heating controller for the dosing unit as well as optionally the fill-level monitoring in the AdBlue<sup>®</sup>-storage tank.

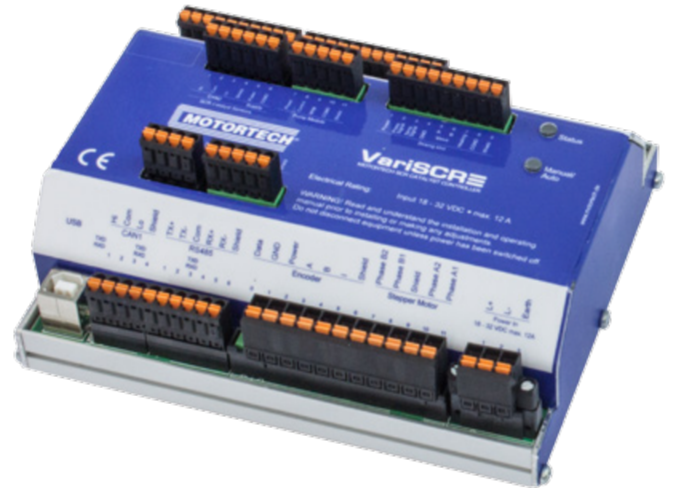

- VariSCR NO<sub>x</sub> emission controller
- wiring harness for pump module
- wiring harness for dosing unit
- sensor harnesses

### Features

- Read out of the NO<sub>x</sub> sensors in front of and behind the catalytic converter
- Control of the urea injection to the NO<sub>x</sub> set-point value through monitoring of the raw and target emission after the SCR catalytic converter
- Control of the urea pump for controlling and monitoring the AdBlue<sup>®</sup> injection quantity, temperature, and the delivery pressure
- Regulation of the AdBlue<sup>®</sup> heating and circulation
- Fault detection and diagnostics
- Connection to the overriding controller via CAN-Bus
- Air/fuel ratio control possible through control of the VariFuel2 air/gas mixer

# Air/Fuel Ratio Control Systems

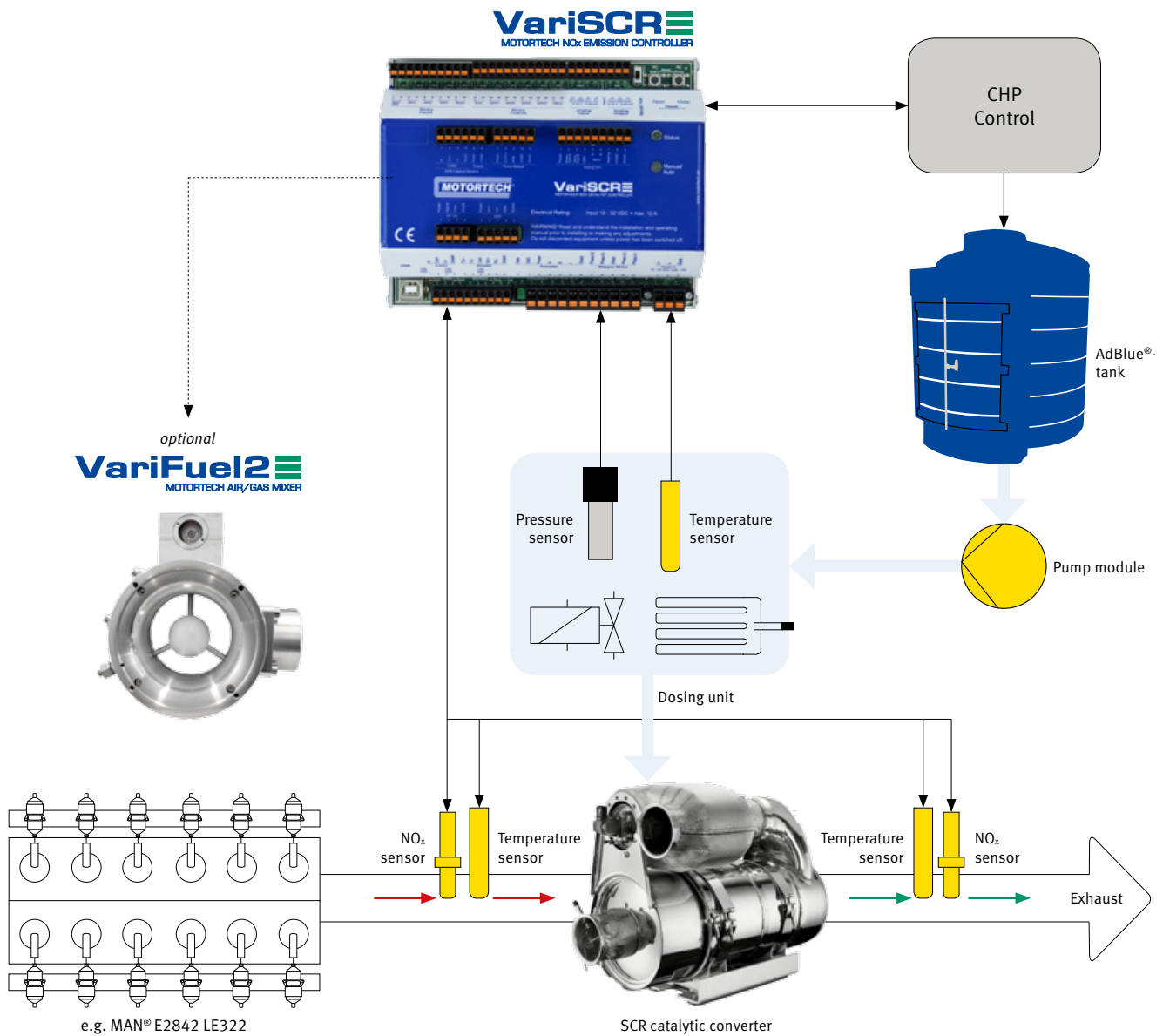

Air/Fuel Ratio Control Systems

## Technical data

- 18 to 32 VDC power supply
- -20 °C to +60 °C (-4 °F up to 140 °F) permitted ambient temperature
- 0 to 20 mA/0 to 10 V analog input and output, freely configurable
- 5 digital inputs, 5 to 32 V, compatible, galvanic separation
- 6 digital outputs, up to 32 V, 100 mA, galvanic separation

## Interfaces

- 2 CAN Bus 2.0b interfaces (CANopen protocol)
- RS485 interface (Modbus RTU)
- USB 1.1 interface

## Configuration

- Using the graphical user interface MICT (MOTORTECH Integrated Configuration Tool)

## Housing

- Protection class IP 20
- Dimensions 160 x 126 x 62 mm (6.3 x 5.0 x 2.4 inches)







## Gas Engine Accessories

# OLC

MOTORTECH OIL LEVEL CONTROLLER

Combustion engines, compressors, turbines, slide bearings and gears – they all depend on a reliable supply of lubricating oil. For trouble-free operation, each of those systems, dependent on the design, requires a precisely defined oil level that may only be exceeded or undercut by a narrow margin. Moreover, the lubricating capacity of the oil is depleted after a certain operating time – it has to be changed.

Oil level monitoring, oil refill, and even an automated oil change – in other words, the complete management of the oil cycle – can be realized in a completely reliable manner with MOTORTECH's OLC oil level controller.

### Advantages for the User

- Elimination of regular monitoring of the oil level
- Operation is not interrupted for monitoring the oil level
- Operating errors are avoided, no overfilling/lack of oil
- Automated oil change possible
- Less work for staff, increase in operational safety
- Visual surveillance of the oil level during operation is possible
- Remote monitoring from a central location

### Features

- Housing made of a high-grade, saltwater-resistant aluminum alloy
- Individually and infinitely adjustable float switches with reed contacts
- Potential-free closing or opening switches, no voltage transfer
- One-shot switches with step response and unambiguous switching states
- Contacts do not come into contact with oil, protection class IP 65
- Vibration-proof, no interference caused by worn rods/valve seats
- 2, 3 or 4 contacts
- Optional analog level indicator 4 to 20 mA
- Floats resistant to all oils
- Contact protection thanks to integrated resistor
- Switch point adjustment requires the use of tools

- Fail-safe wires
- Suitable for mineral and synthetic oils
- 2 oil and 2 equalization connectors
- Pipe connections with standard inch threads
- Sight glass made of impact-resistant polycarbonate
- Glass sealed with Perbunan (NBR)
- Interior painted white for optimal recognition of oil level
- Slotted holes allow for height adjustment during installation
- Indication of engine wear based on refill frequency
- Indication of water in lubricating oil is possible

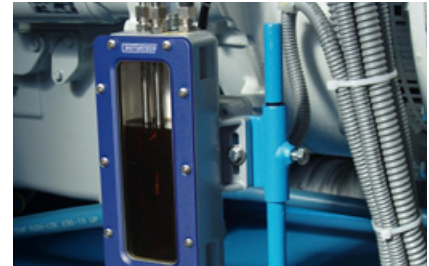

## Product Variants

### Oil Level Controller with Float Switches

The devices of this OLC version are ideal for use with gas engines and they stand out for their reliable monitoring of the oil level.

The housing, made of a saltwater-resistant aluminum alloy, accommodates 2, 3 or 4 float switches. The float switches are screwed into the housing with a clamp screw connection. Any immersion depth can be adjusted with a swivel nut, which makes it possible to set the desired switch point. Subsequent readjustment is also possible without any problems.

A large sight glass made of impact-resistant polycarbonate enables the visual assessment of the current oil level. The white inner coating facilitates viewing even with poor light conditions.

The slotted holes and the optional use of the vertical or horizontal pipe connection threads constitute significant advantages during the installation.

### Float Switch (displayed as MIN Contact)

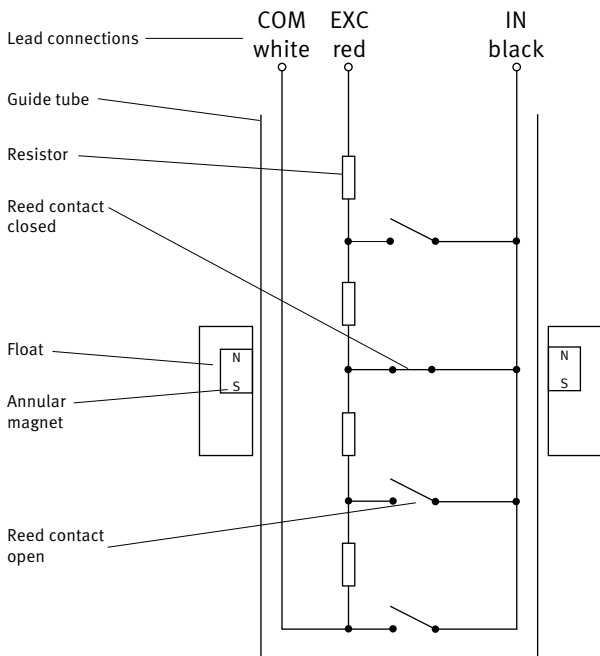
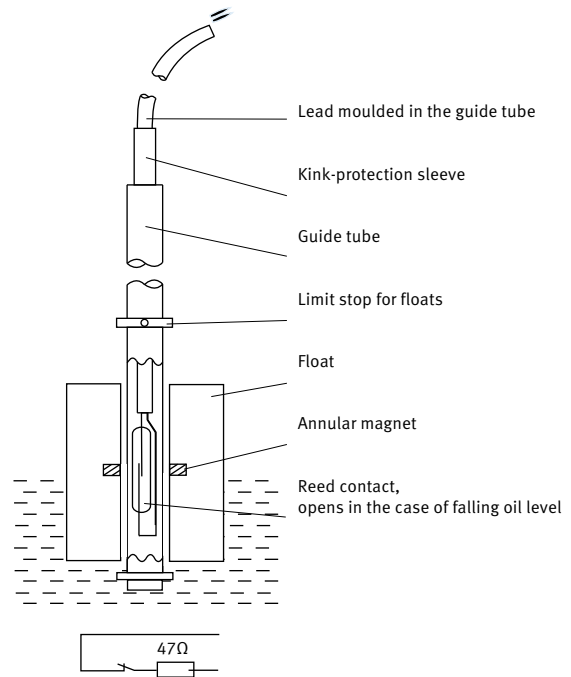

### Oil Level Controller with analog Level Sensor

Unlike an oil level controller with float switches, this OLC version uses reed contacts that are distributed evenly in the guide tube across the entire measuring range of 125 mm. Every reed contact is connected to a resistor. When the float rises or falls with the oil level, the magnetic forces of an annular magnet activate a reed contact through which an electrical current flows. The aforementioned resistors bring about a type of sliding resistance. The variable electrical signal, created by different resistance values, is converted into a standard signal within a range of 4 to 20 mA by a measuring transducer that is connected by cable. This signal can be used in many different ways in a control system (e. g. ALL-IN-ONE). A visual display on a screen or an LED bar graph is also possible.

Two versions of the OLC can be equipped with one or two float switches in addition to the analog sensor in order to provide a redundant monitoring signal for the minimum or maximum oil level.

# Gas Engine Accessories

## Automatic Oil Refill

Monitoring the optimal oil level and signaling a lack of oil or overfilling with the OLC oil level controller is imperative for stationary gas engines that are in continuous operation. Therefore, upgrading to an automatic oil refill is logical and enables operation without supervision.

If the oil level falls short of the switch point for the refill contact (or the set electrical current with an analog sensor), then the engine control system sends a signal to the refill valve or to a refill pump. Fresh oil will be supplied to the engine until the refill contact interrupts the flow of oil.

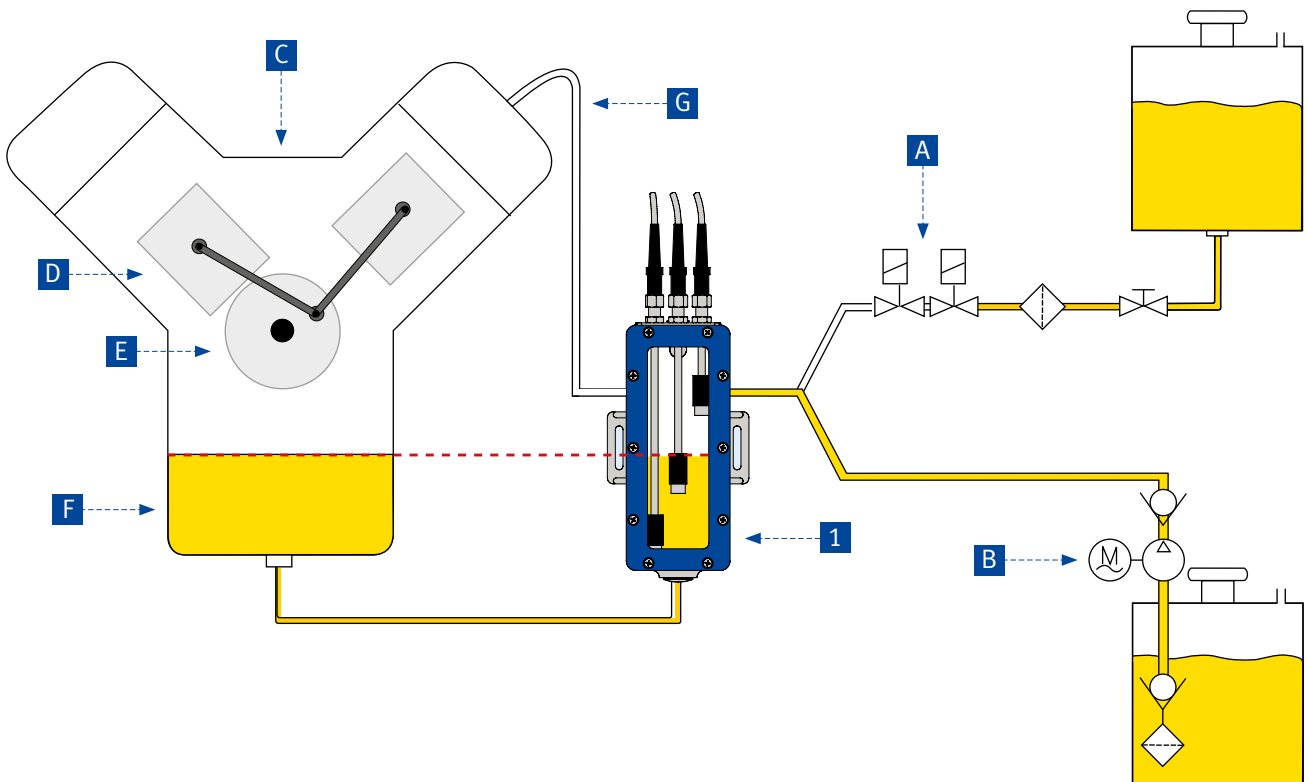

### Required Accessories

- 1 OLC oil level controller

### Accessories

- A Solenoid/double solenoid valve <sup>1)</sup>  
alternative
- B Oil pump <sup>2)</sup>

### Description

- C Engine
- D Piston
- E Crankshaft
- F Oil pan
- G Compensation line

<sup>1)</sup> An oil storage tank positioned above the engine, from which the oil flows by gravity, requires a solenoid valve for blocking, or better yet a double solenoid valve for reasons of redundancy.

<sup>2)</sup> An oil storage tank located below the engine must be equipped with an electric pump.

## 1 Oil Level Controllers with Analog Level Sensor 4 to 20 mA – Transducer in Metal Housing

P/N	Description	Float Switch	Cable Length	Cable Insulation
80.01.214	OLC oil level controller with analog level sensor		4.0 m	PVC
80.01.214-1104	OLC oil level controller with analog level sensor	MIN	4.0 m	PVC
80.01.214-1204	OLC oil level controller with analog level sensor	MAX	4.0 m	PVC
80.01.214-2104	OLC oil level controller with analog level sensor	MIN/MAX	4.0 m	PVC

## 1 Oil Level Controllers with two Float Switches

P/N	Description	Cable Length	Cable Insulation
80.01.210-2001	OLC oil level controller	1.0 m	PVC
80.01.210-2004	OLC oil level controller	4.0 m	PVC

## 1 Oil Level Controllers with three Float Switches

P/N	Description	Cable Length	Cable Insulation
80.01.210-3001	OLC oil level controller	1.0 m	PVC
80.01.210-3004	OLC oil level controller	4.0 m	PVC

## 1 Oil Level Controllers with four Float Switches

P/N	Description	Cable Length	Cable Insulation
80.01.210-4001	OLC oil level controller	1.0 m	PVC
80.01.210-4004	OLC oil level controller	4.0 m	PVC

## A Double Solenoid Valves

P/N	Description	Coil Voltage	Maximum Pressure	Cable Length	Cable Insulation
81.00.310-01	Double solenoid valve, 2/2 way	230 V/50 Hz	24 bar	1.0 m	PVC
81.00.310-04	Double solenoid valve, 2/2 way	230 V/50 Hz	24 bar	4.0 m	PVC
81.00.311-01	Double solenoid valve, 2/2 way	24 V	16 bar	1.0 m	PVC
81.00.311-04	Double solenoid valve, 2/2 way	24 V	16 bar	4.0 m	PVC
81.00.312-01	Double solenoid valve, 2/2 way	12 V	16 bar	1.0 m	PVC
81.00.312-04	Double solenoid valve, 2/2 way	12 V	16 bar	4.0 m	PVC
81.00.313-01	Double solenoid valve, 2/2 way	24 V/50 Hz	24 bar	1.0 m	PVC
81.00.313-04	Double solenoid valve, 2/2 way	24 V/50 Hz	24 bar	4.0 m	PVC

## A Solenoid Valves

P/N	Description	Coil Voltage	Maximum Pressure	Cable Length	Cable Insulation
81.00.300-01	Solenoid valve, 2/2 way	230 V/50 Hz	24 bar	1.0 m	PVC
81.00.300-04	Solenoid valve, 2/2 way	230 V/50 Hz	24 bar	4.0 m	PVC
81.00.301-01	Solenoid valve, 2/2 way	24 V	16 bar	1.0 m	PVC
81.00.301-04	Solenoid valve, 2/2 way	24 V	16 bar	4.0 m	PVC
81.00.302-01	Solenoid valve, 2/2 way	12 V	16 bar	1.0 m	PVC
81.00.302-04	Solenoid valve, 2/2 way	12 V	16 bar	4.0 m	PVC
81.00.303-01	Solenoid valve, 2/2 way	24 V/50 Hz	24 bar	1.0 m	PVC
81.00.303-04	Solenoid valve, 2/2 way	24 V/50 Hz	24 bar	4.0 m	PVC

## B Oil Pumps

P/N	Description	Voltage	Connected Load	Protection class	Max. Pump Capacity	Max Pressure
81.00.510	Oscillating piston pump	230 V/50 Hz	30 W	IP 66	0.4 l/min.	0.7 bar
81.00.511	Oscillating piston pump	230 V/50 Hz	60 W	IP 65	1.5 l/min.	2.5 bar

# Gas Engine Accessories

## Coolant Filtration

### Stainless Steel Coolant Filters for Stationary Applications

These bypass filters with stainless steel filter elements clean coolant liquids from all deposits. Elements can be washed and do not need to be disposed. Increases water pump life, cylinder head efficiency and equipment availability. Reduces service and maintenance cost.

Coolant should be clean and clear!

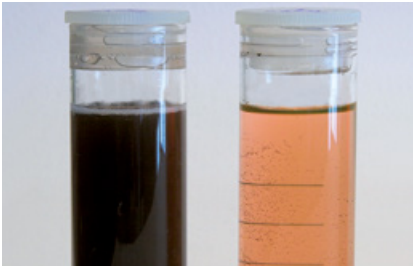

### Features

- Easy to install
- Cleans and maintains coolant system from rust and contaminants
- Increases water pump life
- Reduces coolant deposits and increases cylinder head efficiency and life
- Stainless steel filter elements can be cleaned – NO WASTE
- Visual flow indicator (stationary applications)
- Easy to service – decreases maintenance cost
- Filter micron rating: standard – 50 micron optional – 25 micron
- Flow rate up to 30 GPM

### Technical Advantage

- Inhibits electro-chemical degradation of engine components. An industrial gas engine has the characteristics of a large battery when coolant is circulated through the engine block. Contaminants and suspended solids in the coolant act as a conductor, which more readily allows current to flow throughout the engine block, which degrades EPDM, buna, rubber, viton, and soft metal or alloy components / water pump bearings, impellers, etc.
- Cleaned coolant inhibits corrosion on engine components such as cylinder heads, cylinder liners and seals, water pump impellers and bearings, etc.
- Prevents “flash-off” in the cylinder heads when engine has an emergency stop; as the coolant can properly dissipate thermal loads
- Inhibits scale deposits on all coolant passages and interior thermal surfaces of the engine block.

# Gas Engine Accessories



Standard – For Temperatures up to 200 °F/95 °C

P/N	Figure	Description	Element Outside Diameter	Element Length	Micron Rating <sup>1)</sup>	Stand	Flow Indicator	Equivalent to
25.00.009-50-30	1	Coolant filter	5.00 in.	9.00 in.	50	30.00 in.	X	486501
25.00.009-50	1	Coolant filter	5.00 in.	9.00 in.	50		X	
25.00.018-50-49	1	Coolant filter	5.00 in.	18.00 in.	50	49.00 in.	X	489625
25.00.018-50	1	Coolant filter	5.00 in.	18.00 in.	50		X	

<sup>1)</sup> For 25 micron filter elements please change part number from -50 to -25.

High Temperature – For Temperatures from 200 °F/95 °C up to 400 °F/205 °C

P/N	Figure	Description	Element Outside Diameter	Element Length	Micron Rating <sup>1)</sup>	Stand	Flow Indicator	Equivalent to
25.00.009-50-30-HT	1	Coolant filter	5.00 in.	9.00 in.	50	30.00 in.	X	
25.00.009-50-HT	1	Coolant filter	5.00 in.	9.00 in.	50		X	
25.00.018-50-49-HT	1	Coolant filter	5.00 in.	18.00 in.	50	49.00 in.	X	
25.00.018-50-HT	1	Coolant filter	5.00 in.	18.00 in.	50		X	

<sup>1)</sup> For 25 micron filter elements please change part number from -50 to -25.

## Single Filter Elements

P/N	Figure	Description	Element Outside Diameter	Element Length	Micron Rating	Equivalent to
25.00.109-25	2	Coolant filter element	5.00 in.	9.00 in.	25	
25.00.109-50	2	Coolant filter element	5.00 in.	9.00 in.	50	489508
25.00.118-25	2	Coolant filter element	5.00 in.	18.00 in.	25	
25.00.118-50	2	Coolant filter element	5.00 in.	18.00 in.	50	489626

## Shipping Cases for Filter Elements

P/N	Figure	Description	For Element Length	Equivalent to
25.00.209	3	Shipping case	9.00 in.	
25.00.218	3	Shipping case	18.00 in.	





# Gas Engine Accessories



## Lube Oil Filtration

### Stainless Steel Lube Oil Filters

The re-cleanable stainless steel filters for oil filtration are the environmentally friendly alternative to commonly used disposable filters.

Due to re-using of elements, payback starts immediately after installation. Filters are available as replacements for OEM filter elements or custom made to fit your application.

#### Efficiency & Design Benefits

- 100% stainless construction
- Increased surface area and flow rates
- Longer Fluid Life
- High heat tolerances
- High resistance to chemicals and corrosion
- Extended maintenance intervals
- Improves filtration performance
- Absolute rated contaminant removal
- Direct OEM replacements which require no modification

#### Environmental Benefits

- Eliminates disposal costs
- Eliminates disposal liability
- Reduce landfill waste and environmental harm
- Recyclable

#### Economical Benefits

- Reduce inventory needs and costs
- A one-time cost that pays back quickly
- Environmentally friendly



### 100% Stainless Steel Construction

Stainless steel micronic wire cloth available in micron ratings of 3-400 absolute. Welded serial #, ID tag

304 or 316, 20-gauge stainless steel perforated inner/outer tube 3/16 in. on 1/4 in. centers

High heat resistant adhesive attaches end caps to filter

Seals available in Buna-N, HSN, Teflon and Viton to suit your application

### Stainless Steel Replacement Elements available for:

#### Engine and Compressor Filters

WAUKESHA®  
WHITE SUPERIOR®  
CATERPILLAR®  
INGERSOLL RAND®  
COOPER BESSEMER®  
AJAX®

HERCULES®  
GARDNER®  
DENVER®  
ATLAS®  
CORPCO®

#### Process and Hydraulic Filters

PECO®  
PALL®  
PEACOCK®  
CUNO®  
FILTERITE®  
NOWATA®  
SCHROEDER®  
POROUS MEDIA®  
FAIREY ARLON®  
UCC®  
STAUFF®

BALDWIN®  
FACET®  
FRAM®  
HILCO®  
REFILCO®  
NUGENT®  
VICKERS®  
GRESN®  
HYCON®  
PARKER®  
HYTREX®



## Filter Element Kits <sup>1)</sup>

P/N	Description	Element Outside Diameter	Element Length	Micron Rating	Number of Elements	Application	Equivalent to
25.00.300-1-CA	Lube filter element kit	7.00 in.	30.00 in.	38	1	CATERPILLAR® G3508/12/16	
25.00.301-6-CA	Lube filter element kit	7.00 in.	13.00 in.	38	6	CATERPILLAR® G3606/08/12/16	
25.00.303-1-CA	Lube filter element kit	5.00 in.	9.00 in.	38	1	CATERPILLAR® G3406/08	
25.00.310-4-WA	Lube filter element kit	3.00 in.	15.00 in.	25	4	WAUKESHA®	167602B
25.00.310-7-WA	Lube filter element kit	3.00 in.	15.00 in.	25	7	WAUKESHA®	167602B
25.00.310-14-WA	Lube filter element kit	3.00 in.	15.00 in.	25	14	WAUKESHA®	167602B
25.00.311-4-WA	Lube filter element kit	3.00 in.	30.00 in.	25	4	WAUKESHA®	168660B, 489493
25.00.311-7-WA	Lube filter element kit	3.00 in.	30.00 in.	25	7	WAUKESHA®	168660B, 489493
25.00.312-1-WA	Lube filter element kit	5.00 in.	7.00 in.	75	1	WAUKESHA®	208472B, 489488
25.00.313-1-WA	Lube filter element kit	5.00 in.	10.00 in.	75	1	WAUKESHA®	208472C, 489489
25.00.314-10-WA	Lube filter element kit	3.00 in.	30.00 in.	25	10	WAUKESHA®	168660H
25.00.320-3-WS	Lube filter element kit	4.00 in.	18.00 in.	25	3	WHITE SUPERIOR® 6G/GT/GTL/GTLA-B	
25.00.320-4-WS	Lube filter element kit	4.00 in.	18.00 in.	25	4	WHITE SUPERIOR® 8G/GT/GTL/GTLA-B/SGTB	
25.00.320-5-WS	Lube filter element kit	4.00 in.	18.00 in.	25	5	WHITE SUPERIOR® 12G/GT/GTL/GTLA-B/SGT/SGTA-B	
25.00.320-7-WS	Lube filter element kit	4.00 in.	18.00 in.	25	7	WHITE SUPERIOR® 16G/GT/GTL/GTLA-B/SGT/SGTA-B	
25.00.330-1-AR	Lube filter element kit	4.00 in.	9.00 in.	38	1	ARIEL®	A-661, A-0661

<sup>1)</sup> All steel lube filter element kits are supplied with a shipping case.

## Single Filter Elements

P/N	Description	Element Outside Diameter	Element Length	Micron Rating	Element Kit	Engine Manufacturer	Equivalent to
25.00.300-CA	Lube filter element	7.00 in.	30.00 in.	38	25.00.300-1-CA	CATERPILLAR® (Triple Length Element)	
25.00.301-CA	Lube filter element	7.00 in.	13.00 in.	38	25.00.301-6-CA	CATERPILLAR®	1W-4136
25.00.302-CA	Lube filter element	7.00 in.	10.00 in.	38		CATERPILLAR®	1R-0726
25.00.303-CA	Lube filter element	5.00 in.	9.00 in.	38	25.00.303-1-CA	CATERPILLAR®	1R-0716, B99
25.00.310-WA	Lube filter element	3.00 in.	15.00 in.	25	25.00.310-4/-7/-14-WA	WAUKESHA®	167602B
25.00.311-WA	Lube filter element	3.00 in.	30.00 in.	25	25.00.311-4/-7-WA	WAUKESHA®	168660B, 489493
25.00.312-WA	Lube filter element	5.00 in.	7.00 in.	75	25.00.312-1-WA	WAUKESHA®	208472B, 489488
25.00.313-WA	Lube filter element	5.00 in.	10.00 in.	75	25.00.313-1-WA	WAUKESHA®	208472C, 489489
25.00.314-WA	Lube filter element	3.00 in.	30.00 in.	25	25.00.314-10-WA	WAUKESHA®	168660H
25.00.315-WA	Lube filter element	5.00 in.	17.00 in.	25		WAUKESHA®	489491, 305351E
25.00.316-WA	Lube filter element	4.00 in.	8.00 in.	25		WAUKESHA®	489495, 304126
25.00.317-WA	Lube filter element	5.00 in.	12.00 in.	25		WAUKESHA®	489490, 305315C
25.00.318-WA	Lube filter element	4.00 in.	16.00 in.	25		WAUKESHA®	172607, 489522
25.00.320-WS	Lube filter element	4.00 in.	18.00 in.	25	25.00.320-3/-4/-5/-7-WS	WHITE SUPERIOR®	758-133
25.00.330-AR	Lube filter element	4.00 in.	9.00 in.	38	25.00.330-1-AR	ARIEL®	A-661, A-0661
25.00.335-EMD	Lube filter element	6.00 in.	30.00 in.	38		EMD® Locomotive Engines	8345482

## Accessories

P/N	Description	For use with Element Kit	Equivalent to
25.00.222	Pressure gauge, liquid filled		
25.00.226	Grommet seal	25.00.311-WA	
25.00.228	Grommet seal, Viton	25.00.300-CA, 25.00.302-CA	
25.00.229	Seal kit	25.00.330-1-AR	
25.00.231	Grommet seal, Viton	25.00.310-WA, 25.00.311-WA, 25.00.314-WA	

# Gas Engine Accessories

## Ultrasonic Cleaning Equipment

### Ultrasonic Cleaning Station

- 2,000 Watts of ultrasonic cleaning power
- All new, versatile size to meet a variety of parts cleaning needs
- Environmentally safe aqueous cleaning
- Easy-to-operate controls for time, temperature and cleaning cycle automation
- Stainless steel tank construction
- Dual filter system
- Oil removing surface sparger
- Optional on-board task light
- Heavy-duty locking casters
- High velocity ultrasonics, metallurgically attached transducers
- Ultrasonic frequency sweep to enhance cleaning performance



P/N	Description	Included Accesories:
25.00.001-110 <sup>1)</sup>	Complete ultrasonic cleaning station, 110 V <i>Contains:</i> <ul style="list-style-type: none"> <li>• Ultrasonic cleaner</li> <li>• Soak tank</li> <li>• Backwash cabinet</li> <li>• Drying cabinet</li> </ul>	<ul style="list-style-type: none"> <li>• 13 Watt high intensity inspection light</li> <li>• Roll polytubing</li> <li>• Bag sealer</li> <li>• Soak solution, two barrels</li> <li>• Detergent for ultrasonic, two 20 liter pails</li> <li>• Syphon pump for transfer of soak solution</li> <li>• Cleaning video and cleaning procedures</li> <li>• Layout drawing for setting up station</li> <li>• Cleaning detergent for two years</li> </ul>
25.00.001-220 <sup>1)</sup>	Complete ultrasonic cleaning station, 220 V <i>Contains:</i> <ul style="list-style-type: none"> <li>• Ultrasonic cleaner</li> <li>• Soak tank</li> <li>• Backwash cabinet</li> <li>• Drying cabinet</li> </ul>	<ul style="list-style-type: none"> <li>• 13 Watt high intensity inspection light</li> <li>• Roll polytubing</li> <li>• Bag sealer</li> <li>• Soak solution, two barrels</li> <li>• Detergent for ultrasonic, two 20 liter pails</li> <li>• Syphon pump for transfer of soak solution</li> <li>• Cleaning video and cleaning procedures</li> <li>• Layout drawing for setting up station</li> <li>• Cleaning detergent for two years</li> </ul>

<sup>1)</sup> Does not include high pressure washer. Customer preference; 2000 PSI required.

# Gas Engine Accessories



## Subcomponents



### Soak Tank

- Durable powder coated finish
- Inside tank dimensions 48 in. x 20 in. x 16 in.
- 1,500 Watt screw in heat element with built in thermostat
- 110 Volt power requirements
- Castor wheels for easy movement of unit
- Hinged lid
- Recirculation pump with 30 minute timer
- Optional heated tank

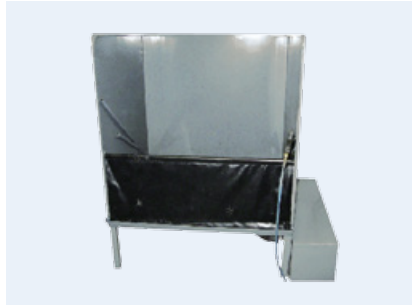

### Backwash Cabinet

- Powder coated finish
- Slotted subfloor parts rack
- Water backsplash curtain
- Adjustable parts rack
- Solids sediment waste water tank – 3 stage
- High pressure washer not included



### Drying Cabinet

- 4,800 Watt – 16000 BTU heating unit 210 V
- Durable powder coated finish
- Inside cabinet dimensions 48 in. x 30 in. x 24 in.
- 30 minute timer
- Hinged door with latch closures

Further Ultrasonic Cleaning Models and Accessories are available on request.



### Ultrasonic Cleaning Station Console Style Unit

- Inside tank dimensions 48 in. x 16 in. x 16 in.
- Electric heater, thermostatically controlled, 4,000 watts
- Ultrasonics – 40 KHz, 3,000 watts with pulse and sweep
- Transducers mounted on one side wall of tank
- Mechanical timer (1-30 minutes)
- Stainless steel lift cover
- Power requirements 240 V, 10, 50/60 Hz, 8 KVA



### Ultrasonic Cleaning Station Cabinet Model

- Inside tank dimensions 48 in. x 16 in. x 16 in.
- 25 KHz
- Variable power controls
- Built-in heater
- “Neptune“ Generator with pulse and sweep
- All stainless 316L cabinet construction
- Stainless lift off cover
- Heavy duty castors
- Recessed controls
- Recessed tank drain
- Available in 110 or 220 volt
- 2 year warranty on all components



### Cleaning Vessel

- Filtration of the cleaning fluid to enable maximum cleaning efficiency and extend cleaning solution life
- Pump is 110 V
- Filter unit consists of a stainless steel P2 vessel with a 1/2 HP high-temperature pump, discharge and suction hose

■ Gas Engine Accessories

NOTES

---

---

---

---

---

---

---

---

---

---

---

---

---

---

---

---

---

---

---

---

---

---

---

---

---

---

---

# ■ Gas Engine Accessories



A series of 25 horizontal blue lines spanning the width of the page, providing a template for text entry.

# ■ Technical Service & Support

## Technical Training at MOTORTECH The Key to your Success!

Qualified personnel are the prerequisite for seamless and efficient operation of your equipment and engine. To a large extent they define the level of availability, reliability and lifespan of your systems. The newly built training center at our headquarters in Celle is designed to teach specialists the professional handling of MOTORTECH products. All trainings are based on a hands-on approach and have practical relevance.

MOTORTECH's current seminars offer know-how and realistic solutions for today's challenges for professionals in the gas engine industry.  
Pragmatic – prompt – competent!

The training system is structured modular. The particular modules complement each other and deal with the topic on a whole altogether. Trainings can also be offered on an individual basis in order to cover specific learning needs.

- **Module 1:** Introduction into gas engine technologies  
Introduction to the MOTORTECH product world
- **Module 2:** MIC ignition controllers with MOST technology,  
DetCon detonation control
- **Module 3:** VariFuel2 air/gas mixer, EmCon5 emission control,  
speed control with ITB throttle body series
- **Module 4:** ALL-IN-ONE Generator & CHP Control System – Beginners course
- **Module 5:** ALL-IN-ONE Generator & CHP Control System – Basics course
- **Module 6:** ALL-IN-ONE Generator & CHP Control System – Advanced users

More details about our training, participation conditions and all necessary registration forms are available for download at: [www.motortech.de](http://www.motortech.de).

The MOTORTECH training team is happy to be at your disposal for every special question you might have.

## There is hardly any place we would not be able to support your needs and back up our product with service

### Service Team

Take advantage of MOTORTECH's many years of technical expertise in maintenance, repair and service. Our team participates in an ongoing training program and is familiar with the technical and maintenance procedures of all commonly used systems. Our technicians will perform know-how repairs using the latest test instruments and tools, either at your company site or at our own workshops, even on products that we did not produce. Furthermore, to assure you with the best possible delivery anywhere in the world, MOTORTECH maintains an extensive inventory of parts and finished goods.



## Always At Your Site

Regardless of which part of the globe we need to travel to, we know that the stakes are high, and therefore we also outperform the others. That is because we want everything to run smoothly at your site, everywhere and at anytime. This is entirely in keeping with our motto: Let us drop everything and work on your problem!



## Consulting

MOTORTECH's customer-focused know-how can provide support and consultation for your new developments, project planning, and problem analyses. Moreover, we are ready to assist you with advice and service at anytime. Just give us a call! You can be sure that our team will find an optimal solution for your particular problem area.



## MOTInside – MOTORTECH Information Center

MOTInside – All MOTORTECH sales and product information at your hand and always up to date on your USB flash drive.

MOTInside MOTORTECH Information Center provides you with all current MOTORTECH sales, service and product information on a USB flash drive. This information can be accessed via the software „MOTInside”, pre-installed on the flash drive, without having an internet connection.

### Contains:

- Operating manuals
- Configuration software
- Datasheets and specification sheets
- Catalogues and brochures
- Sales & Service Bulletins

The document database on the USB flash drive can be updated regularly each time the flash drive has access to the internet via the computer it is plugged in.

MOTInside – Your perfect companion for selling MOTORTECH products.

### Ordering Information

P/N	Description
01.01.001	MOTInside – MOTORTECH Information Center

More information about MOTInside is available at: [www.motortech.de/motinsideen.html](http://www.motortech.de/motinsideen.html)

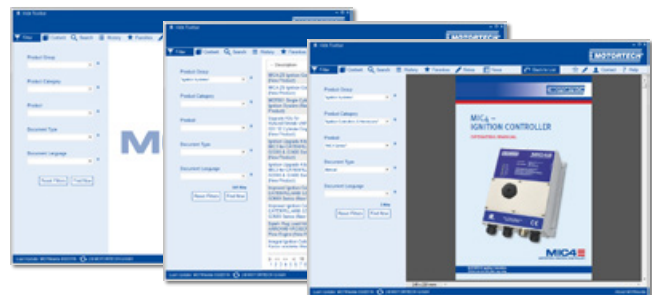



# Index

P/N	Page	P/N	Page	P/N	Page
0012E002200.....	34, 88	02.85.995-2 .....	85	06.00.525 .....	113
0012E006500.....	34, 88	02.85.996 .....	85	06.00.530 .....	113
01.01.001 .....	207	02.85.996-2 .....	85	06.01.040-L.....	66
01.56.001 .....	183	02.85.997 .....	85	06.01.041-L.....	66
1R-0716 .....	201	02.85.997-2 .....	85	06.01.042-L.....	66
1R-0726 .....	201	02.85.1004-100 .....	80	06.01.043-L.....	66
1W-4136.....	201	02.85.1006 .....	85	06.01.044-L.....	66
02-0004-174 .....	173	02.85.1007 .....	85	06.01.045-L.....	66
02.85.015-100 .....	136	02.85.1008 .....	85	06.01.046-L.....	66
02.85.016-100 .....	136	02.85.1012 .....	37, 80	06.01.047-L.....	66
02.85.017-100 .....	136	02.85.1012-100 .....	80	06.02.026-5 .....	173
02.85.757 .....	78	02.99.004-100 .....	79	06.02.026-15 .....	173
02.85.758 .....	78	2W-3742.....	26	06.02.026-25 .....	173
02.85.814-82 .....	78	2W-3744.....	26	06.02.026-50 .....	173
02.85.865-82 .....	78	2W-3747.....	29	06.02.027 .....	10, 13
02.85.870 .....	89, 90	2W-3748.....	26	06.02.028 .....	10, 13
02.85.881 .....	89, 90	03.90.050 .....	185	06.02.034-160 .....	10, 12, 15
02.85.914-82 .....	78	03.90.100 .....	185	06.02.035-160 .....	10, 12, 15
02.85.920 .....	78	03.90.140 .....	185	06.02.036-160 .....	10, 12, 15
02.85.920-100 .....	79	4W-2256.....	130	06.02.046-160 .....	11
02.85.924-100 .....	79	4W-4959.....	46	06.02.048-160 .....	20
02.85.925-100 .....	79	4W-5439.....	29	06.02.049-160 .....	20
02.85.965-82 .....	78	4W-5466.....	27	06.05.075 .....	10, 13, 16, 20, 99, 145
02.85.979 .....	85	4W-5468.....	27	06.05.076 .....	151
02.85.991 .....	85	06.00.508 .....	113	06.05.085 .....	23, 141, 147, 151
02.85.991-2 .....	85	06.00.510 .....	113	06.05.086-F.....	23, 141, 147
02.85.992 .....	85	06.00.511 .....	113	06.05.086-U .....	23, 141, 147
02.85.992-1 .....	85	06.00.513 .....	11, 113	06.05.088-F.....	151
02.85.992-2 .....	85	06.00.514 .....	11, 113	06.05.088-U .....	151
02.85.992-3 .....	85	06.00.515-6 .....	113	06.05.089-65 .....	173
02.85.993 .....	85	06.00.515-6/-8.....	11	06.05.092-65 .....	173
02.85.993-2 .....	85	06.00.515-8 .....	113	06.05.185 .....	23, 147, 151
02.85.994 .....	85	06.00.516 .....	11, 113	06.05.186 .....	23
02.85.994-2 .....	85	06.00.517 .....	113	06.05.903-1 .....	116
02.85.995 .....	85	06.00.520 .....	113	06.05.904-1 .....	116

P/N	Page	P/N	Page	P/N	Page
06.20.025	55	06.20.323	54	06.30.111-60	65
06.20.025-1	55	06.20.400	55	06.30.112	168
06.20.026	55	06.20.401	55	06.30.162	173
06.20.026-1	55	06.20.402	55	06.30.163-15000	173
06.20.045-1	55	06.20.403	55	06.31.030-1	26
06.20.045-6	55	06.20.404	55	06.31.030-2	26
06.20.045-8	55	06.22.400-1	57	06.31.032-1	26
06.20.069-1	55	06.22.400-6	57	06.31.032-2	26
06.20.069-6	55	06.22.400-8	57	06.50.003	29, 97
06.20.069-12	55	06.23.001	57	06.50.007	29
06.20.070	55	06.23.004	57	06.50.034	38, 40
06.20.251	55	06.30.022	173	06.50.034-L-C	39
06.20.252	55	06.30.023	173	06.50.034-L-D	39
06.20.254	55	06.30.024	173	06.50.035	38, 40, 42
06.20.300	54	06.30.025	173	06.50.035-30-A	39
06.20.301	54	06.30.026	173	06.50.035-36-E	39
06.20.302	54	06.30.027	173	06.50.035-L-C	39
06.20.303	54	06.30.028	173	06.50.035-L-D	39
06.20.304	54	06.30.039	173	06.50.036	38, 40
06.20.305	54	06.30.040	173	06.50.036-L-C	39
06.20.306	54	06.30.041	173	06.50.036-L-D	39
06.20.307	54	06.30.042	173	06.50.053	29, 97
06.20.308	54	06.30.043	173	06.50.054	29, 97
06.20.309	54	06.30.044	173	06.50.055	25, 29, 97
06.20.310	54	06.30.045	189	06.50.059	32
06.20.311	54	06.30.053	173	06.50.060	29, 97
06.20.312	54	06.30.054	173	06.50.065	29, 97
06.20.313	54	06.30.055	173	06.50.100	28, 97
06.20.314	54	06.30.056	173	06.50.102	28, 97
06.20.316	54	06.30.060	173	06.50.103	29, 97
06.20.317	54	06.30.093	173	06.50.104	28, 97, 105, 106, 107
06.20.318	54	06.30.100	173	06.50.105	28, 97
06.20.319	54	06.30.101	173	06.50.111	31
06.20.321	54	06.30.102	173	06.50.112	28, 97, 107
06.20.322	54	06.30.110	170	06.50.113	28, 97

# Index

P/N	Page	P/N	Page	P/N	Page
06.50.141	30, 35, 89	06.60.023	50	06.80.116-180	37
06.50.142	30, 35, 89	06.60.027	50	06.80.116-180-100	80
06.50.143	30, 35, 89	06.60.040	50	06.80.126	37, 117
06.50.144	30, 35, 89	06.60.042	50	06.80.126-100	80
06.50.145	30, 35, 89	06.60.101	50	06.80.145-1	34, 88
06.50.146	30, 35, 89	06.60.102	50	06.80.145-2	34, 88
06.50.147	30, 35, 89	06.60.103	50	06.80.202	87
06.50.148	30, 35, 89	06.60.105	50	06.80.202-T	87
06.50.151	30, 35, 89	06.60.107	50	06.80.206	87
06.50.152	30, 35, 89	06.60.900	56	06.80.206-T	87
06.50.153	30, 35, 89	06.60.908	60	06.80.213	87
06.50.154	30, 35, 89	06.60.922	56	06.80.213-T	87
06.50.155	30, 35, 89	06.60.925	56	06.80.261	37, 80
06.50.156	30, 35, 89	06.60.926	60	06.80.261-100	79
06.50.157	30, 35, 89	06.70.192-5	112	06.80.279H	90
06.50.158	30, 35, 89	06.70.192-6	112	06.80.280H	90
06.50.159	30	06.71.001-L	53	06.80.309	87
06.50.160	30	06.71.002-L	53	06.80.309-T	87
06.50.161	31, 34, 88	06.71.007	53	06.80.310	87
06.50.162	31, 34, 88	06.75.103	60	06.80.310-T	87
06.50.164	31, 34, 88	06.77.006-72	26	06.80.315H	35, 90
06.50.165	31, 34, 88	06.77.006-96	26	06.80.319	87
06.50.170	31, 34, 88	06.80.005	36	06.80.319H	87
06.50.174	31, 34, 88	06.80.006	36	06.80.319-T	87
06.50.175	31, 34, 88	06.80.012-100	80	06.80.320	87
06.50.300	28, 97, 105, 106, 107	06.80.030	76	06.80.320H	87
06.50.301	28, 97	06.80.036	36	06.80.320-T	87
06.51.133	89, 90	06.80.037	36	06.80.321	42, 87
06.51.134	89, 90	06.80.091	37	06.80.321H	87
06.51.136	89, 90	06.80.091-100	79	06.80.321-T	42, 87
06.51.223	37	06.80.104	56, 116	06.80.330	87
06.51.248	73	06.80.108	37	06.80.330-T	87
06.60.020	50	06.80.108-100	80	06.80.335H-1	90
06.60.021	50	06.80.116	37, 117	06.80.340	87
06.60.022	50	06.80.116-100	80	06.80.340-T	87

P/N	Page	P/N	Page	P/N	Page
06.80.349-L.....	90	06.80.754 .....	35, 89, 90	06.84.053-100 .....	81
06.80.356H .....	88	06.80.754-2 .....	89, 90	06.84.059 .....	70, 71, 72, 73, 74, 81, 89, 90
06.80.360H .....	88	06.80.755-T.....	87	06.84.059-100 .....	81
06.80.376-10 .....	90	06.80.756-T.....	87	06.84.069 .....	48
06.80.376-L.....	90	06.80.1013-T.....	34, 88	06.84.077 .....	72, 81
06.80.381H .....	87	06.81.005 .....	72	06.84.077-100 .....	81
06.80.415H .....	35, 90	06.81.017 .....	74	06.84.082 .....	36
06.80.417H .....	35, 90	06.81.051 .....	89, 90	06.84.083 .....	36
06.80.418H .....	35, 90	06.81.071 .....	74	06.84.116 .....	48
06.80.419H .....	35, 90	06.81.084 .....	89, 90	06.84.117 .....	48
06.80.420H .....	35, 90	06.84.006 .....	36	06.84.121 .....	71, 74
06.80.459H .....	34, 88	06.84.008-100 .....	79	06.85.083-22 .....	70
06.80.460 .....	34, 88	06.84.009-100 .....	79	06.85.178-20 .....	71
06.80.461 .....	34, 88	06.84.010-100 .....	78	06.85.179-20 .....	14, 71
06.80.469-T.....	87	06.84.021 .....	36	06.85.271 .....	71
06.80.471-T.....	87	06.84.024 .....	37	06.85.272 .....	71
06.80.480 .....	35, 90	06.84.024-100 .....	78	06.85.281 .....	72
06.80.481 .....	90	06.84.025 .....	37	06.85.306-18 .....	72
06.80.515H .....	35, 90	06.84.025-100 .....	78	06.85.310H-11 .....	14, 71
06.80.600 .....	34, 88	06.84.026 .....	48	06.85.312 .....	72
06.80.602 .....	34, 88	06.84.033 .....	70, 74, 81	06.85.320H-18 .....	71
06.80.741 .....	35, 89	06.84.033-100 .....	81	06.85.326-16 .....	72
06.80.741-2 .....	89	06.84.034 .....	74, 81	06.85.357-26 .....	72
06.80.742 .....	35, 89, 90	06.84.034-100 .....	81	06.85.379 .....	74
06.80.742-2 .....	89, 90	06.84.038 .....	74, 81	06.85.380 .....	74
06.80.743 .....	35, 89	06.84.038-100 .....	81	06.85.415H-16 .....	71
06.80.743-2 .....	89	06.84.040 .....	70, 71, 72, 73, 74, 81, 87, 89, 90	06.85.422-16 .....	72
06.80.744 .....	35, 89, 90	06.84.040-100 .....	81	06.85.423-16 .....	72
06.80.744-2 .....	89, 90	06.84.043-100 .....	78	06.85.429-14 .....	72
06.80.751 .....	35, 89	06.84.044 .....	70, 71, 72, 73, 74, 81	06.85.479 .....	71
06.80.751-2 .....	89	06.84.044-100 .....	81	06.85.487-18 .....	70
06.80.752 .....	35, 89, 90	06.84.047-100 .....	81	06.85.505-18 .....	70
06.80.752-2 .....	89, 90	06.84.048-100 .....	81	06.85.514-16 .....	74
06.80.753 .....	35, 89	06.84.049-100 .....	81	06.85.528-14 .....	70
06.80.753-2 .....	89				

# Index

P/N	Page	P/N	Page	P/N	Page
06.85.577H-16 .....	70	06.85.873-18 .....	70	06.85.1030-16 .....	71
06.85.580H-18 .....	71	06.85.894-18 .....	72	06.85.1031-16 .....	71, 105, 106
06.85.586-14 .....	70	06.85.903-22 .....	74	06.85.1037-16 .....	70, 105
06.85.594-22 .....	70	06.85.908-22 .....	70	06.85.1038-20 .....	71, 106
06.85.594-L.....	73	06.85.908-22-0 .....	70	06.85.1042-18 .....	71, 107
06.85.649-16 .....	72	06.85.909-24 .....	70	06.85.1044-27 .....	74
06.85.667-26 .....	72	06.85.910-18 .....	70	06.85.1046-16 .....	74
06.85.670-16 .....	70	06.85.912-24 .....	72	06.85.1047-24 .....	70
06.85.672H-22 .....	72	06.85.913-30 .....	72	06.85.1049-16 .....	71
06.85.678-24 .....	72	06.85.926-20 .....	70	06.85.1050-18 .....	71
06.85.683-18 .....	70	06.85.929-20 .....	71, 106	06.85.1052-24 .....	71
06.85.687-L.....	73	06.85.939-18 .....	73	06.85.1054-18 .....	70, 73
06.85.688-16 .....	72	06.85.945-16 .....	72	06.85.1058-18 .....	71
06.85.689-24 .....	74	06.85.949-10 .....	74	06.85.1062-16 .....	74
06.85.690-24 .....	74	06.85.952 .....	74	06.85.1063-14 .....	72
06.85.695-24 .....	74	06.85.954-16 .....	70	06.85.1068-18 .....	70
06.85.697-20 .....	74	06.85.954-L.....	73	06.86.001-100 .....	80
06.85.698-30 .....	74	06.85.957-22 .....	70	06.86.002-100 .....	80
06.85.699-16 .....	72	06.85.958-16 .....	70	06.86.003-100 .....	80
06.85.705-16 .....	72	06.85.959-18 .....	71, 107	06.86.005-100 .....	80
06.85.709H-18 .....	70	06.85.964-20 .....	74	06.88.003-L/-K.....	73
06.85.714-24 .....	72	06.85.966-35 .....	70	06.88.009-16 .....	73
06.85.714-L.....	73	06.85.988-18 .....	70	06.88.010-16 .....	73
06.85.717H-24 .....	70	06.85.989-18 .....	71	06.88.015-48 .....	74
06.85.719-16 .....	74	06.85.993-24 .....	72	06.90.099-100 .....	110
06.85.720-18 .....	72	06.85.998-20 .....	71	06.90.099-105 .....	110
06.85.723-24 .....	72	06.85.999-14 .....	72	06.90.100 .....	110, 111
06.85.739-16 .....	72	06.85.1000-14 .....	72	06.90.104-100 .....	115
06.85.751-18 .....	70, 73	06.85.1005-24 .....	71	06.90.104-200 .....	115
06.85.773-15 .....	74	06.85.1006 .....	74	06.90.104-300 .....	115
06.85.835-18 .....	70	06.85.1013-12 .....	70	06.90.104-400 .....	115
06.85.836H-16 .....	71, 105, 106	06.85.1014-12 .....	70	06.90.104-600 .....	115
06.85.839H-16 .....	70, 105	06.85.1019-16 .....	70, 73	06.90.105 .....	110, 111
06.85.860-16 .....	74	06.85.1020-24 .....	70	06.90.264 .....	37
06.85.864-26 .....	70	06.85.1023-18 .....	71, 107	06.95.058 .....	60

P/N	Page	P/N	Page	P/N	Page
06.98.005-110	111	07.70.003	113	07.98.118-34	135
06.98.005-220	111	07.70.004	113	07.98.118-34-BEX6	135
06.98.011	117	07.70.005	113	07.98.118-34-BEX12	135
06.98.013	117	07.70.006	113	07.98.120-14	133
06.98.017	117	07.70.009	113	07.98.120-18	133
06.98.019	117	07.70.010	113	07.98.120-78	133
06.98.043-10	116	07.70.011	113	07.98.121-14	133
06.98.043-30	116	07.70.012	113	07.98.121-18	133
06.98.046	117	07.70.013	113	07.98.121-78	133
06.98.047	117	07.70.014	113	07.98.122-A	133
06.98.048	117	07.70.015	113	07.98.122-B	133
06.98.050	117	07.98.022	135	07.98.122-C	133
06.98.051	117	07.98.023	135	07.98.122-D	133
06.98.054	112	07.98.024	135	07.98.122-E	133
06.98.054-1	112	07.98.025	135	07.98.122-F	133
06.98.054-2	112	07.98.026	135	07.98.131	133
06.98.054-3	112	07.98.026-1	135	07.98.178-58	135
06.98.054-4	112	07.98.034	133	07.98.178-58-BEX6	135
06.98.054-5	112	07.98.035	133	07.98.178-58-BEX12	135
06.98.054-6	112	07.98.036	133	07.98.178-78	135
06.98.054-7	112	07.98.037	133	07.98.178-78-BEX6	135
06.98.096	116	07.98.047	113	07.98.178-78-BEX12	135
06.98.100-200	115	07.98.059	133	07.98.214-34	135
06.98.109	117	07.98.063	134	07.98.718	136
06.98.130	114	07.98.065	134	07.99.016	73
06.99.200-1	97	07.98.113	133	07.99.018-L	134
06.99.200-2	97	07.98.114-12	135	07.99.019-L	134
06.99.200-3	97	07.98.114-12-BEX6	135	07.99.020-L	134
6I-0407	168	07.98.114-12-BEX12	135	07.99.021-L	134
7/8GZ9	123	07.98.114-34	135	07.99.022-1-L	134
7/8GZ11	123	07.98.114-34-BEX6	135	07.99.022-2-L	134
07.70.001	113	07.98.114-34-BEX12	135	07.99.022-3-36	134
07.70.002-1	113	07.98.118-12	135	07.99.022-3-L	134
07.70.002-2	113	07.98.118-12-BEX6	135	07.99.022-4-L	134
07.70.002-3	113	07.98.118-12-BEX12	135	07.99.022-5-L	134

# Index

P/N	Page	P/N	Page	P/N	Page
07.99.022-6-2 .....	134	09.02.2301-L.....	75	09.02.7000-L.....	76
07.99.022-6-6 .....	134	09.02.2310-L.....	75	09.02.7001-L.....	76
7E-1585.....	155	09.02.2311-L.....	75	09.02.7100-L.....	76
7E-1589.....	155	09.02.3000-L.....	75	09.02.7101-L.....	76
7W-4377.....	40	09.02.3010-L.....	76	09.02.7200-L.....	76
7W4377.....	38	09.02.3011-L.....	76	09.02.7201-L.....	76
09.02.1000-L.....	75	09.02.3100-L.....	76	09.02.7300-L.....	76
09.02.1001-L.....	75	09.02.3101-L.....	76	09.02.7301-L.....	76
09.02.1010-L.....	75	09.02.3110-L.....	76	09.03.1000-L.....	77
09.02.1011-L.....	75	09.02.3111-L.....	76	09.03.4000-L.....	77
09.02.1100-L.....	75	09.02.3200-L.....	76	09.04.1000-L.....	77
09.02.1101-L.....	75	09.02.3201-L.....	76	09.04.4000-L.....	77
09.02.1110-L.....	75	09.02.3210-L.....	76	09.05.1000-L.....	77
09.02.1111-L.....	75	09.02.3211-L.....	76	09.05.4000-L.....	77
09.02.1200-L.....	75	09.02.3300-L.....	76	09.06.1000-L.....	77
09.02.1201-L.....	75	09.02.3301-L.....	76	09.06.4000-L.....	77
09.02.1210-L.....	75	09.02.3310-L.....	76	09.07.1000-L.....	77
09.02.1211-L.....	75	09.02.3311-L.....	76	09.07.4000-L.....	77
09.02.1300-L.....	75	09.02.4000-L.....	76	09.08.1000-L.....	77
09.02.1301-L.....	75	09.02.4001-L.....	76	09.08.4000-L.....	77
09.02.1310-L.....	75	09.02.4100-L.....	76	09.09.1000-L.....	77
09.02.1311-L.....	75	09.02.4101-L.....	76	09.09.2000-L.....	77
09.02.2000-L.....	75	09.02.4110-L.....	76	09.09.4000-L.....	77
09.02.2001-L.....	75	09.02.4200-L.....	76	09.10.1000-L.....	77
09.02.2010-L.....	75	09.02.4201-L.....	76	09.10.2000-L.....	77
09.02.2011-L.....	75	09.02.4300-L.....	76	09.10.3000-L.....	77
09.02.2100-L.....	75	09.02.4301-L.....	76	09.10.4000-L.....	77
09.02.2101-L.....	75	09.02.5000-L.....	76	09.11.1000-L.....	77
09.02.2110-L.....	75	09.02.5001-L.....	76	09.11.2000-L.....	77
09.02.2111-L.....	75	09.02.5100-L.....	76	09.11.3000-L.....	77
09.02.2200-L.....	75	09.02.5101-L.....	76	09.11.4000-L.....	77
09.02.2201-L.....	75	09.02.5200-L.....	76	09.12.1000-L.....	77
09.02.2210-L.....	75	09.02.5201-L.....	76	09.12.2000-L.....	77
09.02.2211-L.....	75	09.02.5300-L.....	76	09.12.3000-L.....	77
09.02.2300-L.....	75	09.02.5301-L.....	76	09.12.4000-L.....	77



P/N	Page	P/N	Page	P/N	Page
09.13.1000-L.....	77	15.07.231 .....	10, 13, 16, 20, 99, 145	25.00.009-50-30 .....	199
09.13.2000-L.....	77	18GZ4-77 .....	121	25.00.009-50-30-HT .....	199
09.13.3000-L.....	77	18GZ5-77-2 .....	121, 123	25.00.009-50-HT .....	199
09.13.4000-L.....	77	18GZ6-77-2 .....	121, 123	25.00.018-50 .....	199
9Y-3985.....	130	18GZ7 .....	121	25.00.018-50-49 .....	199
10.362-1 .....	52	18GZ20 .....	121	25.00.018-50-49-HT .....	199
10-320790-1 .....	75, 77	18GZ22 .....	121, 123	25.00.018-50-HT .....	199
10-382040-1 .....	44, 75, 77	18GZ44 .....	133	25.00.109-25 .....	199
13.20.002 .....	173	19.60.002 .....	172	25.00.109-50 .....	199
13.20.003-295 .....	173	19.60.004 .....	171	25.00.118-25 .....	199
13.20.003-590 .....	173	19.60.007 .....	170	25.00.118-50 .....	199
13.20.004 .....	173	19.60.015 .....	171	25.00.209 .....	199
14-3CPU .....	121	19.60.022 .....	171	25.00.218 .....	199
14FR-4DIU.....	121	19.60.023 .....	171	25.00.222 .....	201
14FR-4DIU3.....	123	19.60.027 .....	170	25.00.226 .....	201
14FR-4DPUO .....	121	19.60.029 .....	170	25.00.228 .....	201
14GZ6-77-2 .....	74, 123	19.71.002 .....	172	25.00.229 .....	201
14GZ-GL.....	121	19.71.004-32 .....	171	25.00.231 .....	201
14GZ-LL-FR.....	121	19.71.004-50 .....	171	25.00.300-1-CA .....	201
14R-3CPU .....	121	19.71.004-100 .....	171	25.00.300-CA .....	201
14R-4ADP .....	121	19.71.013 .....	170	25.00.301-6-CA .....	201
14R-4CDP .....	121	19.71.015-2 .....	171	25.00.301-CA .....	201
14R-4CIU .....	121	19.71.015-3 .....	171	25.00.302-CA .....	201
14R-4CIU2 .....	121	19.71.015-15 .....	171	25.00.303-1-CA .....	201
14R-4DIU2 .....	121	19.71.015-30 .....	171	25.00.303-CA .....	201
14R-4DIU3 .....	121	22.80.009 .....	37, 80	25.00.310-4/-7/-14-WA .....	201
14R-5BIU .....	121	22.80.009-100 .....	79	25.00.310-4-WA .....	201
14R-5BPU .....	121	22.85.802 .....	79, 117	25.00.310-7-WA .....	201
14R-5DPU .....	121	22.85.802-100 .....	79	25.00.310-14-WA .....	201
15.02.226 .....	60	22.85.803 .....	79, 117	25.00.310-WA .....	201
15.02.326 .....	60	22.85.803-100 .....	79	25.00.311-4/-7-WA.....	201
15.02.426 .....	60	24.95.002 .....	56	25.00.311-4-WA .....	201
15.07.112 .....	99	25.00.001-110 .....	202	25.00.311-7-WA .....	201
15.07.134 .....	10, 13, 16, 20, 99, 145	25.00.001-220 .....	202	25.00.311-WA .....	201
15.07.221 .....	99	25.00.009-50 .....	199	25.00.312-1-WA .....	201

# Index

P/N	Page	P/N	Page	P/N	Page
25.00.312-WA .....	201	30.40.101-68 .....	155	30.42.140-75 .....	153
25.00.313-1-WA .....	201	30.40.101-68AT2-7.....	155	30.42.140-75-HT .....	153
25.00.313-WA .....	201	30.40.101-68-HT .....	155	30.42.140-80 .....	153
25.00.314-10-WA .....	201	30.40.140-75 .....	155	30.42.140-80-HT .....	153
25.00.314-WA .....	201	30.40.140-80 .....	155	30.42.140-85 .....	153
25.00.315-WA .....	201	30.40.140-85 .....	155	30.42.140-85-HT .....	153
25.00.316-WA .....	201	30.40.141-75 .....	155	30.42.150-100 .....	153
25.00.317-WA .....	201	30.40.141-75-HT .....	155	30.42.150-100-HT .....	153
25.00.318-WA .....	201	30.40.141-80 .....	155	30.42.200-100 .....	153
25.00.320-3/-4/-5/-7-WS .....	201	30.40.141-80-HT .....	155	30.42.200-100-HT .....	153
25.00.320-3-WS .....	201	30.40.141-85 .....	155	30.42.200-105 .....	153
25.00.320-4-WS .....	201	30.40.141-85-HT .....	155	30.42.200-105-HT .....	153
25.00.320-5-WS .....	201	30.40.141-94AT2-9.....	155	30.42.200-115 .....	153
25.00.320-7-WS .....	201	30.40.150-100 .....	155	30.42.200-115-HT .....	153
25.00.320-WS .....	201	30.40.151-100 .....	155	30.43.152-100 .....	157
25.00.330-1-AR .....	201	30.40.151-100-HT .....	155	30.45.100-50D .....	179
25.00.330-AR .....	201	30.40.161-106 .....	155	30.45.100-60D .....	179
25.00.335-EMD.....	201	30.40.200-100 .....	155	30.45.140-65D .....	179
28.10.014 .....	151	30.40.200-105 .....	155	30.45.140-80D .....	179
30.30.102 .....	181	30.40.200-115 .....	155	30.45.200-100D .....	179
30.30.103 .....	181	30.40.201-100 .....	155	30.45.200-120D .....	179
30.30.104 .....	181	30.40.201-100-HT .....	155	30.45.250-150D .....	179
30.30.106 .....	181	30.40.201-105 .....	155	30.45.301-190D .....	179
30.30.107 .....	181	30.40.201-105-HT .....	155	30.45.351-225D .....	179
30.30.108 .....	181	30.40.201-115 .....	155	31.01.365 .....	185
30.30.114 .....	181	30.40.201-115-HT .....	155	31.01.371 .....	185
30.30.116 .....	181	30.41.151-106-VHP-6.....	159	31.01.372 .....	185
30.30.118 .....	181	30.41.151-106-VHP-12 .....	159	31.01.377 .....	185
30.40.050-42 .....	155	30.41.152-100-HT .....	157	31.01.720-23.0-3 .....	179
30.40.051-42 .....	155	30.42.050-42 .....	153	31.01.720-27.5-3 .....	179
30.40.051-42-HT .....	155	30.42.050-42-HT .....	153	31.01.720-30.0-3 .....	179
30.40.100-60 .....	155	30.42.100-60 .....	153	31.01.720-32.5-3 .....	179
30.40.100-68 .....	155	30.42.100-60-HT .....	153	31.01.720-35.0-3 .....	179
30.40.101-60 .....	155	30.42.100-68 .....	153	31.01.720-37.5-3 .....	179
30.40.101-60-HT .....	155	30.42.100-68-HT .....	153	31.01.720-40.0-3 .....	179

P/N	Page	P/N	Page	P/N	Page
31.01.720-42.5-3	179	31.01.750	180, 185	31.01.879	185
31.01.720-45.0-3	179	31.01.751	180, 185	31.01.886	185
31.01.720-47.5-3	179	31.01.752	180, 185	31.01.942	153, 157, 181
31.01.720-50.0-3	179	31.01.753	180, 185	31.01.943	183
31.01.720-52.5-3	179	31.01.754	180, 185	31.01.948-100	183
31.01.720-55.0-3	179	31.01.755	180, 185	31.01.948-140	183
31.01.720-57.5-3	179	31.01.756	180, 185	31.01.948-200	183
31.01.720-60.0-3	179	31.01.757	180, 185	31.01.948-250	183
31.01.720-62.5-3	179	31.01.758	180, 185	31.01.948-300	183
31.01.720-65.0-3	179	31.01.759	180, 185	31.01.948-350	183
31.01.720-67.5-3	179	31.01.761	180, 185	31.01.949	183
31.01.720-70.0-3	179	31.01.762	180, 185	31.01.955	186
31.01.720-72.5-3	179	31.01.763	180, 185	31.01.959	183
31.01.720-75.0-3	179	31.01.764	180, 185	31.01.960	153, 157, 181, 186
31.01.720-77.5-3	179	31.01.765	180, 185	31.01.965	183
31.01.720-80.0-3	179	31.01.766	180, 185	37-4047	30
31.01.720-82.5-3	179	31.01.767	180, 185	43.00.002	140
31.01.720-85.0-3	179	31.01.768	180, 185	43.00.020	140
31.01.720-87.5-3	179	31.01.772	180, 185	43.00.020-04	140
31.01.720-90.0-3	179	31.01.773	180, 185	43.00.020-06	140
31.01.720-92.5-3	179	31.01.774	180, 185	43.00.020-08	140
31.01.720-95.0-3	179	31.01.775	180, 185	43.00.020-12	140
31.01.720-97.5-3	179	31.01.776	180, 185	43.00.020-16	140
31.01.720-100.0-3	179	31.01.777	180, 185	43.00.020-20	140
31.01.720-102.5-3	179	31.01.778	185	43.00.102	140
31.01.720-107.5-3	179	31.01.779	180, 185	43.00.120	140
31.01.720-110.0-3	179	31.01.780	180, 185	43.00.202	140
31.01.720-115.0-3	179	31.01.781	180, 185	43.00.220	140
31.01.720-120.0-3	179	31.01.809	185	43.00.421-12	104
31.01.720-125.0-3	180	31.01.828	185	43.20.001	140, 144
31.01.720-130.0-3	180	31.01.858	185	43.20.002	140
31.01.720-135.0-3	180	31.01.863	185	43.20.018	140
31.01.720-140.0-3	180	31.01.867	185	43.30.004-60	140
31.01.720-145.0-3	180	31.01.871	185	43.30.016-25	144
31.01.720-150.0-3	180	31.01.876	185	43.30.016-30	144

# Index

P/N	Page	P/N	Page	P/N	Page
43.30.016-40 .....	144	56.01.090-30 .....	150, 169	63.50.054 .....	163
44.01.000 .....	131	56.01.090-40 .....	150, 169	63.50.061 .....	162
44.01.005 .....	131	56.01.090-60 .....	150, 169	63.50.062 .....	162
44.01.006 .....	131	56.01.090-K .....	150, 169	63.50.064 .....	163
44.01.009 .....	131	56.01.091-25 .....	168	63.50.064-BTB.....	163
44.01.023 .....	131	56.01.092-28 .....	168	63.50.064-MCB .....	163
44.01.024 .....	131	56.01.094-23 .....	167	63.50.075 .....	163
44.01.025 .....	131	56.01.094-59 .....	167	63.50.082 .....	162
44.04.005 .....	56	56.01.098-34 .....	168	63.50.085 .....	162
44.99.011 .....	60, 116	56.01.180-10 .....	150, 169	63.50.088 .....	163
44.99.912 .....	33, 86, 87	56.01.180-20 .....	150, 169	63.50.092 .....	163
44.99.918 .....	116	56.01.180-25 .....	150, 169	63.50.093 .....	163
51.13105-6013 .....	157	56.01.180-30 .....	150, 169	63.50.096 .....	162
51.13105-6021 .....	157	56.01.180-40 .....	150, 169	63.50.097 .....	162
51.25411-6028 .....	168	56.01.180-60 .....	150, 169	63.50.101 .....	162
51.27420-0008 .....	172	56.01.180-K .....	150, 169	63.50.104 .....	162, 163
51.27421-0158 .....	168	56.02.016 .....	172	63.50.104-HSS.....	162
51.27421-0158-MOT .....	168	56.02.017 .....	172, 189	63.50.105 .....	162
51.90020-0381-M.....	140	63.02.011 .....	189	63.50.112 .....	163
51.90490-0022-M.....	140	63.02.013 .....	189	63.50.114 .....	157, 159
56.01.001 .....	172	63.02.017 .....	182	63.50.115 .....	162
56.01.002 .....	172	63.03.002-20 .....	146, 151	63.50.118 .....	163
56.01.004 .....	172, 189	63.03.012-20 .....	146, 151	63.50.120 .....	162
56.01.005-42 .....	169	63.04.002 .....	153	63.50.175 .....	164
56.01.005-53 .....	169	63.04.176 .....	164	63.60.001-50 .....	157
56.01.005-70 .....	169	63.50.002 .....	163	63.60.002-50 .....	157
56.01.005-81 .....	169	63.50.005 .....	163	64.40.038 .....	167
56.01.010 .....	172	63.50.006 .....	163	66.00.310-6/-12.....	113, 114
56.01.011 .....	172, 189	63.50.007 .....	163	66.00.350-6 .....	10
56.01.017 .....	172, 189	63.50.007-HSS.....	163	66.00.350-6/-12.....	113, 114
56.01.021 .....	172, 189	63.50.010-100 .....	163	66.00.350-12 .....	10
56.01.025 .....	172	63.50.010-230 .....	163	66.00.356-8 .....	11
56.01.090-10 .....	150, 169	63.50.010-xxx .....	163	66.00.357-12 .....	11
56.01.090-20 .....	150, 169	63.50.011 .....	163	66.00.358-8 .....	11
56.01.090-25 .....	150, 169	63.50.022 .....	163	66.00.359-12 .....	11

# Index



P/N	Page	P/N	Page	P/N	Page
66.00.400-8	12	66.60.021-300	52	75.00.587	106
66.00.400-16	12	66.60.023-450	52	75.00.588	106
66.00.400-/410-/440-8/-16	113	72-00-0024	25	75.00.589	106
66.00.410-8	12	72-00-0025	25	75.00.590	107
66.00.410-16	12	72-00-0026	25	75.00.591	107
66.00.424-8	12	72-00-0027	25	75.00.595	107
66.00.424-8/-16	113, 114	72-00-0028	25	75.00.596	107
66.00.424-16	12	72-70-0125	25	75.00.597	107
66.00.440-8	12	72-70-0235	25	75.00.598	107
66.00.440-16	12	75.00.433	107	75.00.601	105
66.00.540-20	15, 113	75.00.434	107	75.00.602	105
66.00.541-20	15, 113, 114	75.00.435	107	75.00.603	105
66.00.542-20	15, 113	75.00.436	107	75.00.604	105
66.00.645-24	20	75.00.501	105	75.00.605	106
66.00.646-24	20	75.00.502	105	75.00.606	105
66.00.647-24	20	75.00.503	105	75.00.607	106
66.00.851	15	75.00.504	105	75.00.608	106
66.60.001-125	50	75.00.505	106	75.00.609	106
66.60.001-175	50	75.00.506	105	75.00.610	107
66.60.001-250	50	75.00.507	106	75.00.611	107
66.60.001-400	50	75.00.508	106	75.00.651	105
66.60.001-600	50	75.00.509	106	75.00.652	105
66.60.002-125	50	75.00.510	107	75.00.653	105
66.60.002-175	50	75.00.511	107	75.00.654	105
66.60.002-250	50	75.00.536	101	75.00.655	106
66.60.002-450	50	75.00.537	101	75.00.656	105
66.60.002-600	50	75.00.538	101	75.00.657	106
66.60.003-60	50, 57, 105, 106	75.00.539	101	75.00.658	106
66.60.003-100	50, 106, 107	75.00.540	101	75.00.659	106
66.60.011-180	52	75.00.581	105	75.00.660	107
66.60.011-340	52	75.00.582	105	75.00.661	107
66.60.012-175	50	75.00.583	105	75.10.097	97, 144, 150
66.60.012-250	50	75.00.584	105	75.10.120	97, 144, 150
66.60.012-450	50	75.00.585	106	75.10.280	97, 144, 150
66.60.012-600	50	75.00.586	105	75.10.303	97, 144, 150

# Index

P/N	Page	P/N	Page	P/N	Page
75.10.404 .....	13	76.64.005 .....	29	81.00.302-01 .....	197
75.30.046 .....	168	76.64.302 .....	29	81.00.302-04 .....	197
75.30.131 .....	56	76.70.007 .....	151	81.00.303-01 .....	197
75.30.131-1 .....	56	77.41.117-L.....	145	81.00.303-04 .....	197
75.30.132 .....	56	77.41.317-L.....	145	81.00.310-01 .....	197
75.30.133 .....	56	77.42.317-L.....	151	81.00.310-04 .....	197
75.30.133-1 .....	56	77.42.327-L.....	151	81.00.311-01 .....	197
75.30.137 .....	57	77.49.006 .....	16	81.00.311-04 .....	197
75.30.143 .....	33	77.49.007-1 .....	16	81.00.312-01 .....	197
75.30.144 .....	33	77.49.007-5 .....	16	81.00.312-04 .....	197
75.30.146 .....	13	77.49.007-7 .....	16	81.00.313-01 .....	197
75.30.148-6 .....	159	77.49.007-10 .....	16	81.00.313-04 .....	197
75.30.148-12 .....	159	77.49.008 .....	16	81.00.510 .....	197
75.30.149-6 .....	159	77.49.029-1 .....	10, 13	81.00.511 .....	197
75.30.149-12 .....	159	77.49.029-5 .....	10, 13	92.00.646-24 .....	21
75.30.150-08 .....	14	77.49.029-7 .....	10, 13	92.02.001-160 .....	21
75.30.150-12 .....	14	77.49.029-10 .....	10, 13	92.02.002-160 .....	21
75.30.150-16 .....	14	77.75.066 .....	167	93.00.400-8 .....	12
75.41.001 .....	106	77.75.068-50 .....	167	93.00.400-16 .....	12
75.41.002 .....	106	77.75.120-12 .....	104	93.00.410-8 .....	12
75.41.003 .....	106	77.75.121-12 .....	104	93.00.410-16 .....	12
75.41.005 .....	105	80.01.210-2001 .....	197	93.00.542-20 .....	15
75.41.006 .....	105	80.01.210-2004 .....	197	93.05.075 .....	13, 16
75.41.008 .....	107	80.01.210-3001 .....	197	95.01.010-42-RC .....	63
75.41.010 .....	107	80.01.210-3004 .....	197	95.01.010-60-RC .....	63
75.41.011 .....	105	80.01.210-4001 .....	197	95.01.010-96-RC .....	63
75.41.013 .....	106	80.01.210-4004 .....	197	95.01.010-180-RC .....	63
75.41.014 .....	105	80.01.214 .....	197	95.01.010-L.....	63
75.41.021 .....	107	80.01.214-1104 .....	197	95.01.010-L-3.....	63
75.41.022 .....	107	80.01.214-1204 .....	197	95.01.011-L.....	65
75.41.023 .....	107	80.01.214-2104 .....	197	95.01.012-14 .....	65
75.41.025 .....	105	81.00.300-01 .....	197	95.01.013-30 .....	65
75.41.026 .....	106	81.00.300-04 .....	197	95.01.020-30 .....	42
75.41.027 .....	106	81.00.301-01 .....	197	95.01.020-42-RC .....	63
75.90.295-100 .....	136	81.00.301-04 .....	197	95.01.020-60-RC .....	63

P/N	Page	P/N	Page	P/N	Page
95.01.020-96-RC .....	63	95.01.132-L.....	64	95.08.040-6 .....	47
95.01.020-180-RC .....	63	95.01.133-L.....	64	95.08.050-11 .....	47
95.01.020-L.....	63	95.01.140-L.....	66	95.08.070 .....	45, 97
95.01.020-L-3.....	63	95.01.141-L.....	66	95.08.142-11 .....	47
95.01.021-L.....	63	95.01.142-L.....	66	95.08.143-6 .....	47
95.01.022-L.....	63	95.01.143-L.....	66	95.09.001 .....	44
95.01.023-L.....	63	95.01.144-L.....	66	95.09.002 .....	44
95.01.024-L.....	65	95.01.145-L.....	66	95.09.003 .....	44
95.01.025-L.....	65	95.01.146-L.....	66	95.09.005 .....	44, 45, 97
95.01.026-L.....	65	95.01.147-L.....	66	95.09.010 .....	46
95.01.030-L.....	64	95.06.010-L.....	64	95.09.011 .....	46
95.01.031-L.....	64	95.06.020-L.....	64	95.09.012-6 .....	46
95.01.032-L.....	64	95.06.030-L.....	64	95.09.012-12 .....	46
95.01.033-L.....	64	95.06.110-L.....	64	95.09.013-6 .....	47
95.01.040-L.....	66	95.06.120-L.....	64	95.09.022-6 .....	46
95.01.041-L.....	66	95.07.010-L.....	91	95.09.022-12 .....	46
95.01.042-L.....	66	95.07.011-L.....	91	95.09.023-6 .....	46
95.01.043-L.....	66	95.07.012-L.....	91	95.09.030 .....	46
95.01.044-L.....	66	95.07.013-L.....	91	95.09.031 .....	46
95.01.045-L.....	66	95.07.020-L.....	91	95.09.033-6 .....	46
95.01.046-L.....	66	95.07.021-L.....	91	95.09.040-6 .....	46
95.01.047-L.....	66	95.07.022-L.....	91	95.09.040-12 .....	46
95.01.107-24 .....	65	95.07.023-L.....	91	95.09.050-6 .....	47
95.01.110-L.....	63	95.07.024-L.....	91	95.09.051-6 .....	47
95.01.110-L-3.....	63	95.08.001 .....	44	95.09.053 .....	44, 45, 97
95.01.111-L.....	65	95.08.002 .....	44	95.09.054 .....	44, 45, 97
95.01.120-30 .....	42	95.08.003 .....	44, 45, 97	95.09.055 .....	44, 45, 97
95.01.120-L.....	63	95.08.005 .....	44	95.09.060-11 .....	47
95.01.120-L-3.....	63	95.08.010-6 .....	46	95.09.061-11 .....	47
95.01.121-L.....	63	95.08.010-12 .....	46	95.09.070 .....	45, 97
95.01.122-L.....	63	95.08.020-6 .....	47	95.09.073 .....	45, 97
95.01.123-L.....	63	95.08.022-6 .....	46	95.09.074 .....	45, 97
95.01.124-L.....	65	95.08.022-12 .....	46	95.09.075 .....	45, 97
95.01.130-L.....	64	95.08.030-6 .....	46	95.09.100 .....	38, 40
95.01.131-L.....	64	95.08.030-12 .....	46	95.09.122-11 .....	47



# Index

P/N	Page	P/N	Page	P/N	Page
95.09.123-6	47	95.40.214-L	15	95.75.106	102
95.09.133	38, 40	95.40.217-L	10, 13, 15	95.75.106-B	102
95.09.134	38, 40	95.40.235-L	15, 20	95.75.107	102
95.09.135	38, 40	95.40.314-L	97	95.75.107-B	102
95.09.142-11	47	95.60.010-L	53	95.75.108	102
95.09.143-6	47	95.60.020-L	53	95.75.108-B	102
95.09.150	40	95.60.030-L	53	95.75.120-12	104
95.09.150-L-C	41	95.60.040-L	53	95.75.121-12	104
95.09.150-L-D	41	95.60.050-400	53	95.75.339-B	103
95.09.153	40	95.70.001-125	51	95.75.340-B	103
95.09.154	40	95.70.001-175	51	95.80.020-L	84
95.09.154-L-C	41	95.70.001-250	51	95.80.030-L	84
95.09.154-L-D	41	95.70.001-400	51	95.85.020-L	84
95.09.155	40, 42	95.70.001-600	51	95.85.030-L	84
95.09.155-30-A	41	95.70.002-125	51	95.86.406-NAN	96
95.09.155-36-E	41	95.70.002-175	51	95.86.407-NAN	96
95.09.155-L-C	41	95.70.002-250	51	95.86.411-NAN	96
95.09.155-L-D	41	95.70.002-450	51	95.86.427-NDN	96
95.09.156-20-B	41	95.70.002-600	51	95.86.437-NAN	96
95.09.222-6	46	95.70.003-60	51	95.86.606-NAN	96
95.09.222-12	46	95.70.003-100	51	95.86.607-NAN	96
95.09.223-6	46	95.70.012-175	51	95.86.608-NAN	96
95.09.233-6	46	95.70.012-250	51	95.86.609-NAN	96
95.30.008-1	27	95.70.012-450	51	95.86.611-NAN	96
95.30.008-2	27	95.70.012-600	51	95.86.613-NAN	96
95.30.008-3	27	95.75.024-1	100	95.86.614-NAN	96
95.30.008-4	27	95.75.024-1-B	100	95.86.616-NAN	96
95.30.008-5	27	95.75.025-1	100	95.86.618-NAN	96
95.30.008-6	27	95.75.025-1-B	100	95.86.627-NDN	96
95.30.008-7	27	95.75.048	103	95.86.627-NFN	96
95.30.008-8	27	95.75.048-B	103	95.86.808-NAN	96
95.30.008-9	27	95.75.067-1	100	95.86.809-NAN	96
95.30.008-10	27	95.75.067-1-B	100	95.86.811-NAN	96
95.30.008-11	27	95.75.103	102	95.86.813-NAN	96
95.40.114-L	97	95.75.103-B	102	95.86.814-NAN	96

# Index



P/N	Page	P/N	Page	P/N	Page
95.86.814-NFN	96	163-6164,	11	264-5323	34, 88
95.86.815-NAN	96	165-1589	30, 35, 90	270A-8817	25
95.86.816-NAN	96	165-1590	30, 35, 90	283-5269	31
95.86.818-NAN	96	165-1591	30, 35, 90	283-5270	34, 88
95.87.340-NAN	96	165-1592	30, 35, 90	283-5271	34, 88
95.87.344-NAN-04	96	169-4295	88	290-7079	100
95.87.531-NAN-08	96	175-5341	168	291-5862	100
95.87.541-NGN-10	96	191-5007	102	308-1380	34, 88
95.87.544-NGN-06	96	191-5008	102	310-3180	31
95.87.631-NGN-08	96	191-9346	31	330-2-AI-46	25
95.87.631-NGN-10	96	193-468157	31, 34, 88	356-3701	30
95.87.633-NFN-22	96	196-5391	170	383-2989	168
95.87.637-NAN	96	198-2938	102	400A-8811	25
95.87.822-NGN-06	96	198-2941	102	400A-8813	25
95.90.020-L	83	199-9011	30	400A-8814	25
95.90.030-L	83	213-6308	102	407L	121
95.91.020-L	83	213-7443	30, 35, 90	407XL	121
95.91.030-L	83	213-7444	30, 35, 90	418-4861	30
95.99.200-1	97	215-2434	46	418-4862	30
95.99.200-2	97	219-9946	102	437-4047	30
95.99.200-2-X	97	232-6346	30, 35, 90	437-4049	30
107-2400	46	232-6347	30, 35, 90	437-4106	30
108-0615	30, 35, 90	232-6348	30, 35, 90	438-5682	31
122-8070	30, 35, 90	232-6349	30, 35, 90	451-00-042-00	155
123-4710	87	232-6350	30, 35, 90	452-00-068-00	155
123-8641	87	232-6351	31	453-00-085-01	155
124-0749	30, 35, 90	232-6352	30, 35, 90	454-00-115-00	155
129-8802	30, 35, 90	232-6353	30, 35, 90	600-00-111-00	52
131-3277	30, 35, 90	236-0484-DS	140	656-701-003	87
133-5078	88	241-9591	168	757	78
141-2494	170	251-2052	100	758-133	201
150-2050	34, 88	251-2053	100	807	121
152-0807	168	258-4893	31, 34, 88	827	121
163-6108	11, 113	259-2078	30, 35, 90	837/9,	31
163-6164	113	260D-8810	25	837/12	29

# Index

P/N	Page	P/N	Page	P/N	Page
837/13.....	29	7303.....	121	26510-04 .....	87
847.....	121	7305.....	121	26510-05 .....	87
1187.....	25	7306.....	121	26510-06 .....	87
1215 3964.....	29	7307.....	121	26510-07 .....	87
1215 3965.....	29	7308.....	121	26510-10 .....	87
1227 8370.....	14	7311.....	121	60615F.....	46
1229 3602.....	168	7313.....	121	60999G .....	130
1229 6754.....	168	7315.....	121	60999T.....	42
1229 8101 KM (TEM-ZS1).....	14	7321.....	121	69692B .....	26
1229 9387.....	168	7322.....	121	69694.....	29
1229 9487.....	168	8923-1061 .....	173	69694B .....	29
1229 9989.....	52	10000-06176 .....	31	69694D .....	46
1230 0136.....	14	21418.....	79	69694F.....	38
1232 0993 KZ (TEM-ZS3).....	14	21459.....	79	69694F,.....	40
1232 2279.....	168	21606.....	78	69694G .....	38, 42
1242 0290.....	14	25080-01 .....	87	69694G, .....	40
1242 0480.....	14	25080-02 .....	87	69703.....	26
1469-008 .....	32	25080-03 .....	87	69919.....	42
3076.....	70	25080-04 .....	87	69957.....	39
3400.7-21.07.02-03 .....	34, 88	25080-05 .....	87	69957A .....	39, 41
5419-100 .....	78	25080-06 .....	87	101181 .....	52
5419-150 .....	79	25080-07 .....	87	101181-MOT.....	52
5419-151 .....	78	25080-08 .....	87	118257 .....	29
5419-735 .....	87	25080-11 .....	87	167602B .....	201
5419-801 .....	87	25080-12 .....	87	168660B .....	201
5419-802 .....	87	26400-01 .....	87	168660H .....	201
5419-803 .....	87	26400-02 .....	87	169994B-DS .....	140
5419-804 .....	87	26400-03 .....	87	172607 .....	201
5419-805 .....	87	26400-04 .....	87	178622 .....	26
5419-806 .....	87	26400-05 .....	87	178803 .....	27
5419-807 .....	87	26400-07 .....	87	178804 .....	27
5419-808 .....	87	26400-10 .....	87	194929 .....	167
6910-314 .....	172	26510-01 .....	87	207927A .....	90
6995.....	41	26510-02 .....	87	208472B .....	201
7302.....	121	26510-03 .....	87	208472C .....	201

P/N	Page	P/N	Page	P/N	Page
208502C	27	393014-2	27	583018-60	63
208503K	42	393014-3	27	583018-96	63
209728	26	393014-4	27	583018-180	63
211288S	167	393014-5	27	591007	46
211357P	42, 87	393014-6	27	591008	46
211357U	42, 87	393014-7	27	591010	29, 36, 75, 76, 77
211797A	87	393014-8	27	591010-S	44, 45, 77
214036D	167	393014-9	27	591011A	46
214046	164	393014-10	27	591011B	46
260604	56	393014-11	27	591011C	46
260605	56	393018-1	26	591012	38, 40
269717B	26	393023-1	26	591014-1	50, 51
291001	29, 36, 75, 76, 77	393023-2	26	591014-2	50, 51
291001-S	44, 45, 77	486501	199	591014-4	50, 51
295962	169	489488	201	591014-6	50, 51
295962A	169	489489	201	591018	38, 40, 42
295962B	169	489490	201	591040	29
296064B	87	489491	201	593020-L	83, 84
296064C	87	489493	201	593022-L	63
296064D	87	489495	201	593024-L	65
296064F	87	489508	199	593025-L	65
296064H	87	489522	201	593026-L	65
304126	201	489625	199	593027-30	42
305315C	201	489626	199	593027-L	63
305351E	201	501061	29, 36, 75, 76, 77	593029-L	63
305805	55	501061-S	44, 45, 77	593030-L	83, 84
305805A	55	504137	85	593035-L	63
305805F	55	504205	85	593036-L	63
305805G	55	510480	85	593041-1	26
305805N	55	583017-42	63	593041-2	26
305805P	55	583017-60	63	593048-L	53
305805R	55	583017-60KT	65	593052-L	53
305948A-DS	140	583017-96	63	593054-L	53
383018-2	26	583017-180	63	593057-L	53
393014-1	27	583018-42	63	593068-1	65

# Index

P/N	Page	P/N	Page	P/N	Page
593068-2	65	790303-1	55	A204072A	159
593069-L	64	790314-1	55	A211357L	87
593120-L	91	790316-1	55	A211357N	87
593130-L	91	790318-1	55	A211357R	87
593140-L	91	791015-1	52	A211357T	87
691118-1	50, 51	791016-2	52	A211357V	87
691118-2	50, 51	791037-4	52	A211357X	87
691118-4	50, 51	791041-3	52	A211357Y	87
691118-6	50, 51	791050-1	50, 51	A211357Z	87
702930	65	791050-2	50, 51	A211797G	87
705165	65	791050-4	50, 51	A211797H	42, 87
720002	56	791050-6	50, 51	A211797J	87
740011	81	2881124	33	A211797K	87
740283	103	2881178	44, 45	A211797P	42, 87
740608A	11	3340063	34, 88	A211797R	42, 87
740609A	11	3341380	34, 88	A211797S	87
740746B	65	3394578	29	A296064C	87
740746D	65	3938860	81	A296064D	87
790021	54	3973945	81	A296064E	87
790022	54	4011615	33	A296064F	87
790104-1	54	8345482	201	A296064G	87
790105-1	54	263210167	34, 88	A296064H	87
790106-1	54	A260D-8810	25	A296064J	87
790108-1	54	A400A-8811	25	A296064K	87
790114-1	54	A400A-8813	25	A296064L	87
790115-1	54	A400A-8814	25	A296805	87
790116-1	54	A400A-8817	25	A296805A	87
790118-1	54	A-661	201	A740106C	170
790122-1	54	A718	136	A740106D	170
790144	54	A754-L	64	A740106E	170
790150	54	A755-L	83, 84	A740106E-MOT	170
790151	54	A755-L-2	83, 84	A740735	170
790165	54	A69694G	38, 40, 42	A740746	65
790169	54	A168368E	55	ALTOS-1	85
790302-1	55	A204072	159	ALTSS-2	85

P/N	Page	P/N	Page	P/N	Page
AT2-7	155	FB77WPCC	42, 43, 70, 71, 72,	L1863DP	121
AT2-9	155		73, 87, 121, 123	L1863IP	121, 123
AWH22-“L“	75	FM601	25	L2252IP	123
AWH42-“L“	75	FMOS-1	85	L2282IP	123
AWH62-“L“	76	GE3-1	121	LT2001-L	64
AWH72-“L“	76	GE3-5	70, 71, 72, 73, 74, 105,	LT2011-L	64
AWH81-“L“	75		106, 107, 121, 123	LT2100-L	64
AWH82-“L“	76	GE5-1	121	LT73002-L	63
B99	201	GI3-1	70, 72, 121	LT73012-L	63
B754-L	64	GI3-3	42, 43, 70, 71, 72, 87, 121	M82N	72
B2224	123	GI3-5	121, 123	M-260D-8810	25
B2324	123	GK3-1	121	M-270A-8817	25
B2424	123	GK3-5	70, 71, 72, 73, 74,	M-400A-8811	25
B4321	70, 71, 73, 74,		105, 106, 121, 123	M-400A-8813	25
	105, 106, 107, 123	GL3-1	121	M-400A-8814	25
B7224	123	GL3-3	14, 71, 121	M“L“1C	91
B7324	123	GL3-5	14, 71, 107, 121, 123	M“L“-2C	91
B7424	123	GN3-1	121	M“L“-2E	91
B8124	87, 123	GT3-1	72, 74, 87, 121, 123	M“L“-2S	91
B8324	14, 42, 43, 73, 87, 107, 123	HT1300-L	83, 84	MOT601	25
B8524	123	HT1400-L	83, 84	PB78WPC	121
BENDOS-1	85	HT2300-L	83, 84	PPT2477AA6	46
C754-L	64	HT2400-L	83, 84	PPT2477AA12	46
D14	72	ICPB412	130	PPT2477AB6	47
D14N	72, 74	ICPB432	130	PPT2477AD	44, 45, 75, 76, 77
D16	72	ICPB812	130	PPT2477ADL	44, 45, 77
D-199	79	ICPB832	130	PPT2477L	76
D211359G	166	J6C	74	PPT2477P	76
D211359G-MOT	166, 167	J8C	74	R407L	121
DL08220604	172	J1443DP	121	R407XL	121
DL08311001	170	J1463DP	121, 123	R717	123
DL08311003	170	KB77WPCC	121	R807LL	121
E204072	159	L1843B	121	RB75N	121
E204072A	159	L1843IP	121, 123	RB75PP	121
F204072A	159	L1863B	121	RB75WPCC	71, 123

# Index

P/N	Page	P/N	Page	P/N	Page
RB75WPCC-1	121	RSL2LA-“L“AIPS	75	ST-33XL	78
RB76N	121	RSL2LAL-“L“A	75	T-22	79
RB76PP	121	RSL2LAL-“L“AIPS	75	T-33	79
RB77CC	121	RSL2LB-“L“A	75	TCR-10WM	90
RB77WPCC	121	RSL2LB-“L“AIPS	75	TCRC-“L“	90
RB114-1	123	RSL2LBL-“L“A	75	TCR-“L“	90
RB212-1	123	RSL2LBL-“L“AIPS	75	U827	121
RB485-1	123	RSL2LC-“L“A	76	U847	121
RC78PYP	70, 71, 72, 74, 121, 123	RSL2LC-“L“AIPS	76	USL2A-“L“A	75
RC78PYP15	121	RSL2LCL-“L“A	76	USL2A-“L“AIPS	75
RC78WYP15	121	RSL2LCL-“L“AIPS	76	USL2AL-“L“A	75
RL15B	121	RSL2LE-“L“A	76	USL2AL-“L“AIPS	75
RL85G	121	RSL2LE-“L“AIPS	76	USL2B-“L“A	75
RM77N	72, 74, 87, 121, 123	RSL2LF-“L“A	76	USL2B-“L“AIPS	75
RM77PP	121, 123	RSL2LF-“L“AIPS	76	USL2BL-“L“A	75
RN79G	70, 71, 72, 73, 74, 121, 123	RSL2LG-“L“A	76	USL2BL-“L“AIPS	75
RSL2A-“L“A	75	RSL2-LG-“L“AIPS	76	USL2C-“L“A	75
RSL2A-“L“AIPS	75	RTB77WPCC	130	USL2C-“L“AIPS	76
RSL2AL-“L“A	75	RTL85G	130	USL2CL-“L“A	76
RSL2AL-“L“AIPS	75	RTM77N	130	USL2CL-“L“AIPS	76
RSL2B-“L“A	75	RTM77PP	130	USL2E-“L“A	76
RSL2B-“L“AIPS	75	RTN79G	130	USL2F-“L“A	76
RSL2BL-“L“A	75	RW77N	123	USL2F-“L“AIPS	76
RSL2BL-“L“AIPS	75	RW77PP	70, 123	USL2G-“L“A	76
RSL2C-“L“A	76	RW78N	123	USL2G-“L“AIPS	76
RSL2C-“L“AIPS	76	RW80N	70, 72, 74, 123	USL2LA-“L“A	75
RSL2CL-“L“A	76	RW80PP	70	USL2LA-“L“AIPS	75
RSL2CL-“L“AIPS	76	RW82P	72	USL2LAL-“L“A	75
RSL2E-“L“A	76	RW83F	74	USL2LAL-“L“AIPS	75
RSL2E-“L“AIPS	76	SC1K	85	USL2LB-“L“A	75
RSL2F-“L“A	76	SC2K	85	USL2LB-“L“AIPS	75
RSL2F-“L“AIPS	76	SFI-KIT	25	USL2LBL-“L“A	75
RSL2G-“L“A	76	SL2E-“L“AIPS	76	USL2LBL-“L“AIPS	75
RSL2G-“L“AIPS	76	SO-5	78	USL2LC-“L“AIPS	76
RSL2LA-“L“A	75	ST-22XL	78	USL2LCL-“L“A	76



# Index



P/N	Page	P/N	Page
USL2LCL-“L“AIPS .....	76	USLE78SPB-“L“A.....	77
USL2LE-“L“A .....	76	USLESB180-“L“A.....	77
USL2LE-“L“AIPS .....	76	USLESL90-“L“A .....	77
USL2LF-“L“A .....	76	W18.....	74, 123
USL2LF-“L“AIPS .....	76	W77N .....	123
USL2LG-“L“A.....	76	W80N .....	70
USL2LG-“L“AIPS.....	76	W54883.....	79
USLA14SPB-“L“A .....	77	Z00-17-001-00 .....	29
USLA18SPB-“L“A .....	77		
USLA18T22-“L“A.....	77		
USLA18T33-“L“A.....	77		
USLA35SPB-“L“A .....	77		
USLA36SPB-“L“A .....	77		
USLA45SPB-“L“A .....	77		
USLA51SPB-“L“A .....	77		
USLA78SPB-“L“A .....	77		
USLASB180-“L“A .....	77		
USLASL90-“L“A.....	77		
USLB18T22-“L“A.....	77		
USLB18T33-“L“A.....	77		
USLB78SPB-“L“A .....	77		
USLBSB180-“L“A .....	77		
USLSL90-“L“A.....	77		
USLC18T22-“L“A.....	77		
USLC18T33-“L“A.....	77		
USLCSB180-“L“A .....	77		
USLCSL90-“L“A.....	77		
USLE14SPB-“L“A.....	77		
USLE18SPB-“L“A.....	77		
USLE18T22-“L“A .....	77		
USLE18T33-“L“A .....	77		
USLE35SPB-“L“A.....	77		
USLE36SPB-“L“A.....	77		
USLE45SPB-“L“A.....	77		
USLE51SPB-“L“A.....	77		



**MOTORTECH GmbH**  
Hogrevestr. 21-23  
29223 Celle  
Germany  
Phone: +49 (5141) 93 99 0  
Fax: +49 (5141) 93 99 99  
[www.motortech.de](http://www.motortech.de)  
[sales@motortech.de](mailto:sales@motortech.de)

**MOTORTECH Americas, LLC**  
1400 Dealers Avenue, Suite A  
New Orleans, LA 70123  
USA  
Phone: +1 (504) 355 4212  
Fax: +1 (504) 355 4217  
[www.motortechamericas.com](http://www.motortechamericas.com)  
[info@motortechamericas.com](mailto:info@motortechamericas.com)

**MOTORTECH Shanghai Co. Ltd.**  
Room 1018 Enterprise Square,  
No. 228 Meiyuan Road,  
Zhabei District, 200070 Shanghai  
China  
Phone: +86 (21) 6380 7338  
[www.motortechshanghai.com](http://www.motortechshanghai.com)  
[info@motortechshanghai.com](mailto:info@motortechshanghai.com)



### MOTORTECH Newsletter

Always up-to-date to  
the latest news

**Subscribe now!**

*Scan QR-Code for subscription*